

**ARMY TM 9-2815-538-24&P
AIR FORCE TO 38G1-129-3**

**TECHNICAL MANUAL
FIELD AND SUSTAINMENT MAINTENANCE
MANUAL INCLUDING REPAIR PARTS AND
SPECIAL TOOLS LIST**

**FOR
YANMAR
DIESEL ENGINE
4TNV84T-DFM
4 CYLINDER 2.0 LITER**

NSN 2815-01-538-4237 (EIC: N/A)

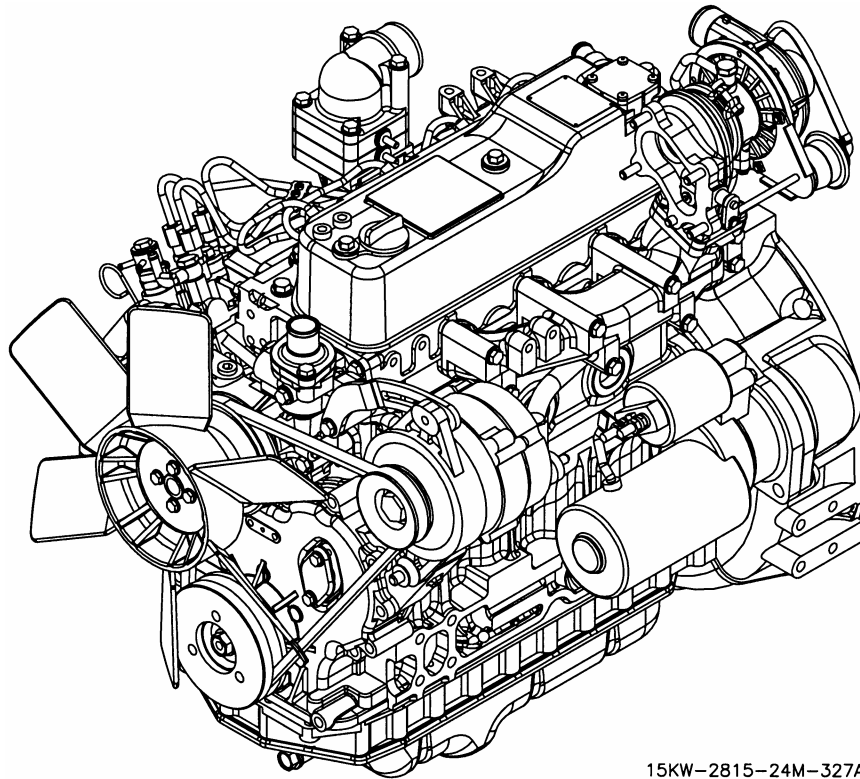

15KW-2815-24M-327A

DISTRIBUTION STATEMENT A – Approved for public release; distribution is unlimited.

**DEPARTMENTS OF THE ARMY AND THE AIR FORCE
15 JUNE 2008**

WARNING SUMMARY

This warning summary contains general safety warnings and hazardous materials warnings that must be understood and applied during operation and maintenance of this equipment. Failure to observe these precautions may result in serious injury or death to personnel. Also included are explanations of safety and hazardous material icons.

FIRST AID

For first aid, refer to FM 4-25.11.



5

SAFETY STEPS TO FOLLOW IF SOMEONE IS THE VICTIM OF ELECTRICAL SHOCK

1

DO NOT TRY TO PULL OR GRAB THE INDIVIDUAL

2

IF POSSIBLE, TURN OFF THE ELECTRICAL POWER

3

IF YOU CANNOT TURN OFF THE ELECTRICAL POWER, PULL, PUSH, OR LIFT THE PERSON TO SAFETY USING A DRY WOODEN POLE OR A DRY ROPE OR SOME OTHER INSULATING MATERIAL

4

SEND FOR HELP AS SOON AS POSSIBLE

5

AFTER THE INJURED PERSON IS FREE OF CONTACT WITH THE SOURCE OF ELECTRICAL SHOCK, MOVE THE PERSON A SHORT DISTANCE AWAY AND IMMEDIATELY START ARTIFICIAL RESUSCITATION

WARNING SUMMARY - Continued

SAFETY AND HAZARDOUS MATERIAL

This manual describes physical and chemical processes that may require the use of chemicals, solvents, paints, or other commercially available material. Users of the manual should obtain the material safety data sheets (Occupational Safety and Health Act (OSHA) Form 20 or equivalent) from the manufacturers or suppliers of materials to be used. Users must be completely familiar with manufacturer/supplier information and adhere to their procedures, recommendations, warnings, and cautions for safe use, handling, storage, and disposal of these materials.

EXPLANATION OF SAFETY WARNING ICONS



ELECTRICAL - electrical wire to hand with electricity symbol running through hand shows that shock hazard exists.



HOT AREA - hand over object radiating heat shows that part or area is hot and can burn.



HEAVY OBJECT - human figure stooping over heavy object shows physical injury potential from improper lifting technique or failure to share lifting task with other persons.



HEAVY PARTS - hand with heavy object on top shows that heavy parts can crush and harm if dropped.



HEAVY PARTS - foot with heavy object on top shows that heavy parts can crush and harm if dropped



MOVING PARTS - hand with figures caught between gears shows that the moving parts of the equipment present a danger to life or limb.



SHARP OBJECT - pointed object in hand shows that a sharp object presents a danger to limb.

WARNING SUMMARY - Continued

EXPLANATION OF SAFETY WARNING ICONS - Continued



EXPLOSION - flame and burst shows that material can explode if subjected to high temperatures, sources of ignition, or high pressure.



EYE PROTECTION - human figure with goggles shows that material can injure eyes.

GENERAL SAFETY WARNINGS DESCRIPTION

WARNINGS

Metal jewelry will conduct electricity. All jewelry can become entangled in unit components. Remove all jewelry when working on unit. Failure to comply may result in serious injury or death to personnel by electrocution.

WARNING

DO NOT wear loose clothing when performing checks, services, and maintenance. Failure to comply may result in serious injury or death to personnel.

WARNING

High voltage is produced when this unit is in operation. Make sure unit is completely shut down and free of any power source before attempting any repair or maintenance on unit. Failure to comply may result in serious injury or death to personnel.

WARNING

High voltage is produced when unit is in operation. Never attempt to start or maintain unit unless it is properly grounded. Failure to comply may result in serious injury or death to personnel.

WARNING

High voltage is produced when unit is in operation. Never attempt to connect or disconnect load cables while unit is running. Failure to comply may result in serious injury or death to personnel.

WARNING

A qualified technician must make power connections and perform all continuity checks. Power source may be a generator or commercial power. Failure to comply with this warning may result in serious injury or death to personnel.

WARNING SUMMARY - Continued

GENERAL SAFETY WARNINGS DESCRIPTION - Continued

WARNING

Direct Current (DC) voltages are present at unit electrical components even with unit shut down. Avoid shorting any positive with ground/negative. Failure to comply can cause injury to personnel and damage to equipment.

WARNING

Ensure power is off before performing troubleshooting procedures. Failure to comply may result in serious injury to personnel.

WARNING

Ensure that engine cannot be started while maintenance is being performed. Failure to comply may result in serious injury or death to personnel.

WARNING

When running, engine has hot metal surfaces that will burn flesh on contact. Shut down unit and allow engine to cool before performing checks, services, and maintenance. Wear gloves and additional protective clothing as required. Failure to comply may result in serious injury or death to personnel.

WARNING

When disconnecting or removing batteries, disconnect negative lead that connects directly to grounding stud first; disconnect negative end of interconnection cable next. When installing batteries, reverse connection sequence. Failure to comply may result in serious injury to personnel.

WARNING

Engine housing panels can get very hot. Allow panels to cool down before performing maintenance. Failure to comply may result in serious injury or death to personnel.

WARNING

Exhaust system can get very hot. Shut down unit and allow system to cool before performing checks, services, and maintenance. Failure to comply may result in severe burns and injury or death to personnel.

WARNING

The oil system operates at high temperature and pressure. Contact with hot oil can result in burns and scalding. Shut down unit and allow system to cool before performing checks, services, and maintenance. Wear heat resistant gloves and avoid contacting hot surfaces. Do not allow hot oil or components to contact skin or hands. Failure to comply may result in serious injury or death to personnel.

WARNING SUMMARY - Continued

GENERAL SAFETY WARNINGS DESCRIPTION - Continued

WARNING

Wear heat resistant gloves and avoid contacting hot metal surfaces with your hands after components have been heated. Wear additional protective clothing as required. Failure to comply may result in serious injury to personnel.

WARNING

Cooling system operates at high temperature and pressure. Contact with high pressure steam and/or liquids can cause burns and scalding. Shut down unit and allow system to cool before performing checks, services, and maintenance. Failure to comply may result in injury or death to personnel.

WARNING

In extreme cold weather, skin can stick to metal. Avoid contacting metal items with bare skin in extreme cold weather. Failure to comply may result in serious injury or death to personnel.

WARNING

Operating unit exposes personnel to a high noise level. Hearing protection must be worn when operating or working near unit when unit is running. Failure to comply may result in serious hearing damage to personnel.

WARNING

Many components require a two-person lift. Lifting heavy components can cause back strain. Ensure proper lifting techniques are used when lifting heavy components. Failure to comply may result in serious injury to personnel.

WARNING

Each battery weighs more than 70 pounds (32 kg) and requires a two-person lift. Lifting batteries can cause back strain. Ensure proper lifting techniques are used when lifting batteries. Failure to comply may result in serious injury to personnel.

WARNING

Unit is extremely heavy and requires an assistant and a lifting device (forklift, overhead lifting device) with sufficient capacity. Failure to comply may result in serious injury or death to personnel.

WARNING

Support components when removing attaching hardware or component may fall. Failure to comply may damage equipment and result in serious injury to personnel.

WARNING SUMMARY - Continued

GENERAL SAFETY WARNINGS DESCRIPTION - Continued

WARNING

Retaining rings and springs are under tension and can act as projectiles when being removed. Use eye protection when removing retaining rings or springs. Failure to comply may result in serious injury to personnel.

WARNING

Oil filter base and housing springs are under tension and can act as projectiles when being removed. Use eye protection when removing springs. Failure to comply may result in serious injury to personnel.

WARNING

Do not use engine starter to turn flywheel. Failure to comply may result in serious injury to personnel.

WARNING

Fan has sharp blades. Use caution and wear gloves when removing or installing belts. Failure to comply may result in serious injury to personnel.

WARNING SUMMARY - Continued

EXPLANATION OF HAZARDOUS MATERIALS ICONS



EYE PROTECTION - human figure with goggles shows that material can cause injury to eyes.



CHEMICAL - drops of liquid on hand shows that material can cause burns or irritation to human skin or tissue.



VAPOR - human figure in a cloud shows that material vapors present danger to life or possible death.



FIRE - flames show that material is flammable.



EXPLOSION - flame and burst shows that material can explode if subjected to high temperatures, sources of ignition, or high pressure.



RADIATOR - steam in face and body shows that escaping steam and hot water exist.

HAZARDOUS MATERIALS DESCRIPTION

WARNING

Batteries give off a flammable gas. Do not smoke or use open flame when performing maintenance. Failure to comply may result in damage to equipment and serious injury or death to personnel because of flames and explosion.

WARNING

Connection of any electrical equipment and disconnection of any electrical equipment may cause an explosion hazard. Do not connect or disconnect any electrical equipment in an explosive atmosphere. Failure to comply may result in serious injury or death to personnel.

WARNING SUMMARY - Continued

HAZARDOUS MATERIALS DESCRIPTION - Continued

WARNING

Diesel fuel is flammable and toxic to eyes, skin, and respiratory tract. Skin and eye protection are required when working in contact with diesel fuel. Avoid repeated or prolonged contact. Provide adequate ventilation. Personnel are to wash exposed skin and change chemical soaked clothing promptly if exposed to fuel. Failure to comply may result in serious injury or death to personnel.

WARNING

Cleaning solvent is flammable and toxic to eyes, skin, and respiratory tract. Skin and eye protection are required when working in contact with cleaning solvent. Avoid repeated or prolonged contact. Work in ventilated area only. Failure to comply may result in serious injury or death to personnel.

WARNING

Carbon removing compound is flammable and toxic to eyes, skin, and respiratory tract. Skin and eye protection are required when working in contact with carbon removing compound. Avoid repeated or prolonged contact. Work in ventilated area only. Failure to comply may result in serious injury or death to personnel.

WARNING

Fuels used in unit are flammable. Do not smoke or use open flames when performing maintenance. Failure to comply may cause flames and possible explosion. Failure to comply may result in damage to equipment and serious injury or death to personnel.

WARNING

Fuels used in unit are flammable. When filling fuel tank, maintain metal-to-metal contact between filler nozzle and fuel tank opening to eliminate static electrical discharge. Failure to comply may cause flames and possible explosion. Failure to comply may result in damage to equipment and serious injury or death to personnel.

WARNING

Hot exhaust gases can ignite flammable materials. Allow room for safe discharge of hot gases and sparks. Failure to comply may result in serious injury or death to personnel.

WARNING

Eye protection is required when working with compressed air. Compressed air can propel particles at high velocity and injure eyes. Do not exceed 15 psi pressure when using compressed air. Failure to comply may result in serious injury to personnel.

WARNING SUMMARY - Continued

HAZARDOUS MATERIALS DESCRIPTION - Continued

WARNING

Cleaning compound is toxic. Avoid prolonged breathing of vapors. Use in a ventilated area only. Failure to comply may result in serious injury to personnel.

WARNING

Avoid breathing fumes generated by soldering. Eye protection is required. Good general ventilation is normally adequate. Failure to comply may result in serious injury to personnel.

WARNING

Chemical Agent Resistant Coating (CARC) paint is a health hazard and is irritating to eyes, skin, and respiratory system. Wear protective eyewear, mask, and gloves when applying or removing CARC paint. Failure to comply may result in serious injury to personnel.

WARNING

Exhaust discharge contains deadly gases including carbon monoxide. Do not operate unit in an enclosed area unless exhaust discharge is properly vented outside. Failure to comply may result in serious injury or death to personnel.

Engine exhaust fumes contain deadly poisonous gases.

Severe exposure can cause death or permanent brain damage.

Exhaust gases are most dangerous in places with poor airflow. Best defense against exhaust gas poisoning is very good airflow.

To protect yourself and your partners, always obey the following rules:

- DO NOT run engine indoors unless you have VERY GOOD AIRFLOW.
- DO NOT idle engine for a long time unless there is VERY GOOD AIRFLOW.
- Be alert at all times. Check for smell of exhaust fumes.
- REMEMBER: Best defense against exhaust gas poisoning is VERY GOOD AIRFLOW.
- Exhaust gas poisoning causes dizziness, headache, loss of muscle control, sleepiness, coma, and death. If anyone shows signs of exhaust gas poisoning, get ALL PERSONNEL clear of unit. Make sure they have lots of fresh air. KEEP THEM WARM, CALM, AND INACTIVE. GET MEDICAL HELP. If anyone stops breathing, give artificial respiration. See FM 4-25.11 for first aid.

LIST OF EFFECTIVE PAGES/WORK PACKAGES

NOTE: Zero in the "Change No." column indicates an original page or work package.

Dates of issue for original manual is:

Original 15 June 2008

**TOTAL NUMBER OF PAGES FOR FRONT AND REAR MATTER IS 30 AND
TOTAL NUMBER OF WORK PACKAGES IS 64, CONSISTING OF THE
FOLLOWING:**

Page/WP No.	Change No	Page/WP No.	Change No
Front Cover	0	WP 0024 (4 pgs)	0
Inside Front Cover	0	WP 0025 (4 pgs)	0
Warning Summary (10 pgs)	0	WP 0026 (4 pgs)	0
i-iv	0	WP 0027 (4 pgs)	0
v blank	0	WP 0028 (8 pgs)	0
Chp 1 Title Page	0	WP 0029 (4 pgs)	0
Blank	0	WP 0030 (4 pgs)	0
Chp 1 Index Page	0	WP 0031 (2 pgs)	0
Blank	0	WP 0032 (4 pgs)	0
WP 0001 (6 pgs)	0	Chp 4 Title Page	0
WP 0002 (6 pgs)	0	Blank	0
WP 0003 (6 pgs)	0	Chp 4 Index Page	0
Chp 2 Title Page	0	Blank	0
Blank	0	WP 0033 (2 pgs)	0
Chp 2 Index Page	0	WP 0034 (4 pgs)	0
Blank	0	WP 0035 (4 pgs)	0
WP 0004 (2 pg)	0	WP 0036 (8 pgs)	0
WP 0005 (26 pgs)	0	WP 0037 (2 pgs)	0
Chp 3 Title Page	0	WP 0038 (2 pgs)	0
Blank	0	WP 0039 (2 pgs)	0
Chp 3 Index Page	0	WP 0040 (2 pgs)	0
Blank	0	WP 0041 (2 pgs)	0
WP 0006 (2 pgs)	0	WP 0042 (2 pgs)	0
WP 0007 (4 pgs)	0	WP 0043 (2 pgs)	0
WP 0008 (4 pgs)	0	WP 0044 (2 pgs)	0
WP 0009 (4 pgs)	0	WP 0045 (2 pgs)	0
WP 0010 (6 pgs)	0	WP 0046 (2 pgs)	0
WP 0011 (4 pgs)	0	WP 0047 (2 pgs)	0
WP 0012 (4 pgs)	0	WP 0048 (2 pgs)	0
WP 0013 (4 pgs)	0	WP 0049 (2 pgs)	0
WP 0014 (4 pgs)	0	WP 0050 (2 pgs)	0
WP 0015 (4 pgs)	0	WP 0051 (2 pgs)	0
WP 0016 (12 pgs)	0	WP 0052 (2 pgs)	0
WP 0017 (4 pgs)	0	WP 0053 (2 pgs)	0
WP 0018 (4 pgs)	0	WP 0054 (2 pgs)	0
WP 0019 (2 pgs)	0	WP 0055 (2 pgs)	0
WP 0020 (4 pgs)	0	WP 0056 (2 pgs)	0
WP 0021 (4 pgs)	0	WP 0057 (2 pgs)	0
WP 0022 (4 pgs)	0	WP 0058 (2 pgs)	0
WP 0023 (4 pgs)	0	WP 0059 (2 pgs)	0

Page/WP No.	Change No
WP 0060 (2 pgs)	0
WP 0061 (2 pgs)	0
WP 0062 (2 pgs)	0
WP 0063 (6 pgs)	0
WP 0064 (2 pgs)	0
INDEX-1 – INDEX-9	0
INDEX-10 blank	0
Inside Back Cover	0
Back Cover	0

HEADQUARTERS
DEPARTMENTS OF THE ARMY AND THE AIR FORCE
WASHINGTON, DC, 15 JUNE 2008

TECHNICAL MANUAL

**FIELD AND SUSTAINMENT MAINTENANCE MANUAL
INCLUDING REPAIR PARTS AND SPECIAL TOOLS LIST**

FOR

**YANMAR
DIESEL ENGINE
4TNV84T-DEM
4 CYLINDER 2.0 LITER**

(NSN 2815-01-538-4257) (EIC: N/A)

REPORTING ERRORS AND RECOMMENDING IMPROVEMENTS

You can help improve this manual. If you find any mistakes or if you know of a way to improve the procedures, please let us know. Reports, as applicable by the requiring Service, should be submitted as follows:

- (a) (A) Army - Mail your letter or DA Form 2028 (Recommended Changes to Publications and Blank Forms) located in the back of this manual, directly to: Commander, U.S. Army CECOM Life Cycle Management Command (LCMC) and Fort Monmouth, ATTN: AMSEL-LC-LEO-E-ED, Fort Monmouth, NJ 07703-5006. You may also send in your recommended changes via electronic mail or by fax. Our fax number is 732-532-1556, DSN 992-1556. Our e-mail address is MONM-AMSELLEOPUBSCHG@conus.army.mil. Our online web address for entering and submitting DA Form 2028s is <http://edm.monmouth.army.mil/pubs/2028.html>.
- (b) (F) Air Force - By Air Force AFTO Form 22 (Technical Manual (TM) Change Recommendation and Reply) in accordance with paragraph 6-5, Section VI, TO 00-5-1 directly to prime ALC/MST.

A reply will be furnished to you.

CURRENT AS OF 15 JUNE 2008

DISTRIBUTION STATEMENT A – Approved for public release; distribution is unlimited.

TABLE OF CONTENTS

WP Sequence No.

WARNING SUMMARY

HOW TO USE THIS MANUAL

CHAPTER 1 - INTRODUCTORY INFORMATION WITH THEORY OF OPERATION FOR DIESEL ENGINE

General Information	0001 00
Equipment Description and Data	0002 00
Theory of Operation	0003 00

CHAPTER 2 - TROUBLESHOOTING PROCEDURES FOR DIESEL ENGINE

Troubleshooting Index.....	0004 00
Troubleshooting Procedures.....	0005 00

CHAPTER 3 - MAINTENANCE INSTRUCTIONS FOR DIESEL ENGINE

Service Upon Receipt	0006 00
PMCS Introduction.....	0007 00
PMCS, Including Lubrication Instructions	0008 00
General Maintenance.....	0009 00
Battery Charging Alternator (24 Vdc).....	0010 00
Fan, V-Pulley, and V-Belt.....	0011 00
Water Pump Assembly.....	0012 00
Thermostat, Cover, and Temperature Switch	0013 00
Gear Case Assembly	0014 00
Idle Gear Assembly.....	0015 00
Fuel Injection Pump Assembly.....	0016 00
Fuel Filter and Fuel Hoses.....	0017 00
Oil Cooler Assembly and Oil Pressure Switch	0018 00
Starter Motor Assembly.....	0019 00
Fuel Injection Lines and Return Hose.....	0020 00
Valve Cover Assembly.....	0021 00
Fuel Injectors.....	0022 00
Compression Test.....	0023 00
Cylinder Head Assembly.....	0024 00
Valve Lash Adjustment	0025 00
Intake Manifold, Air Inlet Hose, and Air Heaters	0026 00
Turbocharger Oil Lines.....	0027 00
Turbocharger Assembly and Exhaust Manifold	0028 00
Crankcase Assembly and Dipstick.....	0029 00
Flywheel Assembly and Flywheel Housing.....	0030 00
Preparation for Storage or Shipment	0031 00
Torque Limits	0032 00

CHAPTER 4 - SUPPORTING INFORMATION FOR DIESEL ENGINE

References.....	0033 00
Maintenance Allocation Chart (MAC) Introduction	0034 00
Maintenance Allocation Chart (MAC)	0035 00
Repair Parts and Special Tools List Introduction.....	0036 00
Turbocharged Diesel Engine Repair Parts List	0037 00

TABLE OF CONTENTS - Continued

WP Sequence No.

CHAPTER 4 - SUPPORTING INFORMATION FOR DIESEL ENGINE - Continued

Cylinder Block Assembly Repair Parts List	0038 00
Rocker Arm Shaft Assembly Repair Parts List	0039 00
Cylinder Head Assembly Repair Parts List.....	0040 00
Valve Cover Assembly Repair Parts List.....	0041 00
Connecting Rod and Piston Assembly Repair Parts List	0042 00
Camshaft, Driving Gear, and Idle Gear Assemblies Repair Parts List.....	0043 00
Flywheel Assembly Repair Parts List	0044 00
Crankshaft Assembly Repair Parts List	0045 00
Gear Case Assembly Repair Parts List	0046 00
Cooling System Repair Parts List	0047 00
Fan Assembly Repair Parts List	0048 00
Fuel System Repair Parts List	0049 00
Fuel Injection Valve System Repair Parts List.....	0050 00
Fuel Injection Assembly Repair Parts List.....	0051 00
Oil Filter and Oil Cooler Repair Parts List.....	0052 00
Oil Bypass Valve Repair Parts List.....	0053 00
Oil Pump Assembly Repair Parts List.....	0054 00
Crankcase Assembly Repair Parts List	0055 00
Intake Manifold Repair Parts List.....	0056 00
Turbocharger Assembly Repair Parts List.....	0057 00
Starter Motor Assembly Repair Parts List	0058 00
Generator Repair Parts List.....	0059 00
Special Tools List.....	0060 00
Bulk Material List	0061 00
National Stock Number Index	0062 00
Part Number Index.....	0063 00
Expendable and Durable Items List.....	0064 00
INDEX	Index-1

HOW TO USE THIS MANUAL

This manual contains maintenance instructions for the Diesel Engine, 4TNV84T-DFM.

The table of contents will help you understand the organization of the manual and will direct you to the major sections. More detailed segments, such as specific maintenance instructions, can be located in the index at the end of the manual.

The References work package (WP 0033 00) provides a listing of other related manuals.

The Maintenance Allocation Chart (MAC) work package (WP 0035 00) provides tools and test equipment to perform maintenance.

The Expendable and Durable Items List work package (WP 0064 00) provides supplies to perform maintenance.

The Repair Parts and Special Tools List (RPSTL) work packages (WP 0036 00 thru WP 0063 00) list and authorize spares, repair parts, and special tools required for performance of maintenance.

While performing the procedures in this manual, you may find that you are able to make suggestions that will improve the manual. At the back of this manual, you will find copies of DA Form 2028 which invite you to submit your suggestions.

HOW TO USE THIS MANUAL - Continued

Read the INITIAL SETUP section carefully before you start any maintenance procedure. Get the tools and supplies listed and the personnel needed.

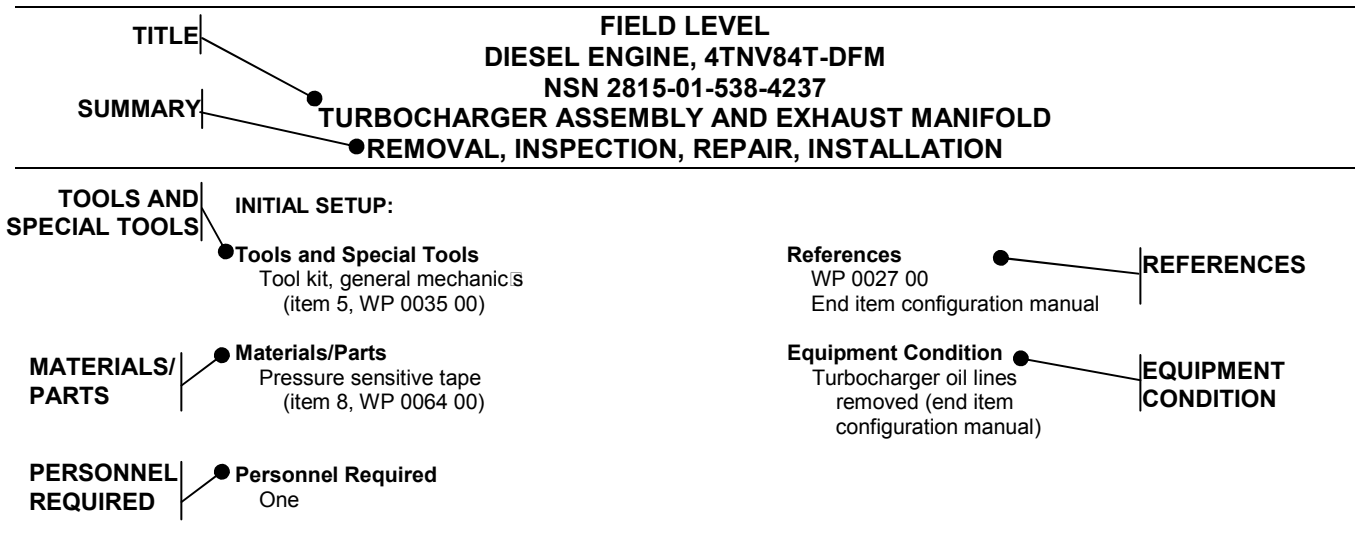

LEGEND:

- | | |
|--------------------------------|--|
| TITLE | The name of the procedure. |
| SUMMARY | A listing of the general actions to be performed. |
| TOOLS AND SPECIAL TOOLS | The tools and equipment needed to do the procedures. |
| MATERIALS/PARTS | The supplies and parts needed to do the procedures. |
| PERSONNEL REQUIRED | The personnel needed to do the procedures. |
| REFERENCES | Other work packages, manuals, and publications needed to do the procedure. |
| EQUIPMENT CONDITION | The special condition(s) to be performed before starting the procedure. |

CHAPTER 1
INTRODUCTORY INFORMATION WITH THEORY OF OPERATION
FOR
DIESEL ENGINE

CHAPTER 1

INTRODUCTORY INFORMATION WITH THEORY OF OPERATION FOR DIESEL ENGINE

WORK PACKAGE INDEX

<u>Title</u>	<u>WP Sequence No.</u>
GENERAL INFORMATION	0001 00
EQUIPMENT DESCRIPTION AND DATA.....	0002 00
THEORY OF OPERATION.....	0003 00

**FIELD LEVEL
DIESEL ENGINE, 4TNV84T-DFM
NSN 2815-01-538-4237
GENERAL INFORMATION**

SCOPE

This Technical Manual (TM) contains description, checks and adjustments, theory of operation, troubleshooting, and corrective maintenance for the Yanmar Diesel Engine, 4TNV84T-DFM.

Type of Manual: Field Level Maintenance with Field and Sustainment Level Repair Parts and Special Tools List.

Model Number and Equipment Name: Diesel Engine, 4TNV84T.

Purpose of Equipment: The diesel engine provides primary power for the 15 kW Tactical Quiet (TQ) Generator sets MEP-804B and MEP-814B and other military applications, offering the mobility and operational characteristics demanded by modern armed forces. Operational characteristics include the ability to operate at all possible humidity levels, at ambient temperature levels from -25°F to +120°F (-32°C to +49°C) and at altitudes up to 10,000 feet (3,048m).

CONSOLIDATED INDEX OF ARMY PUBLICATIONS AND BLANK FORMS

Refer to the latest issue of DA PAM 25-30 to determine whether there are new additions, changes, or additional publications pertaining to the equipment.

MAINTENANCE FORMS, RECORDS, AND REPORTS

- (1) (Army) Department of the Army forms and procedures used for equipment maintenance will be those prescribed by (as applicable) DA PAM 750-8, The Army Maintenance Management System (TAMMS) User Manual; DA PAM 738-751, Functional users Manual for the Army Maintenance Management Systems - Aviation (TAMMS-A); or AR 700-138, Army Logistics Readiness and Sustainability.
- (2) (Air Force) Maintenance forms and records used by Air Force personnel are prescribed in AFI 21-101 and the applicable TO 00-20 Series Technical Orders.

REPORTING EQUIPMENT IMPROVEMENT RECOMMENDATIONS (EIR)

- (1) (Army) If your equipment needs improvement, let us know. Send us an EIR. You, the user, are the only one who can tell us what you don't like about your equipment. Let us know why you don't like the design or performance. If you have Internet access, the easiest and fastest way to report problems or suggestions is to go to <https://aeps.ria.army.mil/aepspublic.cfm> (scroll down and choose the "Submit Quality Deficiency Report" bar). The Internet form lets you choose to submit an Equipment Improvement Recommendation (EIR), a Product Quality Deficiency Report (PQDR or a Warranty Claim Action (WCA). You may also submit your information using an SF 368 (Product Quality Deficiency Report). You can send your SF 368 via e-mail, regular mail, or facsimile using the addresses/facsimile numbers specified in DA PAM 750-8, The Army Maintenance Management System (TAMMS) Users Manual. We will send you a reply.
- (2) (Air Force) Air Force personnel are encouraged to submit EIR's in accordance with AFR 900-4.

CORROSION PREVENTION AND CONTROL (CPC)

Corrosion Prevention and Control (CPC) of Army materiel is a continuing concern. It is important that any corrosion problems with this item be reported so that the problem can be corrected and improvements can be made to prevent the problem in future items.

Corrosion specifically occurs with metals. It is an electrochemical process that causes the degradation of metals. It is commonly caused by exposure to moisture, acids, bases, or salts. An example is the rusting of iron. Corrosion damage in metals can be seen, depending on the metal, as tarnishing, pitting, fogging, surface residue, and/or cracking.

Plastics, composites, and rubbers can also degrade. Degradation is caused by thermal (heat), oxidation (oxygen), solvation (solvents), or photolytic (light, typically ultraviolet (UV) processes. The most common exposures are excessive heat or light. Damage from these processes will appear as cracking, softening, swelling, and/or breaking.

The form should be submitted to the address specified in DA PAM 738-750, Functional Users Manual for the Army Maintenance Management System (TAMMS).

DESTRUCTION OF ARMY MATERIEL TO PREVENT ENEMY USE

Refer to TM 750-244-6 for demolition procedures when equipment destruction is required.

PREPARATION FOR STORAGE OR SHIPMENT

Refer to Preparation for Storage or Shipment work package (WP 0031 00).

WARRANTY INFORMATION

Refer to Warranty Technical Bulletin, TB 9-6115-643-24, for warranty information.

LIST OF ABBREVIATIONS/ACRONYMS

<u>Abbreviation/Acronym</u>	<u>Definition</u>
A	Ampere
ATTN	Attention
AVIM	Aviation Intermediate Maintenance
AVUM	Aviation Unit Maintenance
BD	Bundle
bhp	Brake horsepower
BOI	Basis of Issue
BX	Box
CAGEC	Commercial and Government Entity Code
CARC	Chemical Agent Resistant Coating
CCW	Counterclockwise
Chp	Chapter
cm	Centimeter
CN	Carton
CPC	Corrosion Prevention and Control
CW	Clockwise
DC	Direct Current
DIA	Diameter
EIC	End Item Code
EIR	Equipment Improvement Recommendations
EMP	Electromagnetic Pulse
ESD	Electrostatic Discharge
FGC	Functional Group Code
FIG	Figure
gal	Gallon
gph	Gallons Per Hour
HCI	Hardness Critical Item
HZ	Hertz
I.D.	Identification
IDN	Initial Distribution Number
in.	Inch
ISO	International Standards Organization
kg	Kilogram

LIST OF ABBREVIATIONS/ACRONYMS - Continued

<u>Abbreviation/Acronym</u>	<u>Definition</u>
kPa	Kilopascal
KW	Kilowatt
L	Liter
lb	Pound
lb-ft	Pound-foot
lph	Liters Per Hour
m	Meter
MAC	Maintenance Allocation Chart
MI	Modification Instructions
mm	Millimeter
mmHz	Millimeter Per Hertz
MPa	Megapascal
MTOE	Modified Table of Organization and Equipment
MWO	Modification Work Order
N/A	Not Applicable
NBC	Nuclear, Biological, and Chemical
NHA	Next Higher Assembly
NIIN	National Item Identification Code
Nm	Newton-Meter
No.	Number
NSN	National Stock Number
OS	Oversize
OSHA	Occupational Safety and Health Act
P/N	Part Number
Pc	Control Pressure
PG	Package
PMCS	Preventive Maintenance Checks and Services
psi	Pounds Per Square Inch
qt	Quart
QTY	Quantity
REF	Reference
RL	Roll
rpm	Revolutions Per Minute
RPSTL	Repair Parts and Special Tools List
SAE	Society of Automotive Engineers
SMR	Source, Maintenance, and Recoverability
SRA	Specialized Repair Activity
TAMMS	The Army Maintenance Management System

LIST OF ABBREVIATIONS/ACRONYMS - Continued

<u>Abbreviation/Acronym</u>	<u>Definition</u>
TB	Technical Bulletin
TDC	Top Dead Center
TM	Technical Manual
TMDE	Test, Measurement, and Diagnostic Equipment
TQ	Tactical Quiet
TU	Tube
U/I	Unit of Issue
UOC	Useable On Code
USEPA	U.S. Environmental Protection Agency
UUT	Unit Under Test
UV	Ultraviolet
Vdc	Volts, Direct Current
W	Watt
WP	Work Package
°C	Degrees Celsius
°F	Degrees Fahrenheit

QUALITY OF MATERIAL

Material used for replacement, repair, or modification must meet the requirements of this TM. If quality of material requirements are not stated in this manual, the material must meet the requirements of the drawings, standards, specifications, or approved engineering change proposals applicable to the subject equipment.

SAFETY, CARE, AND HANDLING

The diesel engine contains no radioactive components or parts or radioactive material requiring special handling or consideration. The diesel engine contains no electronic modules or components requiring special handling to protect them from Electrostatic Discharge (ESD).

This manual describes physical and chemical processes that may require the use of chemicals, solvents, paints, or other commercially available material. Users of the manual should obtain the material safety data sheets (Occupational Safety and Health Act (OSHA) Form 20 or equivalent) from the manufacturers or suppliers of materials to be used. Users must be completely familiar with manufacturer/supplier information and adhere to their procedures, recommendations, warnings, and cautions for safe use, storage, and disposal of these materials.

COMMON TOOLS AND TEST EQUIPMENT

For authorized common tools and equipment, refer to the Modified Table of Organization and Equipment (MTOE), CTA 50-970, Expendable/Durable Items (Except: Medical, Class V, Repair Parts, and Heraldic Items), or CTA 8-100, Army Medical Department Expendable/Durable Items, as applicable to your unit.

SPECIAL TOOLS; TEST, MEASUREMENT, AND DIAGNOSTIC EQUIPMENT (TMDE); AND SUPPORT EQUIPMENT

Special tools; TMDE; and support equipment are needed for field level maintenance. They are listed in the Repair Parts and Special Tools List (RPSTL) work packages (WP 0036 00 thru WP 0063 00) and in the Maintenance Allocation Chart (MAC) work package (WP 0035 00).

REPAIR PARTS

Repair parts are listed and illustrated in the RPSTL work packages (WP 0036 00 thru WP 0063 00).

**FIELD LEVEL
DIESEL ENGINE, 4TNV84T-DFM
NSN 2815-01-538-4237
EQUIPMENT DESCRIPTION AND DATA**

EQUIPMENT CHARACTERISTICS, CAPABILITIES, AND FEATURES

The diesel engine is four cylinder, four cycle, fuel injected, turbocharged, and liquid cooled. The firing order is 1-3-4-2. The number one cylinder is toward the flywheel end of the engine. The serial number is located on the engine name plate on top of the valve cover assembly. Rotation of the engine is Counterclockwise (CCW) as viewed from the flywheel end. The engine can operate using diesel fuel or aviation fuel. In accordance with U.S. Environmental Protection Agency (USEPA) requirements, several features have been incorporated to reduce engine exhaust emissions and noise. These include an oil pump built into the front gear assembly and driven by the gears, optimal installation of the fuel injectors vertically and in the center of the cylinders, low suction volume and multiple injection holes of the fuel injectors, mono injection plunger with higher injection pressure on the injection pump, and a new design of the combustion chamber.

LOCATION AND DESCRIPTION OF MAJOR COMPONENTS**Fuel Filter**

The fuel filter (figure 1, sheet 1, item 1) provides additional filtering of the fuel before it enters the fuel injection pump.

Flywheel Assembly

The flywheel assembly (figure 1, sheet 1, item 2) is weighted and balanced to help reduce vibration and provide smooth output from the engine. The flywheel is geared to engage the starter motor assembly.

Starter Motor Assembly

The starter motor assembly (figure 1, sheet 1, item 3) is located on the left rear side of the engine. The electric starter engages the flywheel mechanically to start the diesel engine.

Batter Charging Alternator (24 Vdc)

The battery charging alternator (figure 1, sheet 1, item 4) is located on the left side of the engine. The battery charging alternator provides 24 Vdc to maintain the starting batteries in a state of full charge and to power engine accessories.

Fuel Injection Pump Assembly

The fuel injection pump assembly (figure 1, sheet 2, item 5) provides high pressure fuel to the fuel injectors.

Oil Filter

The oil filter (figure 1, sheet 2, item 6) removes contaminants from the engine oil to maintain a clean supply of oil to lubricate the moving parts of the engine.

Oil Dipstick

The oil dipstick (figure 1, sheet 2, item 7) provides a means of checking the oil level of the engine.

Turbocharger Assembly

The turbocharger assembly (figure 1, sheet 2, item 8) is powered by engine exhaust gases. It compresses and speeds up the airflow from the air filter to provide pressurized air to the engine for better combustion and more power without increased fuel consumption.

LOCATION AND DESCRIPTION OF MAJOR COMPONENTS - Continued**Sensor Switches**

The primary sensor switches on the engine are the coolant temperature switch (figure 1, sheet 3, item 9) and oil pressure switch (figure 1, sheet 3, item 13).

Water Pump Assembly

The water pump assembly (figure 1, sheet 3, item 10) is a belt-driven pump used to pump coolant throughout the engine.

Oil Fill Cap

The oil fill cap (figure 1, sheet 3, item 11) is removed to allow refilling of the oil reservoir with engine oil.

Gear Case Assembly

The gear case assembly (figure 1, sheet 3, item 12) is a cover which contains the direct-driven oil pump. The gear case also covers/protects the fuel injection pump assembly gear, idle gear, and camshaft gear.

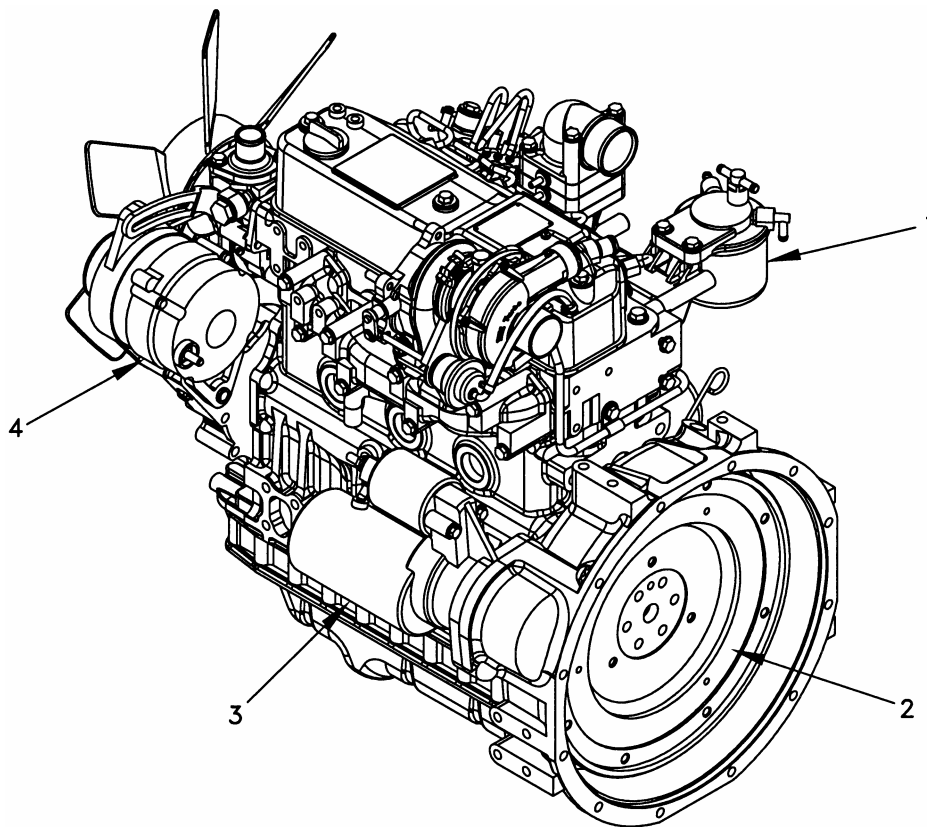

15KW-2815-24M-349

Figure 1. Diesel Engine (Sheet 1 of 3).

LOCATION AND DESCRIPTION OF MAJOR COMPONENTS - Continued

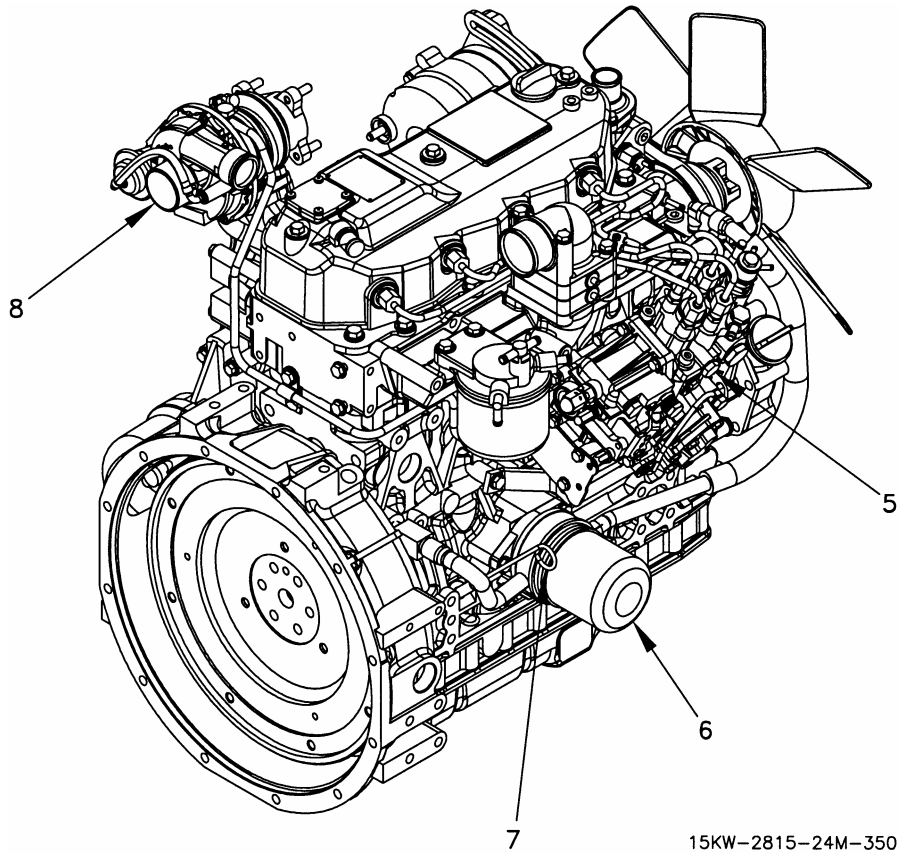

Figure 1. Diesel Engine (Sheet 2 of 3).

LOCATION AND DESCRIPTION OF MAJOR COMPONENTS - Continued

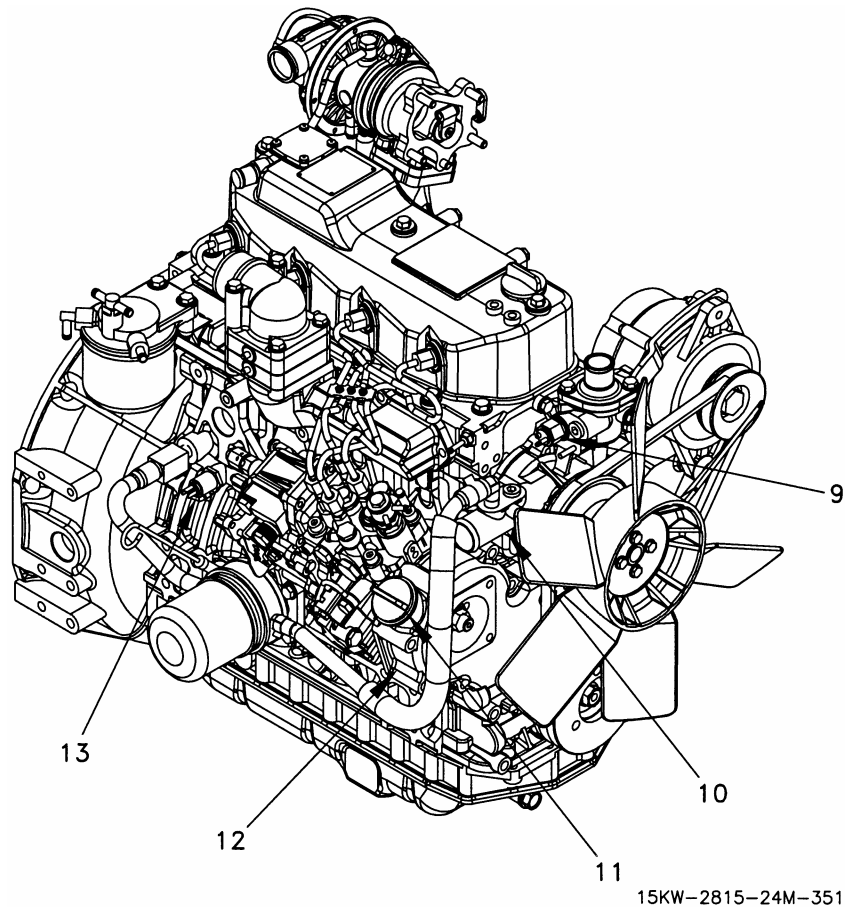

Figure 1. Diesel Engine (Sheet 3 of 3).

EQUIPMENT DATA

Table 1 lists equipment data for the diesel engine.

Table 1. Diesel Engine Equipment Data

EQUIPMENT	DATA
Overall length Width Height Weight (dry)	27.53 in. (69.9 cm) 20.18 in. (51.3 cm) 26.52 in. (67.4 cm) 419 lb (190 kg)
Manufacturer Model Part number Type Bore Stroke Displacement Compression ratio Valves per cylinder Valve lash setting (cold engine) Inlet Exhaust	Yanmar 4TNV84T 4TNV84T-DFM Four cylinder, in-line, four cycle, turbocharged diesel 3.307 in. (84 mm) 3.543 in. (90 mm) 121.7 in ³ (1.995L) 20:1 4 (2 inlet; 2 exhaust) 0.0059 to 0.098 in. (0.15 to 0.25 mm) 0.0059 to 0.098 in. (0.15 to 0.25 mm)
Cooling system Type Normal operating temperature Thermostat opening Thermostat full open	Designed for pressurized radiator and coolant pump 170°F to 200°F (77°C to 93°C) 157°F to 162.5°F (69.5°C to 72.5°C) 185°F (85°C)
Lubrication system Type Pump type Capacity Normal operating pressure	Forced lubrication Trochoid, engine gear driven 6 qt (5.7L) 43 to 56 psi (294 to 391 kPa)
Fuel system Fuel type Fuel consumption rate	DF-1, DF-2, DF-A, JP-4, JP5, JP8 1.5 gph (5.7 lph)
Rated loads	33 bhp at 1,500 rpm 40 bhp at 1,800 rpm 44 bhp at 2,000 rpm
Torque available	116 lb-ft (157.3 Nm) at 1,800 rpm

EQUIPMENT DATA - Continued

Table 1. Diesel Engine Equipment Data - Continued

EQUIPMENT	DATA
Engine electrical system	
Batteries	12 Vdc; quantity 2 in series (24 Vac)
Starter motor assembly	
Manufacturer	Yanmar
Part number	129612-7701
Voltage rating	24 Vdc
Drive type	Direct
Battery charging alternator (24 Vdc)	
Manufacturer	Yanmar
Part number	129900-77240
Voltage rating	24 Vdc
Drive type	Belt drive
Amperage Rating	35A at 24 Vdc
Starting aid	24 Vdc, 800W intake air preheater
Protection devices	
Low oil pressure switch	
Trip pressure	11.4 psi (0.8 kg/cm ²)
Voltage rating	24 Vdc
Coolant high temperature switch	
Trip temperature	225°F to 235°F (107°C to 112°C)
Voltage rating	24 Vdc

**FIELD LEVEL
DIESEL ENGINE, 4TNV84T-DFM
NSN 2815-01-538-4237
THEORY OF OPERATION**

GENERAL

This work package contains functional descriptions of the diesel engine and explains how engine functional systems interact with one another.

ENGINE OVERVIEW

The engine is an in-line four cylinder turbocharged diesel engine with a firing order of 1-3-4-2 (cylinder number 1 is located at the flywheel end of the engine). Each cylinder utilizes four non-hydraulic, adjustable valves (two intake and two exhaust) for a total of 16 valves. The gear-driven cam shaft operates push rods that operate the rocker arms to open each pair of valves. Each valve pair operate together using a valve bridge. The valve pairs allow greater air flow into and out of the cylinders to increase engine performance. The engine rotation is CCW when viewed from the flywheel end. The cylinder bore is 3.307 inches (84 mm) and the stroke is 3.543 inches (90 mm), providing a total displacement of 121.7 cubic inches (1.995L). The fuel injection pump assembly provides increased control of timing and fuel air mixture. The timing advance is achieved by precise control of the unit injector timing.

ENGINE STARTING AND BATTERY CHARGING COMPONENTS

The engine has a starter motor assembly, with integral starter solenoid, which will engage the flywheel and rotate the engine so that it will start. There is a set of two 12 volt, 400 watt heaters which are wired in series and connected to an external 24 Vdc source in order to warm the inlet air just prior to entering the intake manifold in cold weather. There is a 35 amp battery charging alternator (24 Vdc), belt driven from pulleys on the front of the engine, which can be used to recharge the batteries used to start the engine and used to run engine accessories after the engine is operating. (The battery charging alternator (24 Vdc) requires batteries, or equivalent, for voltage regulation of the battery charging alternator (24 Vdc) output.)

FUEL SYSTEM

The fuel system (figure 1) consists of a fuel tank (or equivalent source of fuel), piping, fuel filter/water separator, electric fuel pump, fuel filter, injection pump, and injectors. Fuel is drawn from the fuel tank by the electric fuel pump. Fuel then passes through the fuel/water separator where water and small impurities are removed. The fuel then passes through the fuel filter to the low pressure port of the gear-driven fuel pump and to the accumulator. The accumulator is used to maintain constant fuel pump pressure by compensating for small fluctuations in fuel pressure. The pressure control valve regulates fuel pump pressure. Pressurized fuel from the fuel pump is applied to the gear-driven fuel distributor which supplies fuel to the injection pump based on engine timing. When a particular cylinder is near the end of a compression cycle, the fuel distributor enables fuel flow to that cylinder's fuel injector nozzle. Whenever the fuel distributor aligns with a cylinder, the cam will actuate the plunger in the injection pump, forcing high pressure fuel into that cylinder's fuel injector nozzle. This cycle is repeated for each of the four cylinders. The fuel that is not used is returned to the fuel tank via an excess fuel return line.

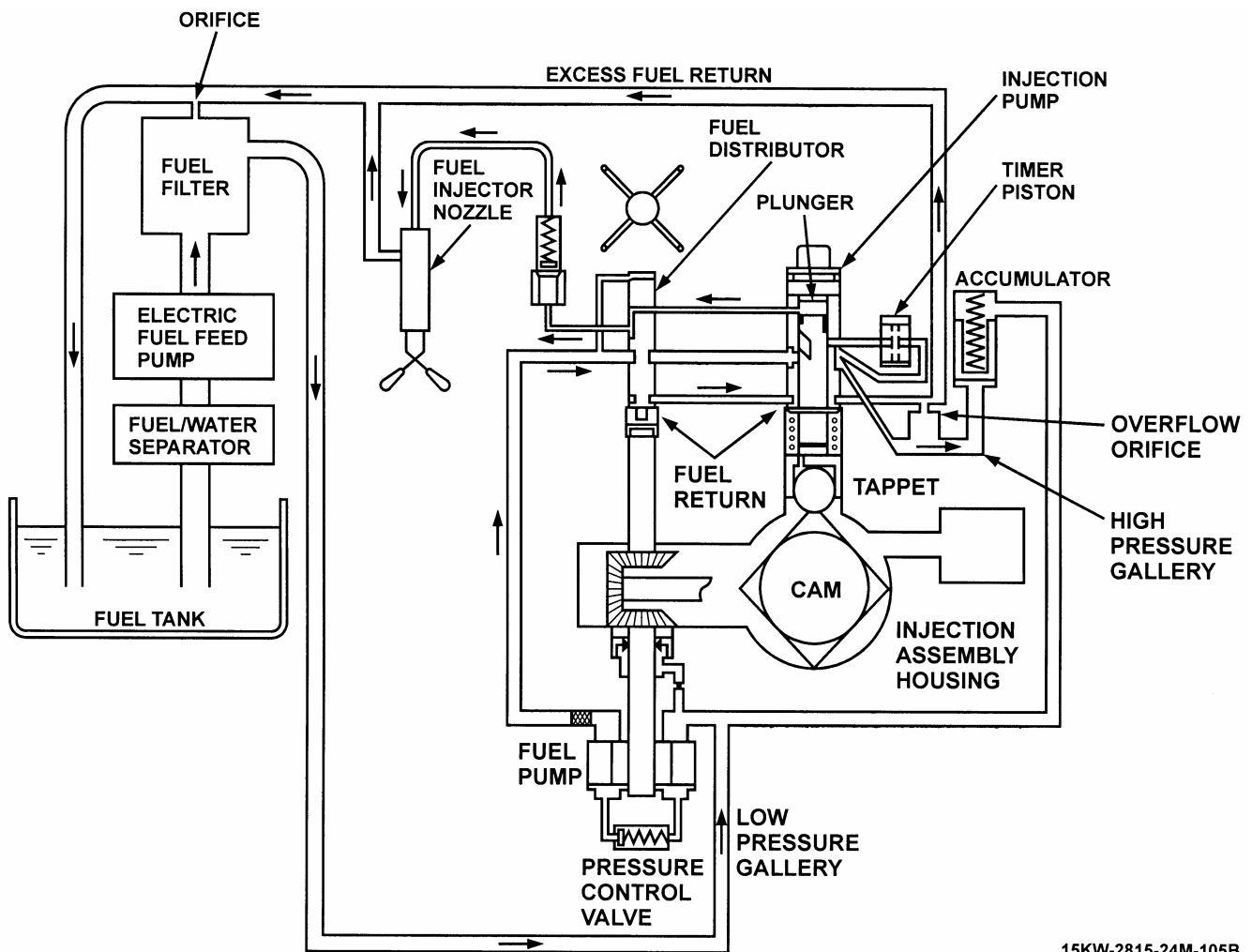

15KW-2815-24M-105B

Figure 1. Fuel System.

ENGINE COOLING SYSTEM

The engine cooling system (figure 2) consists of a water pump, thermostat, belt-driven fan, and cooling jackets. The water pump is located on the front of the cylinder block and is belt driven from the crankshaft pulley. The water pump forces coolant through passages (cooling jackets) in the engine block and cylinder head where the coolant absorbs heat from the engine. When the engine reaches normal operating temperature, the thermostat opens and the heated coolant flows out of the engine through the upper coolant hose assembly to a fluid cooler (radiator). A belt-driven cooling fan on the front of the engine is used to draw air through the radiator to reduce the temperature of the engine coolant. Coolant is drawn from the bottom of the external cooling device by the water pump and circulated through the engine.

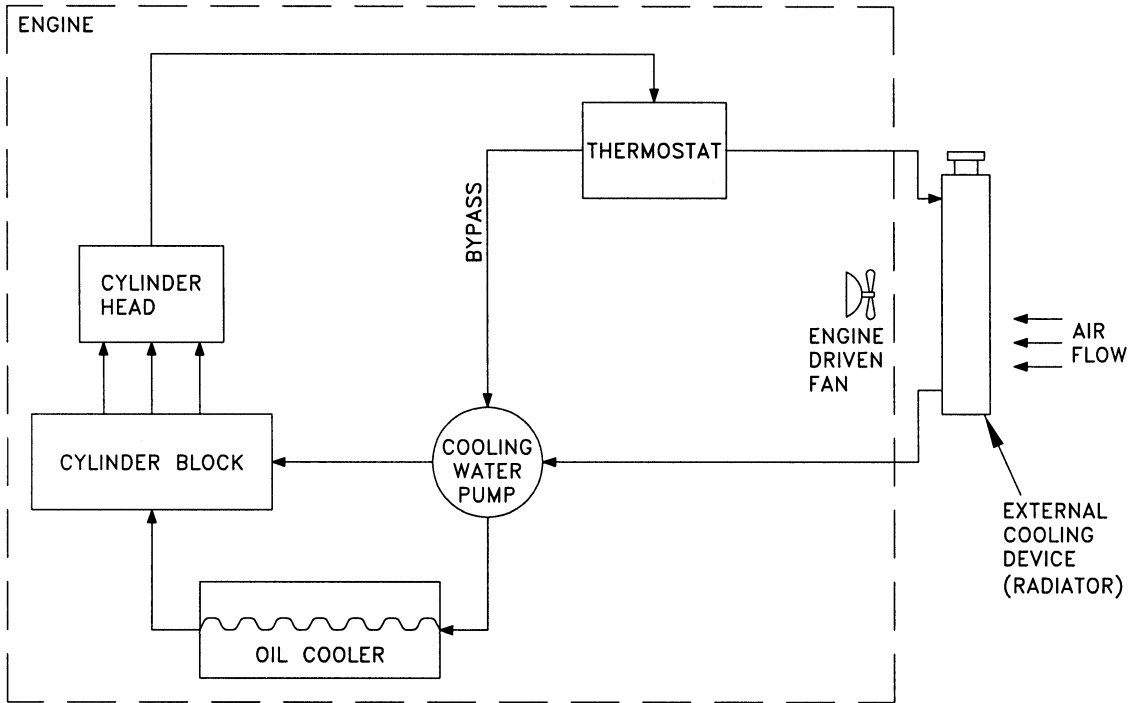

15KW-2815-24M-106A

Figure 2. Engine Cooling System.

LUBRICATION SYSTEM

The engine oil pump (figure 3) is located inside the gear case assembly and is driven directly by the crankshaft. The engine oil pump pulls oil from the engine oil pan through the oil suction pipe and pushes the oil through the regulator valve, bypass valve, and oil cooler to the oil filter. The regulator valve regulates and stabilizes the engine oil pressure with the engine running at rated rpm. The bypass valve allows oil to flow through the engine if the oil filter becomes clogged. From the oil filter, oil flows to the main oil gallery in the cylinder head. The main oil gallery distributes oil to crankshaft journals, camshaft bearings, fuel injection pump assembly, and turbocharger. The fuel injection pump receives oil from the main gallery which it supplies to the turbocharger. If oil pressure drops, the oil pressure switch sends a signal to the control panel to indicate low oil pressure. All oil eventually flows back into the oil pan for recirculation.

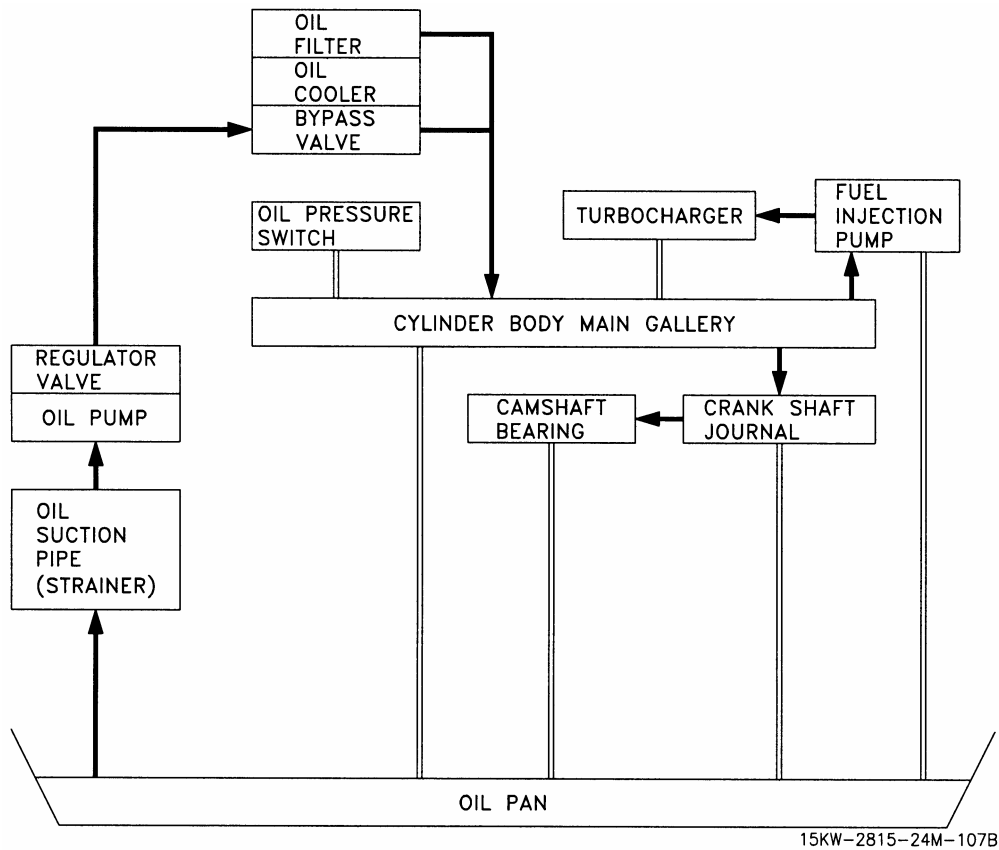
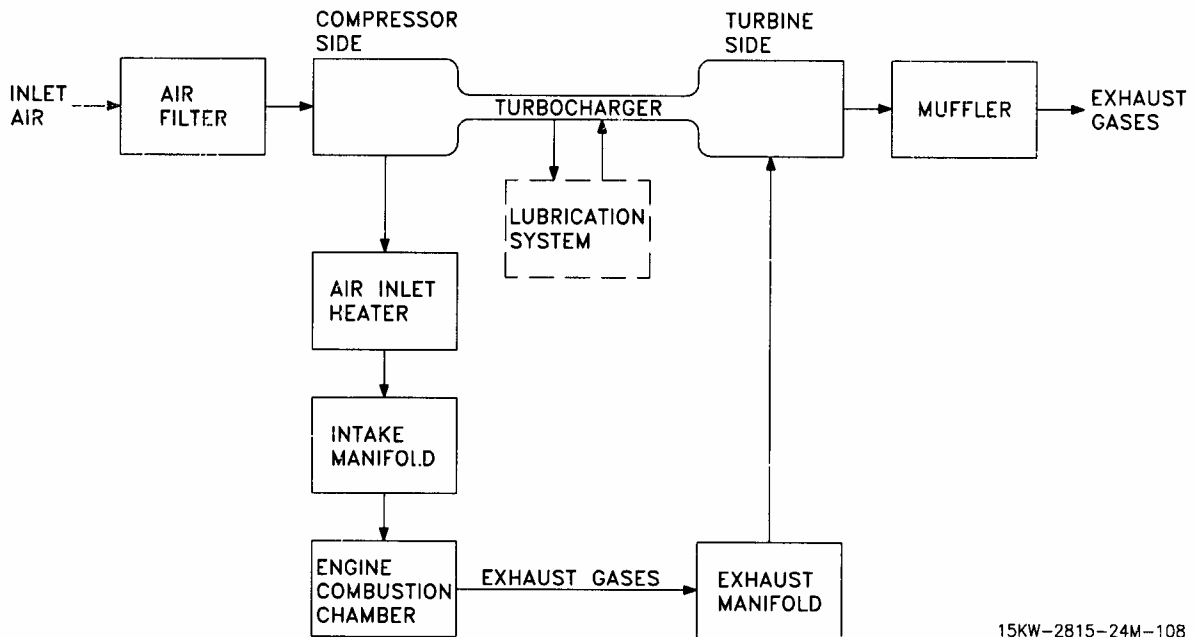

Figure 3. Lubrication System.

AIR INLET AND EXHAUST SYSTEM

The air intake and exhaust system (figure 4) consists of an air inlet heater, intake manifold, turbocharger, and exhaust manifold. An air filter assembly and a muffler as shown in the diagram are recommended for use with this engine. Ambient air is drawn into the air filter assembly where airborne dirt is removed and trapped. Filtered air is drawn through the air intake tubes to the turbocharger where it is pressurized. In cold weather, an air inlet heater is activated to warm the inlet air. The pressurized inlet air enters the intake manifold to the combustion chambers and mixes with fuel from the fuel injectors. The engine exhaust gases are released into the turbocharger which is mounted on the exhaust manifold. The exhaust gases drive the turbocharger, forcing large amounts of clean air into the intake manifold. After passing through the turbocharger, the exhaust gases are channeled into a muffler to deaden the sound. The exhaust gases should be vented away from the engine.



15KW-2815-24M-108

Figure 4. Air Inlet and Exhaust System.

CHAPTER 2
TROUBLESHOOTING PROCEDURES
FOR
DIESEL ENGINE

CHAPTER 2

TROUBLESHOOTING PROCEDURES FOR DIESEL ENGINE

WORK PACKAGE INDEX

<u>Title</u>	<u>WP Sequence No.</u>
TROUBLESHOOTING INDEX	0004 00
TROUBLESHOOTING PROCEDURES	0005 00

**FIELD LEVEL
DIESEL ENGINE, 4TNV84T-DFM
NSN 2815-01-538-4237
TROUBLESHOOTING INDEX**

TROUBLESHOOTING INDEX

<u>Malfunction/Symptom</u>	<u>Work Package and Page No.</u>
1. Engine does not start (slow starter motor assembly rotation or no starter motor assembly rotation)....	0005 00-1
2. Engine does not start (engine turns over at normal speed).....	0005 00-2
3. Engine starts, but soon stops, with little or no exhaust smoke	0005 00-4
4. Engine starts, but soon stops, with excessive exhaust smoke	0005 00-5
5. Insufficient engine output with normal exhaust color	0005 00-6
6. Insufficient engine output with white exhaust smoke	0005 00-7
7. Insufficient engine output with black exhaust smoke	0005 00-9
8. Excessive white smoke while under load.....	0005 00-10
9. Excessive black smoke while under load.....	0005 00-12
10. High knocking sound during combustion	0005 00-14
11. Abnormal combustion sound	0005 00-14
12. Uneven combustion sound.....	0005 00-15
13. Uneven engine speed (hunting) while idling.....	0005 00-16
14. Uneven engine speed (hunting) while under load.....	0005 00-16
15. Excessive engine vibration.....	0005 00-17
16. Excessive turbocharger assembly vibration or noise	0005 00-18
17. Slow turbocharger assembly response	0005 00-18
18. Difficulty with engine when returning from high speed to low speed.....	0005 00-18
19. Excessive fuel consumption.....	0005 00-19
20. Excessive oil consumption	0005 00-19
21. Fuel in engine oil	0005 00-20
22. Oil mixed with coolant	0005 00-20
23. Low oil pressure	0005 00-21
24. Excessive blow-by gas	0005 00-21
25. Engine overheats	0005 00-22
26. Low coolant temperature.....	0005 00-24
27. Air intake pressure drops	0005 00-24
28. Air intake pressure rises.....	0005 00-25
29. Exhaust temperature rises	0005 00-25

**FIELD LEVEL
DIESEL ENGINE, 4TNV84T-DFM
NSN 2815-01-538-4237
TROUBLESHOOTING PROCEDURES**

INITIAL SETUP:**Tools and Special Tools**

Tool kit, general mechanic's
(item 5, WP 0035 00)
Shop equipment, automotive, common
no. 1 (item 2, WP 0035 00)
Shop equipment, automotive, supplemental
set no. 2 (item 1, WP 0035 00)

References

WP 0010 00
WP 0012 00 and WP 0013 00
WP 0016 00 and WP 0017 00
WP 0019 00 and WP 0020 00
WP 0022 00
WP 0024 00 and WP 0025 00
WP 0027 00 and WP 0028 00
End item configuration manual

Personnel Required

One

INTRODUCTION

This work package contains troubleshooting information with a list of symptoms, malfunctions, tests/inspections, and corrective actions required to return the diesel engine to normal operation. The tests/inspections and corrective actions should be performed in the order listed. If the first corrective action step is normal, proceed to the next step. The corrective actions will refer to a work package in this manual or the end item configuration manual. Troubleshooting procedures in this manual cannot list all possible malfunctions or tests/inspections required for corrective action. If a symptom/malfunction is not listed or is not corrected by the listed corrective action, refer to the end item configuration manual troubleshooting procedures.

TROUBLESHOOTING PROCEDURES**SYMPTOM**

Engine does not start (slow starter motor assembly rotation or no starter motor assembly rotation).

MALFUNCTION

Battery charging alternator (24 Vdc) malfunction.

CORRECTIVE ACTION

1. Gain access to batteries (end item configuration manual).
2. Start engine (end item configuration manual). Set engine speed to at least 1,000 rpm.
3. Measure Direct Current (DC) voltage across batteries. Voltage should be 26.4 to 31.0 Vdc.
4. If voltage is above or below limit, replace battery charging alternator (24 Vdc) (WP 0010 00).

MALFUNCTION

Battery voltage drop.

CORRECTIVE ACTION

1. Inspect connections (end item configuration manual).
2. Charge battery (end item configuration manual).
3. Replace battery (end item configuration manual).

TROUBLESHOOTING - Continued**SYMPTOM - Continued**

Engine does not start (slow starter motor assembly rotation or no starter motor assembly rotation) - Continued.

MALFUNCTION

Starter circuit defect.

CORRECTIVE ACTION

1. Check starter motor assembly cables/connections for looseness/corrosion; tighten/clean as required.
2. Temporarily connect starter motor assembly SWITCH terminal to battery positive terminal:
 - a. If starter motor assembly spins, starter motor assembly is operating properly; troubleshoot starter motor assembly circuitry (end item configuration manual).
 - b. If starter motor assembly does not turn, starter motor assembly is defective; replace as required (WP 0019 00).

MALFUNCTION

Incorrect oil grade/type (for ambient temperature range).

CORRECTIVE ACTION

Drain oil; fill with correct oil (end item configuration manual).

SYMPTOM

Engine does not start (engine turns over at normal speed).

MALFUNCTION

No fuel (fuel tank empty).

CORRECTIVE ACTION

Check fuel tank; fill as required (end item configuration manual).

MALFUNCTION

No fuel (insufficient fuel supply at fuel injection pump assembly).

CORRECTIVE ACTION

1. Check fuel/water separator and filter; replace as required (end item configuration manual).
2. Check fuel filter; clean as required (WP 0017 00).
3. Check fuel lines and hoses for clogs/leaks; repair as required (WP 0017 00 and end item configuration manual).

MALFUNCTION

No fuel (fuel injection assembly failure).

CORRECTIVE ACTION

Replace fuel injection pump assembly (WP 0016 00).

TROUBLESHOOTING - Continued**SYMPTOM - Continued**

Engine does not start (engine turns over at normal speed) - Continued.

MALFUNCTION

No fuel (clogged fuel filter).

CORRECTIVE ACTION

1. Check fuel filter; clean as required (WP 0017 00).
2. Check fuel filter; replace as required (WP 0017 00).

MALFUNCTION

No fuel (clogged or leaking fuel line).

CORRECTIVE ACTION

Check fuel lines and hoses for clogs/leaks; repair/replace as required (WP 0017 00 and end item configuration manual).

MALFUNCTION

Water in fuel system.

CORRECTIVE ACTION

1. Drain fuel tank and fuel lines and hoses (WP 0017 00, WP 0020 00, and end item configuration manual).
2. Drain water from fuel filter (WP 0017 00).
3. Fill fuel system with clean dry fuel (end item configuration manual).

MALFUNCTION

Air in fuel system.

CORRECTIVE ACTION

Bleed fuel system (end item configuration manual).

MALFUNCTION

Improper intake/exhaust valve clearance.

CORRECTIVE ACTION

Adjust valve lash (WP 0025 00).

MALFUNCTION

Improper open or close timing of intake/exhaust valves.

CORRECTIVE ACTION

Adjust valve lash (WP 0025 00).

MALFUNCTION

Internal engine problem

CORRECTIVE ACTION

Replace engine (end item configuration manual).

TROUBLESHOOTING - Continued**SYMPTOM**

Engine starts, but soon stops, with little or no exhaust smoke.

MALFUNCTION

No fuel (fuel tank empty).

CORRECTIVE ACTION

Check fuel tank; fill as required (end item configuration manual).

MALFUNCTION

Clogged fuel filter.

CORRECTIVE ACTION

1. Check fuel filter; clean as required (WP 0017 00).
2. Check fuel filter; repair/replace as required (WP 0017 00).

MALFUNCTION

Clogged or leaking fuel line.

CORRECTIVE ACTION

Check fuel lines and hoses for clogs/leaks; repair/replace as required (WP 0017 00 and end item configuration manual).

MALFUNCTION

Air in fuel system.

CORRECTIVE ACTION

Bleed fuel system (end item configuration manual).

MALFUNCTION

Insufficient oil level (low oil pressure shutdown).

CORRECTIVE ACTION

Add oil to proper level (end item configuration manual).

MALFUNCTION

Incorrect oil grade/type for ambient temperature range (low oil pressure shutdown).

CORRECTIVE ACTION

Drain oil; fill with correct oil (end item configuration manual).

MALFUNCTION

Malfunctioning governor.

CORRECTIVE ACTION

Adjust/repair/replace governor as required (end item configuration manual).

TROUBLESHOOTING - Continued**SYMPTOM - Continued**

Engine starts, but soon stops, with little or no exhaust smoke - Continued.

MALFUNCTION

Insufficient fuel supply at fuel injection pump assembly.

CORRECTIVE ACTION

1. Check fuel/water separator and filter; replace as required (end item configuration manual).
2. Check fuel filter; replace as required (WP 0017 00).
3. Check fuel lines and hoses for clogs/leaks; repair as required (WP 0017 00, WP 0020 00, and end item configuration manual).

MALFUNCTION

Improper intake/exhaust valve clearance.

CORRECTIVE ACTION

Adjust valve lash (WP 0025 00).

MALFUNCTION

Internal engine problem.

CORRECTIVE ACTION

Replace engine (end item configuration manual).

SYMPTOM

Engine starts, but soon stops, with excessive exhaust smoke.

MALFUNCTION

Clogged air filter.

CORRECTIVE ACTION

Clean/replace air filter (end item configuration manual).

MALFUNCTION

Water in fuel system.

CORRECTIVE ACTION

1. Drain fuel tank and fuel lines and hoses (WP 0017 00, WP 0020 00, and end item configuration manual).
2. Drain water from fuel filter (end item configuration manual).
3. Fill fuel system with clean dry fuel (end item configuration manual).

MALFUNCTION

Internal engine problem.

CORRECTIVE ACTION

Replace engine (end item configuration manual).

TROUBLESHOOTING - Continued**SYMPTOM**

Insufficient engine output with normal exhaust color.

MALFUNCTION

Clogged fuel filter.

CORRECTIVE ACTION

Replace fuel filter (WP 0017 00).

MALFUNCTION

Air in fuel system.

CORRECTIVE ACTION

Bleed air from fuel system (end item configuration manual).

MALFUNCTION

Clogged or leaking fuel line.

CORRECTIVE ACTION

Check fuel lines and hoses for clogs/leaks; repair/replace as required (WP 0017 00).

MALFUNCTION

Incorrect oil grade/type (for ambient temperature range)

CORRECTIVE ACTION

Drain oil; fill with correct oil (end item configuration manual).

MALFUNCTION

Incorrect fuel grade/type (for ambient temperature range).

CORRECTIVE ACTION

Drain fuel system; fill with correct fuel (end item configuration manual).

MALFUNCTION

Insufficient fuel supply to fuel injectors.

CORRECTIVE ACTION

1. Check fuel/water separator and filter; replace as required (end item configuration manual).
2. Check fuel filter; replace as required (WP 0017 00).
3. Check fuel injection pump assembly; replace as required (WP 0016 00).
4. Check fuel lines and hoses for clogs/leaks; repair as required (WP 0017 00).

MALFUNCTION

Clogged strainer at feed pump inlet.

CORRECTIVE ACTION

Clean strainer (end item configuration manual).

TROUBLESHOOTING - Continued**SYMPTOM - Continued**

Insufficient engine output with normal exhaust color - Continued.

MALFUNCTION

Improper intake/exhaust valve clearance.

CORRECTIVE ACTION

Adjust valve lash (WP 0025 00).

MALFUNCTION

Compression leakage from valve seat.

CORRECTIVE ACTION

Replace cylinder head assembly (WP 0024 00).

MALFUNCTION

Leaking cylinder head assembly gasket.

CORRECTIVE ACTION

Replace cylinder head assembly gasket (WP 0024 00).

MALFUNCTION

Internal engine problem.

CORRECTIVE ACTION

Replace engine (end item configuration manual).

SYMPTOM

Insufficient engine output with white exhaust smoke.

MALFUNCTION

Incorrect fuel grade/type (for ambient temperature range).

CORRECTIVE ACTION

Drain fuel system; fill with correct fuel (end item configuration manual).

MALFUNCTION

Water in fuel system.

CORRECTIVE ACTION

1. Drain fuel tank and fuel lines and hoses (WP 0017 00, WP 0020 00, and end item configuration manual).
2. Drain water from fuel filter (end item configuration manual).
3. Fill fuel system with clean dry fuel (end item configuration manual).

TROUBLESHOOTING - Continued**SYMPTOM - Continued**

Insufficient engine output with white exhaust smoke - Continued.

MALFUNCTION

Too late timing of fuel injection pump assembly.

CORRECTIVE ACTION

Check fuel injection pump assembly; adjust timing (WP 0016 00).

MALFUNCTION

Uneven volume of fuel from fuel injectors.

CORRECTIVE ACTION

Check fuel injection pump assembly and fuel injectors; replace as required (WP 0016 00 and WP 0022 00).

MALFUNCTION

Poor spray pattern from fuel injector nozzle.

CORRECTIVE ACTION

Check fuel injectors; replace as required (WP 0022 00).

MALFUNCTION

Worn intake/exhaust valve guides.

CORRECTIVE ACTION

Replace cylinder head assembly (WP 0024 00).

MALFUNCTION

Improper open or close timing of intake/exhaust valves.

CORRECTIVE ACTION

Adjust valve lash (WP 0025 00).

MALFUNCTION

Worn turbocharger assembly bearing.

CORRECTIVE ACTION

Replace turbocharger assembly (WP 0028 00).

MALFUNCTION

Internal engine problem.

CORRECTIVE ACTION

Replace engine (end item configuration manual).

TROUBLESHOOTING - Continued**SYMPTOM**

Insufficient engine output with black exhaust smoke.

MALFUNCTION

Fouled turbocharger assembly.

CORRECTIVE ACTION

Inspect turbocharger assembly; clean as required (WP 0028 00).

MALFUNCTION

Turbocharger assembly waste gate malfunction.

CORRECTIVE ACTION

Test/inspect turbocharger assembly waste gate; replace as required (WP 0028 00).

MALFUNCTION

Defective thermostat.

CORRECTIVE ACTION

Check thermostat; replace as required (WP 0013 00).

MALFUNCTION

Compression leakage from valve seat.

CORRECTIVE ACTION

Replace cylinder head assembly (WP 0024 00).

MALFUNCTION

Improper open or close timing of intake/exhaust valves.

CORRECTIVE ACTION

Adjust valve lash (WP 0025 00).

MALFUNCTION

Poor spray pattern from fuel injection nozzle.

CORRECTIVE ACTION

Check fuel injectors; replace as required (WP 0022 00).

MALFUNCTION

Uneven volume of fuel from fuel injectors.

CORRECTIVE ACTION

Check fuel injection pump assembly and fuel injectors; replace as required (WP 0016 00 and WP 0022 00).

MALFUNCTION

Incorrect oil grade/type (for ambient temperature range).

CORRECTIVE ACTION

Drain oil; fill with correct oil (end item configuration manual).

TROUBLESHOOTING - Continued**SYMPTOM - Continued**

Insufficient engine output with black exhaust smoke - Continued.

MALFUNCTION

Too late timing of fuel injection pump assembly.

CORRECTIVE ACTION

Check fuel injection pump assembly; adjust timing (WP 0016 00).

MALFUNCTION

Internal engine problem.

CORRECTIVE ACTION

Replace engine (end item configuration manual).

SYMPTOM

Excessive white smoke while under load.

MALFUNCTION

Incorrect fuel grade/type (for ambient temperature range).

CORRECTIVE ACTION

Drain fuel system; fill with correct fuel (end item configuration manual).

MALFUNCTION

Water in fuel system.

CORRECTIVE ACTION

1. Drain fuel tank and fuel lines and hoses (WP 0017 00, WP 0020 00, and end item configuration manual).
2. Drain water from fuel filter (end item configuration manual).
3. Fill fuel system with clean dry fuel (end item configuration manual).

MALFUNCTION

Excessive slack in fan V-belt.

CORRECTIVE ACTION

Adjust fan V-belt tension (WP 0012 00).

MALFUNCTION

Clogged exhaust pipe.

CORRECTIVE ACTION

Clean exhaust pipe (end item configuration manual).

MALFUNCTION

Engine used at high temperatures or at high altitude.

CORRECTIVE ACTION

Check output drop and load matching requirements; reduce load as required (end item configuration manual).

TROUBLESHOOTING - Continued**SYMPTOM - Continued**

Excessive white smoke while under load - Continued.

MALFUNCTION

Clogged air filter.

CORRECTIVE ACTION

Clean/replace air filter (end item configuration manual).

MALFUNCTION

Defective thermostat.

CORRECTIVE ACTION

Check thermostat; replace as required (WP 0013 00).

MALFUNCTION

Internal engine problem.

CORRECTIVE ACTION

Replace engine (end item configuration manual).

MALFUNCTION

Improper open or close timing of intake/exhaust valves.

CORRECTIVE ACTION

Adjust valve lash (WP 0025 00).

MALFUNCTION

Worn turbocharger assembly bearing.

CORRECTIVE ACTION

Inspect turbocharger assembly bearing; replace as required (WP 0028 00).

MALFUNCTION

Poor spray pattern from fuel injection nozzle.

CORRECTIVE ACTION

Check fuel injectors; adjust as required (WP 0022 00).

MALFUNCTION

Uneven volume of fuel from fuel injectors.

CORRECTIVE ACTION

Check fuel injection pump assembly and fuel injectors; repair/replace as required (WP 0022 00).

MALFUNCTION

Too late timing of fuel injection pump assembly.

CORRECTIVE ACTION

Check fuel injection pump assembly; adjust timing (WP 0016 00).

TROUBLESHOOTING - Continued**SYMPTOM - Continued**

Excessive white smoke while under load - Continued.

MALFUNCTION

Excessive cooling effect of radiator.

CORRECTIVE ACTION

Check thermostat; replace as required (WP 0013 00).

MALFUNCTION

Clogged or deformed oil return line to turbocharger.

CORRECTIVE ACTION

Repair/replace oil line (WP 0027 00).

SYMPTOM

Excessive black smoke while under load.

MALFUNCTION

Clogged air filter.

CORRECTIVE ACTION

Clean/replace air filter (end item configuration manual).

MALFUNCTION

Fouled turbocharger assembly.

CORRECTIVE ACTION

Inspect turbocharger assembly; clean as required (WP 0028 00).

MALFUNCTION

Incorrect fuel grade/type (for ambient temperature range).

CORRECTIVE ACTION

Drain fuel system; fill with correct fuel (end item configuration manual).

MALFUNCTION

Clogged exhaust pipe.

CORRECTIVE ACTION

Clean exhaust pipe (end item configuration manual).

MALFUNCTION

Engine used at high temperatures or at high altitude.

CORRECTIVE ACTION

Check output drop and load matching requirements; reduce load as required (end item configuration manual).

TROUBLESHOOTING - Continued**SYMPTOM - Continued**

Excessive black smoke while under load - Continued.

MALFUNCTION

Turbocharger assembly waste gate malfunction.

CORRECTIVE ACTION

Inspect turbocharger assembly; replace as required (WP 0028 00).

MALFUNCTION

Improper open or close timing of intake/exhaust valves.

CORRECTIVE ACTION

Adjust valve lash (WP 0025 00).

MALFUNCTION

Compression leakage from valve seat.

CORRECTIVE ACTION

Replace cylinder head assembly (WP 0024 00).

MALFUNCTION

Uneven/excessive volume of fuel from fuel injectors.

CORRECTIVE ACTION

Check fuel injectors; replace as required (WP 0022 00).

MALFUNCTION

Internal engine problem.

CORRECTIVE ACTION

Replace engine (end item configuration manual).

MALFUNCTION

Uneven volume of fuel from fuel injectors.

CORRECTIVE ACTION

Check fuel injection pump assembly and fuel injectors; replace as required (WP 0016 00 and WP 0022 00).

MALFUNCTION

Excessive volume of fuel from fuel injectors.

CORRECTIVE ACTION

Check fuel injection pump assembly and fuel injectors; replace as required (WP 0016 00 and WP 0022 00).

MALFUNCTION

Too late timing of fuel injection pump assembly.

CORRECTIVE ACTION

Check fuel injection pump assembly; adjust timing (WP 0016 00).

TROUBLESHOOTING - Continued**SYMPTOM - Continued**

Excessive black smoke while under load - Continued.

MALFUNCTION

Too early timing of fuel injection pump assembly.

CORRECTIVE ACTION

Check fuel injection pump assembly; adjust timing (WP 0016 00).

SYMPTOM

High knocking sound during combustion.

MALFUNCTION

Too early timing of fuel injection pump assembly.

CORRECTIVE ACTION

Check fuel injection pump assembly; adjust timing (WP 0016 00).

SYMPTOM

Abnormal combustion sound.

MALFUNCTION

Improper intake/exhaust valve clearance.

CORRECTIVE ACTION

Adjust valve lash (WP 0025 00).

MALFUNCTION

Compression leakage from valve seat.

CORRECTIVE ACTION

Replace cylinder head assembly (WP 0024 00).

MALFUNCTION

Improper open or close timing of intake/exhaust valves.

CORRECTIVE ACTION

Adjust valve lash (WP 0025 00).

MALFUNCTION

Internal engine problem.

CORRECTIVE ACTION

Replace engine (end item configuration manual).

TROUBLESHOOTING - Continued**SYMPTOM**

Uneven combustion sound.

MALFUNCTION

Incorrect fuel grade/type (for ambient temperature range).

CORRECTIVE ACTION

Drain fuel system; fill with correct fuel (end item configuration manual).

MALFUNCTION

Water in fuel system.

CORRECTIVE ACTION

1. Drain fuel tank and fuel lines and hoses (WP 0017 00, WP 0020 00, and end item configuration manual).
2. Drain water from fuel filter (end item configuration manual).
3. Fill fuel system with clean dry fuel (end item configuration manual).

MALFUNCTION

Clogged exhaust pipe.

CORRECTIVE ACTION

Clean exhaust pipe (end item configuration manual).

MALFUNCTION

Clogged air filter.

CORRECTIVE ACTION

Clean/replace air filter as required (end item configuration manual).

MALFUNCTION

Poor spray pattern from fuel injection nozzle.

CORRECTIVE ACTION

Check fuel injectors; replace as required (WP 0022 00).

MALFUNCTION

Uneven volume of fuel from fuel injectors.

CORRECTIVE ACTION

Check fuel injection pump assembly and fuel injectors; replace as required (WP 0016 00 and WP 0022 00).

TROUBLESHOOTING - Continued**SYMPTOM**

Uneven engine speed (hunting) while idling.

MALFUNCTION

Water in fuel system.

CORRECTIVE ACTION

1. Drain fuel tank and fuel lines and hoses (WP 0017 00, WP 0020 00, and end item configuration manual).
2. Drain water from fuel filter (end item configuration manual).
3. Fill fuel system with clean dry fuel (end item configuration manual).

MALFUNCTION

Defective governor.

CORRECTIVE ACTION

Adjust/replace governor as required (end item configuration manual).

MALFUNCTION

Poor spray pattern from fuel injection nozzle.

CORRECTIVE ACTION

Check fuel injectors; replace as required (WP 0022 00).

MALFUNCTION

Uneven volume of fuel from fuel injectors.

CORRECTIVE ACTION

Check fuel injection pump assembly and fuel injectors; replace as required (WP 0016 00 and WP 0022 00).

MALFUNCTION

Internal engine problem.

CORRECTIVE ACTION

Replace engine (end item configuration manual).

SYMPTOM

Uneven engine speed (hunting) while under load.

MALFUNCTION

Water in fuel system.

CORRECTIVE ACTION

1. Drain fuel tank and fuel lines and hoses (WP 0017 00, WP 0020 00, and end item configuration manual).
2. Drain water from fuel filter (end item configuration manual).
3. Fill fuel system with clean dry fuel (end item configuration manual).

TROUBLESHOOTING - Continued**SYMPTOM - Continued**

Uneven engine speed (hunting) while under load - Continued.

MALFUNCTION

Defective governor.

CORRECTIVE ACTION

Adjust/replace governor as required (end item configuration manual).

MALFUNCTION

Poor spray pattern from fuel injection nozzle.

CORRECTIVE ACTION

Check fuel injectors; replace as required (WP 0022 00).

MALFUNCTION

Uneven volume of fuel from fuel injectors.

CORRECTIVE ACTION

Check fuel injection pump assembly and fuel injectors; replace as required (WP 0016 00 and WP 0022 00).

MALFUNCTION

Internal engine problem.

CORRECTIVE ACTION

Replace engine (end item configuration manual).

SYMPTOM

Excessive engine vibration.

MALFUNCTION

Internal engine problem.

CORRECTIVE ACTION

Replace engine (end item configuration manual).

MALFUNCTION

Defective governor.

CORRECTIVE ACTION

Adjust/replace governor as required (end item configuration manual).

MALFUNCTION

Poor spray pattern from fuel injection nozzle.

CORRECTIVE ACTION

Check fuel injectors; replace as required (WP 0022 00).

TROUBLESHOOTING - Continued**SYMPTOM - Continued**

Excessive engine vibration - Continued.

MALFUNCTION

Uneven volume of fuel from fuel injectors.

CORRECTIVE ACTION

Check fuel injection pump assembly and fuel injectors; replace as required (WP 0016 00 and WP 0022 00).

SYMPTOM

Excessive turbocharger assembly vibration or noise.

MALFUNCTION

Clogged nozzle in turbine wheel chamber.

CORRECTIVE ACTION

Inspect turbocharger assembly; clean as required (WP 0028 00).

MALFUNCTION

Damaged turbocharger assembly bearing, chipped turbine wheel or blower vane, contact between rotating and nonrotating parts, or foreign material in turbine.

CORRECTIVE ACTION

Inspect turbocharger assembly; replace as required (WP 0028 00).

MALFUNCTION

Loosened intake, exhaust, or oil pipe connection with turbocharger assembly.

CORRECTIVE ACTION

Tighten/replace loose parts (WP 0028 00).

SYMPTOM

Slow turbocharger assembly response.

MALFUNCTION

Hard carbon deposit on turbine side.

CORRECTIVE ACTION

Inspect turbocharger assembly; clean as required (WP 0028 00).

SYMPTOM

Difficulty with engine when returning from high speed to low speed.

MALFUNCTION

Defective governor.

CORRECTIVE ACTION

Adjust/replace governor as required (end item configuration manual).

TROUBLESHOOTING - Continued**SYMPTOM**

Excessive fuel consumption.

MALFUNCTION

Engine used at high temperatures or at high altitude.

CORRECTIVE ACTION

Check output drop and load matching requirements; reduce load as required (end item configuration manual).

MALFUNCTION

Compression leakage from valve seat.

CORRECTIVE ACTION

Replace cylinder head assembly (WP 0024 00).

MALFUNCTION

Excessive cooling effect of radiator.

CORRECTIVE ACTION

Check thermostat; replace as required (WP 0013 00).

MALFUNCTION

Too late timing of fuel injection pump assembly.

CORRECTIVE ACTION

Check fuel injection pump assembly; adjust timing (WP 0016 00).

MALFUNCTION

Poor spray pattern from fuel injection nozzle.

CORRECTIVE ACTION

Check fuel injectors; replace as required (WP 0022 00).

MALFUNCTION

Excessive volume of fuel from fuel injectors.

CORRECTIVE ACTION

Check fuel injection pump assembly and fuel injectors; replace as required (WP 0016 00 and WP 0022 00).

SYMPTOM

Excessive oil consumption.

MALFUNCTION

Incorrect oil grade/type (for ambient temperature range).

CORRECTIVE ACTION

Drain oil; fill with correct oil (end item configuration manual).

TROUBLESHOOTING - Continued**SYMPTOM - Continued**

Excessive oil consumption - Continued.

MALFUNCTION

Leakage from oil lines.

CORRECTIVE ACTION

Inspect oil lines; repair as required (WP 0018 00 and WP 0028 00).

MALFUNCTION

Worn intake/exhaust valve guides.

CORRECTIVE ACTION

Replace cylinder head assembly (WP 0024 00).

MALFUNCTION

Internal engine problem.

CORRECTIVE ACTION

Replace engine (end item configuration manual).

MALFUNCTION

Excessive volume of fuel from fuel injectors.

CORRECTIVE ACTION

Check fuel injectors; replace as required (WP 0022 00).

SYMPTOM

Fuel in engine oil.

MALFUNCTION

Internal engine problem.

CORRECTIVE ACTION

Replace engine (end item configuration manual).

SYMPTOM

Oil mixed with coolant.

MALFUNCTION

Leaking cylinder head assembly gasket.

CORRECTIVE ACTION

1. Replace cylinder head assembly gasket (WP 0024 00).
2. Flush cooling system; fill as required (end item configuration manual).
3. Flush lubricating system; fill as required (end item configuration manual).
4. Operate engine and check for coolant in oil or oil in coolant (end item configuration manual).

TROUBLESHOOTING - Continued**SYMPTOM - Continued**

Oil mixed with coolant - Continued.

MALFUNCTION

Internal engine problem.

CORRECTIVE ACTION

Replace engine (end item configuration manual).

SYMPTOM

Low oil pressure.

MALFUNCTION

Insufficient oil level.

CORRECTIVE ACTION

Add oil to proper level (end item configuration manual).

MALFUNCTION

Incorrect oil grade/type (for ambient temperature range).

CORRECTIVE ACTION

Drain oil; fill with correct oil (end item configuration manual).

MALFUNCTION

Leakage from oil lines.

CORRECTIVE ACTION

Check oil lines; repair as required (WP 0018 00 and WP 0028 00).

MALFUNCTION

Internal engine problem.

CORRECTIVE ACTION

Replace engine (end item configuration manual).

MALFUNCTION

Clogged oil filter.

CORRECTIVE ACTION

Replace oil filter (end item configuration manual).

SYMPTOM

Excessive blow-by gas.

MALFUNCTION

Incorrect oil grade/type (for ambient temperature range).

CORRECTIVE ACTION

Drain oil system; fill with correct oil (end item configuration manual).

TROUBLESHOOTING - Continued**SYMPTOM - Continued**

Excessive blow-by gas - Continued.

MALFUNCTION

Clogged oil filter.

CORRECTIVE ACTION

Replace oil filter (end item configuration manual).

MALFUNCTION

Compression leakage from valve seat.

CORRECTIVE ACTION

Replace cylinder head assembly (WP 0024 00).

MALFUNCTION

Worn intake/exhaust valve guides.

CORRECTIVE ACTION

Replace cylinder head assembly (WP 0024 00).

MALFUNCTION

Excessive volume of fuel from fuel injectors.

CORRECTIVE ACTION

Check fuel injectors; replace as required (WP 0022 00).

MALFUNCTION

Internal engine problem.

CORRECTIVE ACTION

Replace engine (end item configuration manual).

SYMPTOM

Engine overheats.

MALFUNCTION

Excessive slack in fan V-belt.

CORRECTIVE ACTION

Adjust fan V-belt tension (WP 0010 00).

MALFUNCTION

Water pump assembly leaking.

CORRECTIVE ACTION

Replace water pump assembly (WP 0012 00).

TROUBLESHOOTING - Continued**SYMPTOM - Continued**

Engine overheats - Continued.

MALFUNCTION

Insufficient coolant level.

CORRECTIVE ACTION

1. Check coolant level; fill with correct coolant (end item configuration manual).
2. Check cooling system for leaks; repair as required (WP 0012 00 and end item configuration manual).

MALFUNCTION

Insufficient cooling effect of radiator.

CORRECTIVE ACTION

1. Check for defective thermostat; replace as required (WP 0013 00).
2. Check for excessive slack in fan V-belt; adjust as required (WP 0010 00).
3. Check radiator for excessive debris on cooling fins; clean as required (end item configuration manual).

MALFUNCTION

Defective thermostat.

CORRECTIVE ACTION

Check thermostat; replace as required (WP 0013 00).

MALFUNCTION

Excessive volume of fuel from fuel injectors.

CORRECTIVE ACTION

Check fuel injectors; replace as required (WP 0022 00).

MALFUNCTION

Engine used at high temperatures or at high altitude.

CORRECTIVE ACTION

Check output drop and load matching requirements; reduce load as required (end item configuration manual).

MALFUNCTION

Leaking cylinder head assembly gasket.

CORRECTIVE ACTION

1. Replace cylinder head assembly gasket (WP 0024 00).
2. Flush cooling system; fill as required (end item configuration manual).
3. Flush lubricating system; fill as required (end item configuration manual).
4. Operate engine and check for coolant in oil or oil in coolant (end item configuration manual).

TROUBLESHOOTING - Continued**SYMPTOM - Continued**

Engine overheats - Continued.

MALFUNCTION

Internal engine problem.

CORRECTIVE ACTION

Replace engine (end item configuration manual).

SYMPTOM

Low coolant temperature.

MALFUNCTION

Defective thermostat.

CORRECTIVE ACTION

Check thermostat; replace as required (WP 0013 00).

SYMPTOM

Air intake pressure drops.

MALFUNCTION

Engine used at high temperatures or at high altitude.

CORRECTIVE ACTION

Check output drop and load matching requirements; reduce load as required (end item configuration manual).

MALFUNCTION

Clogged air filter.

CORRECTIVE ACTION

Clean/replace air filter as required (end item configuration manual).

MALFUNCTION

Improper intake/exhaust valve clearance.

CORRECTIVE ACTION

Adjust valve lash (WP 0025 00).

MALFUNCTION

Compression leakage from valve seat.

CORRECTIVE ACTION

Replace cylinder head assembly (WP 0024 00).

MALFUNCTION

Internal engine problem.

CORRECTIVE ACTION

Replace engine (end item configuration manual).

TROUBLESHOOTING - Continued**SYMPTOM**

Air intake pressure rises.

MALFUNCTION

Excessive volume of fuel from fuel injectors.

CORRECTIVE ACTION

Check fuel injectors; replace as required (WP 0022 00).

SYMPTOM

Exhaust temperature rises.

MALFUNCTION

Insufficient coolant level.

CORRECTIVE ACTION

1. Check coolant level; fill with correct coolant (end item configuration manual).
2. Check cooling system for leaks; repair as required (WP 0012 00 and end item configuration manual).

MALFUNCTION

Excessive slack in fan V-belt.

CORRECTIVE ACTION

Adjust fan V-belt tension (WP 0010 00).

MALFUNCTION

Clogged exhaust pipe.

CORRECTIVE ACTION

Clean exhaust pipe (end item configuration manual).

MALFUNCTION

Insufficient cooling effect of radiator.

CORRECTIVE ACTION

1. Check for defective thermostat; replace as required (WP 0013 00).
2. Check for excessive slack in fan V-belt; adjust as required (WP 0010 00).
3. Check radiator for excessive debris on cooling fins; clean as required (end item configuration manual).

MALFUNCTION

Too late timing of fuel injection pump assembly.

CORRECTIVE ACTION

Check fuel injection pump assembly; adjust timing (WP 0016 00).

TROUBLESHOOTING - Continued**SYMPTOM - Continued**

Exhaust temperature rises - Continued.

MALFUNCTION

Uneven volume of fuel from fuel injectors.

CORRECTIVE ACTION

Check fuel injection pump assembly and fuel injectors; replace as required (WP 0016 00 and WP 0022 00).

MALFUNCTION

Excessive volume of fuel from fuel injectors.

CORRECTIVE ACTION

Check fuel injectors; replace as required (WP 0022 00).

MALFUNCTION

Improper intake/exhaust valve clearance.

CORRECTIVE ACTION

Adjust valve lash (WP 0025 00).

MALFUNCTION

Compression leakage from valve seat.

CORRECTIVE ACTION

Replace cylinder head assembly (WP 0024 00).

MALFUNCTION

Internal engine problem.

CORRECTIVE ACTION

Replace engine (end item configuration manual).

END OF WORK PACKAGE

CHAPTER 3
MAINTENANCE INSTRUCTIONS
FOR
DIESEL ENGINE

CHAPTER 3

MAINTENANCE INSTRUCTIONS FOR DIESEL ENGINE

WORK PACKAGE INDEX

<u>Title</u>	<u>WP Sequence No.</u>
SERVICE UPON RECEIPT	0006 00
PMCS INTRODUCTION	0007 00
PMCS, INCLUDING LUBRICATION INSTRUCTIONS	0008 00
GENERAL MAINTENANCE	0009 00
BATTERY CHARGING ALTERNATOR (24 VDC)	0010 00
FAN, V-PULLEY, AND V-BELT	0011 00
WATER PUMP ASSEMBLY	0012 00
THERMOSTAT, COVER, AND TEMPERATURE SWITCH	0013 00
GEAR CASE ASSEMBLY	0014 00
IDLE GEAR ASSEMBLY	0015 00
FUEL INJECTION PUMP ASSEMBLY	0016 00
FUEL FILTER AND FUEL HOSES	0017 00
OIL COOLER ASSEMBLY AND OIL PRESSURE SWITCH	0018 00
STARTER MOTOR ASSEMBLY	0019 00
FUEL INJECTION LINES AND RETURN HOSE	0020 00
VALVE COVER ASSEMBLY	0021 00
FUEL INJECTORS	0022 00
COMPRESSION TEST	0023 00
CYLINDER HEAD ASSEMBLY	0024 00
LASH VALVE ADJUSTMENT	0025 00
INTAKE MANIFOLD, AIR INLET HOSE, AND AIR HEATERS	0026 00
TURBOCHARGER OIL LINES	0027 00
TURBOCHARGER ASSEMBLY AND EXHAUST MANIFOLD	0028 00
CRANKCASE ASSEMBLY AND DIPSTICK	0029 00
FLYWHEEL ASSEMBLY AND FLYWHEEL HOUSING	0030 00
PREPARATION FOR STORAGE OR SHIPMENT	0031 00
TORQUE LIMITS	0032 00

**FIELD LEVEL
DIESEL ENGINE, 4TNV84T-DFM
NSN 2815-01-538-4237
SERVICE UPON RECEIPT**

INITIAL SETUP:**Tools and Special Tools**

Tool kit, general mechanic
(item 5, WP 0035 00)

Materials/Parts

Breakthrough cleaning solvent
(item 6, WP 0064 00)
Wiping rag (item 5, WP 0064 00)

Personnel Required

One

References

WP 0008 00
DA Form 2404
DA Form 5988-E
DA PAM 738-750
DD Form 1397
DD Form 314
SF 361
SF 368

SERVICE UPON RECEIPT OF MATERIEL

1. Read and follow all instruction on DD Form 1397 attached to conspicuous part of engine.
2. Remove metal strapping, plywood, tapes, seals, and wrappings, if necessary.

WARNING

Cleaning solvent is flammable and toxic to eyes, skin, and respiratory tract. Skin and eye protection are required when working in contact with cleaning solvent. Avoid repeated or prolonged contact. Work in ventilated area only. Failure to comply may result in serious injury or death to personnel.

3. Remove rust preventive compound from coated exterior parts with breakthrough cleaning solvent and wiping rag.
4. Inspect equipment for damage incurred during shipment. If equipment has been damaged, report damage on SF 361, Transportation Discrepancy Report.
5. Check equipment against packing slip to see if shipment is complete. Report all discrepancies in accordance with applicable service instructions (DA PAM 738-750).
6. Check to see if equipment has been modified.

PRELIMINARY CHECKS AND ADJUSTMENT OF EQUIPMENT

1. Inspect equipment for possible damage incurred during shipment. If equipment has been damaged, report damage on SF 368, Product Quality Deficiency Report or SF 361, Transportation Discrepancy Report.
2. Check equipment against packing slip to see if shipment is complete. Report all differences using procedure given in DA PAM 738-750.
3. Perform Preventive Maintenance Checks and Services (PMCS) (WP 0008 00).
4. Schedule next PMCS on DD Form 314, Preventive Maintenance Schedule and Record.
5. Report all deficiencies on DA Form 5988-E, Equipment Inspection and Maintenance Worksheet (automated), or on DA Form 2404, Equipment Inspection and Maintenance Worksheet, if deficiencies appear to involve unsatisfactory design.

END OF WORK PACKAGE

**FIELD LEVEL
DIESEL ENGINE, 4TNV84T-DFM
NSN 2815-01-538-4237
PMCS INTRODUCTION**

INITIAL SETUP:**Tools and Special Tools**

Tool kit, general mechanic
(item 5, WP 0035 00)

Materials/Parts

Breakthrough cleaning solvent
(item 6, WP 0064 00)
Wiping rag (item 5, WP 0064 00)

Personnel Required

One

References

WP 0005 00
WP 0008 00
DA Form 5988-E
DA PAM 738-750

INTRODUCTION

PMCS are performed to keep the engine in operating condition. Inspect the engine within specified intervals so defects are found and corrected or problems are reported before any serious damage or failure occurs. Do the PMCS as shown in the PMCS table (WP 0008 00). Pay attention to WARNINGS and CAUTIONS. A WARNING means someone could be hurt. A CAUTION means equipment could be damaged.

NOTE

Designated intervals are performed under usual operating conditions. PMCS intervals must be performed more frequently when operating under unusual conditions.

1. Always perform preventive maintenance in the same order so it gets to be a habit. Once you have had some practice, you will spot anything wrong in a hurry.
2. Tools included with the engine are to be used when doing the PMCS. Wiping rags are needed to remove dirt or grease.
3. If you find something wrong when performing the PMCS, fix it if you can, using troubleshooting procedures (WP 0005 00) and/or maintenance procedures.
4. If something appears to be wrong and you cannot repair it, write it down on your DA Form 5988-E. If you find something seriously wrong, report it to sustainment level maintenance as soon as possible.
5. Item numbers in column 1 of the PMCS table indicate the PMCS sequence. Use these item numbers for the TM number column on DA Form 5988-E.
6. Information in column 6 of the PMCS table lists conditions that make the equipment not ready/available. Write up items not repaired on DA Form 5988-E for sustainment level maintenance. For further information on how to use these forms, see DA PAM 738-750.

CORROSION PREVENTION AND CONTROL (CPC)

CPC of materiel is a continuing concern. It is important that any corrosion problems with this item be reported so that the problem can be corrected and improvements can be made to prevent the problem in future systems. While corrosion is typically associated with rusting of metals, it can also include deterioration of other materials, such as rubber and plastic. Unusual cracking, softening, swelling, or breaking of these materials may be a corrosion problem. If a corrosion problem is identified, it can be reported using SF 368, Product Quality Deficiency Report. Use of key words such as corrosion, rust, deterioration, or cracking will ensure that the information is identified as a CPC problem. The form should be submitted to the address specified in DA PAM 738-750.

INSPECTION

Look for signs of a problem or trouble. You can feel, smell, hear, or see many problems. Be alert when in or around the engine.

Inspect the engine to see if items are in good condition. Are they correctly assembled, stowed, and secured; excessively worn, leaking, or corroded; or properly lubricated? Correct any problems found or notify sustainment level maintenance. Class III leak(s) require the end item unit to be taken out of service.

There are some common items to check all over the engine. These include the following:

WARNING

Cleaning solvent is flammable and toxic to eyes, skin, and respiratory tract. Skin and eye protection are required when working in contact with cleaning solvent. Avoid repeated or prolonged contact. Work in ventilated area only. Failure to comply may result in serious injury or death to personnel.

1. Dirt, grease, oil, and debris: They only get in the way and may cover up a serious problem. Keep the equipment clean. Clean as you work and as needed. Use breakthrough cleaning solvent and a wiping rag to clean metal surfaces. Use soap and water to clean rubber or plastic material.
2. Bolts, clamps, nuts, and screws: Continuously check for looseness. Look for chipped paint, bare metal, rust, or corrosion around bolt and screw heads and nuts. Tighten them when you find them loose.
3. Welds: Many items on the engine are welded. To check these welds, look for chipped paint, rust, corrosion, or gaps. When these conditions exist, notify sustainment level maintenance on DA Form 5988-E.
4. Electrical wires, connectors, and harnesses: Tighten loose connectors. Look for cracked or broken insulation, bare wires, and broken connectors.
5. Hoses and fluid lines: Check hoses and fluid lines for wear, damage, and leaks. Ensure clamps and fittings are tight.
6. Hinges: Check hinges for security and operation.
7. Data plates: Check data, caution, and warning plates for security and legibility.

PMCS COLUMN DESCRIPTIONS

ITEM NO. - Lists order in which PMCS should be performed; also used as a source of item numbers for the TM number column on DA Form 5988-E when recording results of PMCS.

INTERVAL - Indicates when each check is to be performed.

MANHOUR - Lists approximate time required to perform check.

ITEM TO BE CHECKED OR SERVICED - Lists item to be checked or serviced.

PROCEDURE - Provides brief description of procedure as well as any information required to accomplish each check or service.

EQUIPMENT NOT READY/AVAILABLE IF - Lists condition in which engine should not be operated or accepted.

END OF WORK PACKAGE

**FIELD LEVEL
DIESEL ENGINE, 4TNV84T-DFM
NSN 2815-01-538-4237
PMCS, INCLUDING LUBRICATION INSTRUCTIONS**

INITIAL SETUP:**Tools and Special Tools**

Tool kit, general mechanic's
(item 5, WP 0035 00)

References

WP 0006 00 thru WP 0032 00
End item configuration manual

Personnel Required

One

PMCS

Table 1. Preventive Maintenance Checks and Services.

ITEM NO.	INTERVAL	MAN-HOUR	ITEM TO BE CHECKED OR SERVICED	PROCEDURE	EQUIPMENT NOT READY/ AVAILABLE IF:
1	First 50 hours	0.5	Fan V-belts	<ol style="list-style-type: none"> 1. Check fan V-belts for wear or cracks (WP 0011 00). 2. Check fan V-belt tension and adjust tension if required (WP 0010 00). 	<p>Fan V-belts worn or cracked.</p> <p>Fan V-belts out of adjustment.</p>
2	First 50 hours	0.3	Engine oil and filter	<ol style="list-style-type: none"> 1. Drain lubricating oil. Fill with correct oil (end item configuration manual). 2. Replace oil filter when lubricating oil is changed (end item configuration manual). 	<p>Lubricating oil not changed.</p> <p>Oil filter not changed.</p>
3	300 hours	0.3	Engine oil and filter	<ol style="list-style-type: none"> 1. Drain lubrication oil. Fill with correct oil (end item configuration manual). 2. Replace oil filter when lubrication oil is changed (end item configuration manual). 	<p>Lubricating oil not changed.</p> <p>Oil filter not changed.</p>
4	300 hours	0.7	Engine	Check engine, to include hoses, manifolds, etc., for damage, corrosion, missing parts, and secure mounting (WP 0006 00 thru WP 0032 00).	Engine/parts damaged, corroded, or missing/loose.
5	300 hours	0.3	Starter cables	<ol style="list-style-type: none"> 1. Check starter cable connections for damage, rusted/corrosion, missing parts, and secure mounting (end item configuration manual). 	Cables/parts damaged, rusted/corroded, or missing/loose.

PMCS - Continued

Table 1. Preventive Maintenance Checks and Services - Continued.

ITEM NO.	INTERVAL	MAN-HOUR	ITEM TO BE CHECKED OR SERVICED	PROCEDURE	EQUIPMENT NOT READY/ AVAILABLE IF:
5 - Cont				2. Check cables for fraying, cuts, or nicks (end item configuration manual).	Cables frayed, cut, or nicked.
6	300 hours	0.6	Fuel system	Check fuel system for leaks, secure mounting, and damaged lines or hoses (WP 0017 00, WP 0020 00, WP 0022 00).	Fuel system leaks or defects that would prevent operation.
7	300 hours	0.3	Fuel filter	Check fuel filter for leaks and replace fuel filter element (WP 0017 00).	Fuel filter leaks that would prevent operation; fuel filter not replaced as required.
8	300 hours	0.5	Battery charging alternator (24 Vdc)	Check battery charging alternator for damage, wear, rust/corrosion, missing parts, and secure mounting (WP 0010 00).	Alternator/parts damaged, worn, rusted/corroded, or missing/loose.
9	300 hours	0.5	Fan V-belts	1. Check fan V-belts for wear or cracks (WP 0011 00). 2. Check fan V-belt tension and adjust tension if required (WP 0010 00).	Fan V-belts worn or cracked. Fan V-belts out of adjustment.
10	1,200 hours	1.0	Engine	Clean engine exterior, paying attention to areas that reveal leakage or damage (WP 0009 00).	Engine exterior dirty so leaks or damage cannot be detected.
11	1,500 hours	1.0	Fuel injection nozzles	Check fuel injection nozzle pressure and replace as required (WP 0022 00).	Nozzle pressure out of tolerance.
12	1,500 hours	0.2	Air intake diaphragm	Inspect air intake diaphragm and replace if damaged (WP 0021 00).	Air intake diaphragm damaged.
13	1,500 hours	0.8	Fan V-belts	Replace fan V-belts (WP 0011 00).	Fan V-belts not replaced as required.
14	1,500 hours	3.0	Valve lash	Check/adjust engine valve lash (WP 0025 00).	Valve lash out of adjustment.
15	3,000 hours	4.0	Fuel injectors	Replace fuel injectors (WP 0022 00).	Fuel injectors not replaced as required.

PMCS - Continued**MANDATORY REPLACEMENT PARTS**

There are no mandatory replacement parts required for these PMCS procedures.

LUBRICATION INSTRUCTIONS

External lubrication is not required. Internal lubrication is handled by the end item configuration.

END OF WORK PACKAGE

**FIELD LEVEL
DIESEL ENGINE, 4TNV84T-DFM
NSN 2815-01-538-4237
GENERAL MAINTENANCE**

INITIAL SETUP:**Tools and Special Tools**

Shop equipment, automotive, common,
no. 1 (item 2, WP 0035 00)
Tool kit, general mechanics
(item 5, WP 0035 00)

Personnel Required

One

References

WP 0036 00 thru WP 0064 00
TC 9-237

Materials/Parts

Breakthrough cleaning solvent
(item 6, WP 0064 00)
Crocus cloth (item 1, WP 0064 00)
Marker tags (item 7, WP 0064 00)
Wiping rag (item 5, WP 0064 00)

SCOPE

General maintenance consists of general shop practices and specific methods you must be familiar with to properly maintain the diesel engine. You should read and understand these practices and methods before starting maintenance tasks.

WORK SAFETY**WARNING**

Metal jewelry will conduct electricity. All jewelry can become entangled in rotating components. Remove all jewelry when working on unit. Failure to comply may result in serious injury or death to personnel.

DO NOT wear loose clothing when performing checks, services, and maintenance. Failure to comply may result in serious injury or death to personnel.

High voltage is produced when unit is in operation. Make sure unit is completely shut down and free of any power source before attempting any repair or maintenance on unit. Failure to comply may result in serious injury or death to personnel.

High voltage is produced when unit is in operation. Never attempt to start or maintain unit unless it is properly grounded. Failure to comply may result in serious injury or death to personnel.

Before starting any task, find out how much repair or replacement is needed to fix the equipment as described in this TM. Sometimes the reason for equipment failure can be obvious and complete teardown is not necessary. Disassemble equipment only as far as necessary to repair or replace damaged or broken parts.

All tags and forms attached to the equipment must be checked to learn the reason for removal from service. Also, check Technical Bulletins (TB) for equipment changes and updates.

In some cases a part may be damaged by removal. If the part appears to be good and other parts behind it are not defective, leave it on and continue the procedure.

CLEANING INSTRUCTIONS

Cleaning instructions will be the same for the majority of parts and components which make up the diesel engine.

Maintenance personnel must thoroughly understand the importance of cleaning. Great care and effort are required during cleaning. Dirt and foreign material are a constant threat to satisfactory maintenance. The following should apply to all cleaning, inspection, repair, and assembly operations:

1. Clean all parts before inspection, after repair, and before assembly.
2. Hands should be kept free of any accumulation of grease which can collect dust, dirt, and grit.
3. After cleaning, all parts should be covered or wrapped to protect them from dust and dirt.

Castings, Forgings, and Machined Metal Parts

WARNING

Cleaning solvent is flammable and toxic to eyes, skin, and respiratory tract. Skin and eye protection are required when working in contact with cleaning solvent. Avoid repeated or prolonged contact. Work in ventilated area only. Failure to comply may result in serious injury or death to personnel.

1. Clean inner and outer surfaces with breakthrough cleaning solvent and a wiping rag.
2. Remove grease and accumulated deposits with a stiff bristle brush.

WARNING

Particles blown by compressed air are hazardous. Make sure air stream is directed away from user and other personnel in area. User must wear protective goggles or face shield when using compressed air. Failure to comply may result in serious injury to personnel.

3. Blow out all tapped (threaded) holes with compressed air to remove dirt and cleaning fluids.

Electrical Cables and Rubber Components

CAUTION

Do not wash rubber components and electrical cables with breakthrough cleaning solvents or mineral spirits. Serious damage to or destruction of material may result.

Clean electrical cables and rubber components with water, mild soap solution, and wiping rag.

INSPECTION INSTRUCTIONS

All components and parts must be carefully checked to determine the following:

1. If they are serviceable for reuse.
2. If they can be repaired.
3. If they must be replaced.

INSPECTION INSTRUCTIONS - Continued**Drilled and Tapped (Threaded) Holes**

1. Inspect for wear, distortion, cracks, or any other damage in or around holes.
2. Inspect threaded areas for wear, distortion (stretching), or evidence of cross-threading.
3. Mark all damaged areas for repair or replacement.

Castings, Forgings, and Machined Metal Parts

1. Inspect machined surfaces for nicks, burrs, raised metal, wear, or other damage.
2. Check all inner and outer surfaces for breaks or cracks.
3. Mark all damaged material for repair or replacement.

TAGGING INSTRUCTIONS

When tagging is required during the removal procedure, remove tags during the installation procedure.

REPAIR INSTRUCTIONS**NOTE**

Refer to Source, Maintenance, and Recoverability (SMR) codes assigned to support items listed in the RPSTL work packages (WP 0036 00 thru WP 0064 00).

Any repair procedure peculiar to a specific part or component is covered in the work package relating to that item. After repair, clean all parts thoroughly to prevent dirt, metal chips, or other foreign material from entering working parts.

Castings, Forgings, and Machined Metal Parts

1. Minor cracked castings or forgings may possibly be repaired. Refer to TC 9-237.

WARNING

Cleaning solvent is flammable and toxic to eyes, skin, and respiratory tract. Skin and eye protection are required when working in contact with cleaning solvent. Avoid repeated or prolonged contact. Work in ventilated area only. Failure to comply may result in serious injury or death to personnel.

2. Repair minor damage to machined surfaces with fine-tooth mil file or crocus cloth dipped in breakthrough cleaning solvent.
3. Machined surfaces which are deeply nicked could affect assembly operation and should be replaced.
4. Minor damage to threaded capscrew holes should be repaired with thread tap of same size to prevent cutting oversize.

END OF WORK PACKAGE

**FIELD LEVEL
DIESEL ENGINE, 4TNV84T-DFM
NSN 2815-01-538-4237
BATTERY CHARGING ALTERNATOR (24 VDC)
REMOVAL, INSPECTION, REPAIR, INSTALLATION, ADJUSTMENT**

INITIAL SETUP:**Tools and Special Tools**

Tool kit, general mechanic's
(item 5, WP 0035 00)

Personnel Required

One

Materials/Parts

Marker tags (item 7, WP 0064 00)

References

End item configuration manual

WARNING

Metal jewelry will conduct electricity. All jewelry can become entangled in rotating components. Remove all jewelry when working on unit. Failure to comply may result in serious injury or death to personnel.

DO NOT wear loose clothing when performing checks, services, and maintenance. Failure to comply may result in serious injury or death to personnel.

High voltage is produced when unit is in operation. Make sure unit is completely shut down and free of any power source before attempting any repair or maintenance on unit. Failure to comply may result in serious injury or death to personnel.

High voltage is produced when unit is in operation. Never attempt to start or maintain unit unless it is properly grounded. Failure to comply may result in serious injury or death to personnel.

REMOVAL

1. Tag and disconnect wire harness (figure 1, item 1) from battery charging alternator (24 Vdc) (figure 1, item 2).
2. Remove bolt (figure 1, item 3), spacer (figure 1, item 4), nut (figure 1, item 5), and washer (figure 1, item 6).
3. Push battery charging alternator (24 Vdc) (figure 1, item 2) toward engine to release and remove V-belt (figure 1, item 7).
4. Support battery charging alternator (24 Vdc) (figure 1, item 2) and remove bolt (figure 1, item 8), spacer (figure 1, item 9), and battery charging alternator (24 Vdc) from gear case assembly (figure 1, item 10).
5. Remove bolt (figure 1, item 11) and bracket (figure 1, item 12) only if damaged.

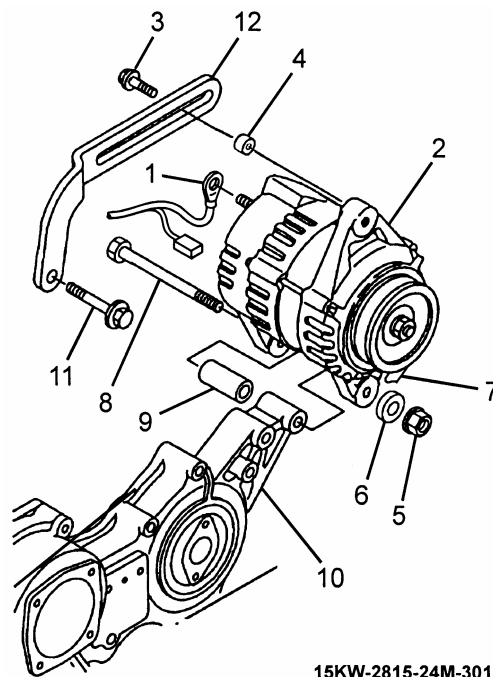

Figure 1. Battery Charging Alternator (24 Vdc).

INSPECTION

1. Inspect all parts for wear, cracks, corrosion, and bent or broken terminals.
2. Inspect all hardware for stripped or damaged threads.
3. Inspect V-belt for cracks, oiliness, or wear.
4. Inspect wire harness for worn or missing insulation, bent or damaged terminals, and corrosion.

REPAIR

Repair of this item is limited to removal and replacement.

INSTALLATION

1. Install bracket (figure 1, item 12) and bolt (figure 1, item 11) if previously removed.
2. Position battery charging alternator (24 Vdc) (figure 1, item 2) and spacer (figure 1, item 9) onto gear case assembly (figure 1, item 10) and install bolt (figure 1, item 8), washer (figure 1, item 6), and nut figure 1, item 5).
3. Install bolt (figure 1, item 3) and spacer (figure 1, item 4). Do not tighten.
4. Position V-belt (figure 1, item 7) over pulley of battery charging alternator (24 Vdc) (figure 1, item 2). Ensure V-belt is properly positioned around other pulleys.
5. Connect wire harness (figure 1, item 1) to battery charging alternator (24 Vdc) (figure 1, item 2). Remove tags.
6. Adjust V-belt (figure 1, item 7) tension per ADJUSTMENT procedure below.

ADJUSTMENT

1. Loosen bolt (figure 1, item 3) and nut (figure 1, item 5) to adjust battery charging alternator (24 Vdc) (figure 1, item 2).
2. Use pry bar (figure 2) and pry battery charging alternator (24 Vdc) (figure 1, item 2) away from engine, adjust V-belt (figure 1, item 7) tension, and tighten hardware.

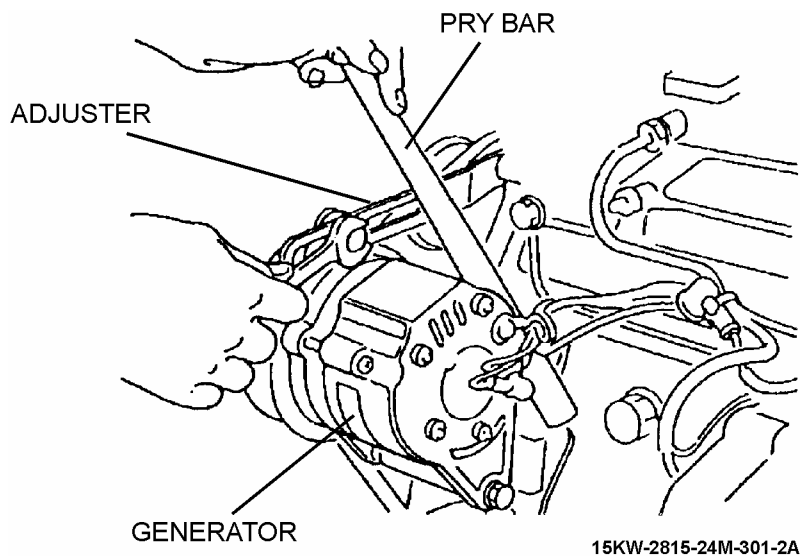

Figure 2. V-Belt Tension Adjustment.

NOTE

V-belt tension can be checked at three different locations (figure 3). Ensure V-belt deflection limits for each V-belt tension check location (table 1, A, B, or C).

3. Check V-belt (figure 1, item 7) tension (figure 3).
4. If V-belt (figure 1, item 7) tension is incorrect (table 1), repeat steps 1 thru 3 above.
5. Run engine for at least 5 minutes (end item configuration manual); then, check V-belt tension (figure 3).

ADJUSTMENT - Continued

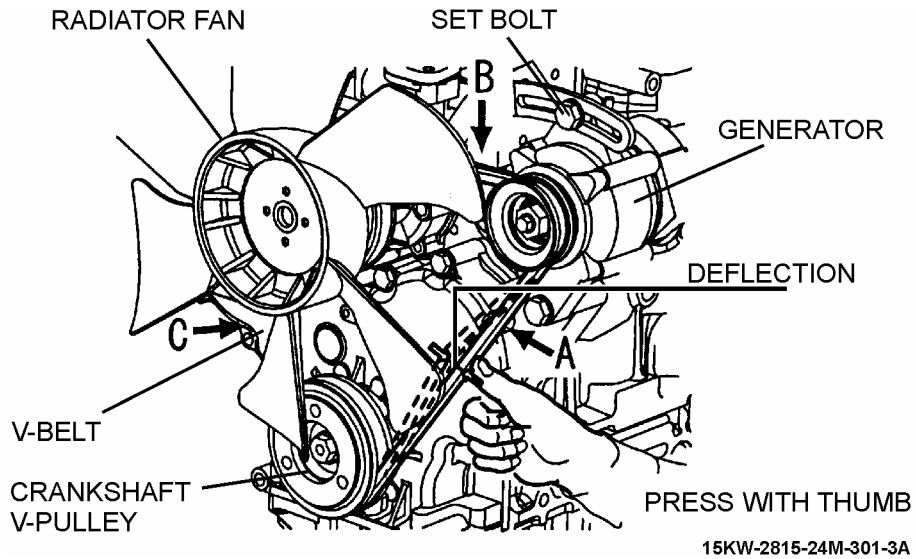

Figure 3. V-Belt Tension Check.

Table 1. V-Belt Deflection Limits.

BELT CONDITION	A	B	C
Used V-belt (used more than 5 minutes)	0.39-0.56 inch (10-14 mm)	0.28-0.39 inch (7-10 mm)	0.35-0.51 inch (9-13 mm)
New V-belt (used less than 5 minutes)	0.31-0.47 inch (8-12 mm)	0.2-0.31 inch (5-8 mm)	0.28-0.43 inch (7-11 mm)

END OF WORK PACKAGE

**FIELD LEVEL
DIESEL ENGINE, 4TNV84T-DFM
NSN 2815-01-538-4237
FAN, V-PULLEY, AND V-BELT
REMOVAL, INSPECTION, REPAIR, INSTALLATION**

INITIAL SETUP:**Tools and Special Tools**

Tool kit, general mechanic
(item 5, WP 0035 00)

References

WP 0010 00

Personnel Required

One

Equipment Condition

V-belt tension relieved (WP 0010 00)

WARNING

Metal jewelry will conduct electricity. All jewelry can become entangled in rotating components. Remove all jewelry when working on unit. Failure to comply may result in serious injury or death to personnel.

DO NOT wear loose clothing when performing checks, services, and maintenance. Failure to comply may result in serious injury or death to personnel.

High voltage is produced when unit is in operation. Make sure unit is completely shut down and free of any power source before attempting any repair or maintenance on unit. Failure to comply may result in serious injury or death to personnel.

High voltage is produced when unit is in operation. Never attempt to start or maintain unit unless it is properly grounded. Failure to comply may result in serious injury or death to personnel.

REMOVAL**NOTE**

V-belt may be removed without removing cooling fan.

1. Release V-belt tension by moving battery charging alternator (24 Vdc) toward engine until V-belt (figure 1, item 1) can be removed from V-pulley (figure 1, item 2).
2. Remove four bolts (figure 1, item 3), cooling fan (figure 1, item 4), spacer (figure 1, item 5), and V-pulley (figure 1, item 6) from cooling water pump (figure 1, item 6).

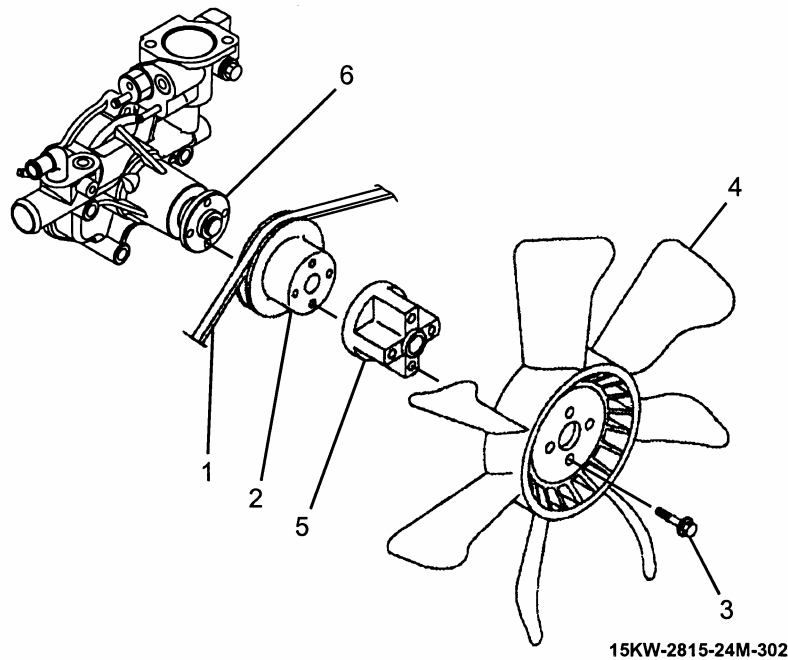

Figure 1. Fan, V-Pulley, and V-Belt.

INSPECTION

1. Inspect all parts for wear, cracks, and corrosion.
2. Inspect all hardware for stripped or damaged threads.
3. Inspect V-belt for cracks, oiliness, or wear.

REPAIR

Repair of this item is limited to removal and replacement.

INSTALLATION**NOTE**

V-belt may be installed with cooling fan installed.

1. Install V-pulley (figure 1, item 2), spacer (figure 1, item 5), cooling fan (figure 1, item 4), and four bolts (figure 1, item 3) onto cooling water pump (figure 1, item 6). Torque bolts to 7.2-8.7 lb-ft (9.8-11.8 Nm).
2. Install V-belt (figure 1, item 1) over V-pulley (figure 1, item 2) and ensure V-belt is properly installed onto other pulleys.
3. Adjust V-belt (figure 1, item 1) tension (WP 0010 00).

END OF WORK PACKAGE

**FIELD LEVEL
DIESEL ENGINE, 4TNV84T-DFM
NSN 2815-01-538-4237
WATER PUMP ASSEMBLY
REMOVAL, INSPECTION, REPAIR, INSTALLATION**

INITIAL SETUP:**Tools and Special Tools**

Tool kit, general mechanic's
(item 5, WP 0035 00)

Personnel Required

One

References

WP 0011 00
WP 0013 00
End item configuration manual

Equipment Condition

Fan, V-pulley, and V-belt removed
(WP 0011 00)
Thermostat, cover, and temperature
switch removed (WP 0013 00)
Coolant hoses removed (end item
configuration manual)

WARNING

Metal jewelry will conduct electricity. All jewelry can become entangled in rotating components. Remove all jewelry when working on unit. Failure to comply may result in serious injury or death to personnel.

DO NOT wear loose clothing when performing checks, services, and maintenance. Failure to comply may result in serious injury or death to personnel.

High voltage is produced when unit is in operation. Make sure unit is completely shut down and free of any power source before attempting any repair or maintenance on unit. Failure to comply may result in serious injury or death to personnel.

High voltage is produced when unit is in operation. Never attempt to start or maintain unit unless it is properly grounded. Failure to comply may result in serious injury or death to personnel.

REMOVAL

1. Squeeze spring clamp (figure 1, item 1) with pliers and slide clamp back onto pipe assembly (figure 1, item 2).
2. Remove pipe assembly (figure 1, item 2) from elbow (figure 1, item 3).
3. Remove elbow (figure 1, item 3) only if damaged.
4. Squeeze spring clamp (figure 1, item 5) with pliers and slide clamp back onto pipe assembly (figure 1, item 6).
5. Remove pipe assembly (figure 1, item 6) from nipple (figure 1, item 7).
6. Squeeze spring clamp (figure 1, item 8) with pliers and slide clamp back onto pipe assembly (figure 1, item 9).
7. Remove pipe assembly (figure 1, item 9) from nipple (figure 1, item 10).
8. Remove three bolts (figure 1, item 11), water pump assembly (figure 1, item 12), gasket (figure 1, item 13), and O-ring (figure 1, item 14).
9. Remove three bolts (figure 1, item 15), adapter (figure 1, item 16), and gasket (figure 1, item 17).
10. If replacing water pump assembly (figure 1, item 12), remove plug (figure 1, item 18), gasket (figure 1, item 19), bolt (figure 1, item 20), and gasket (figure 1, item 21).

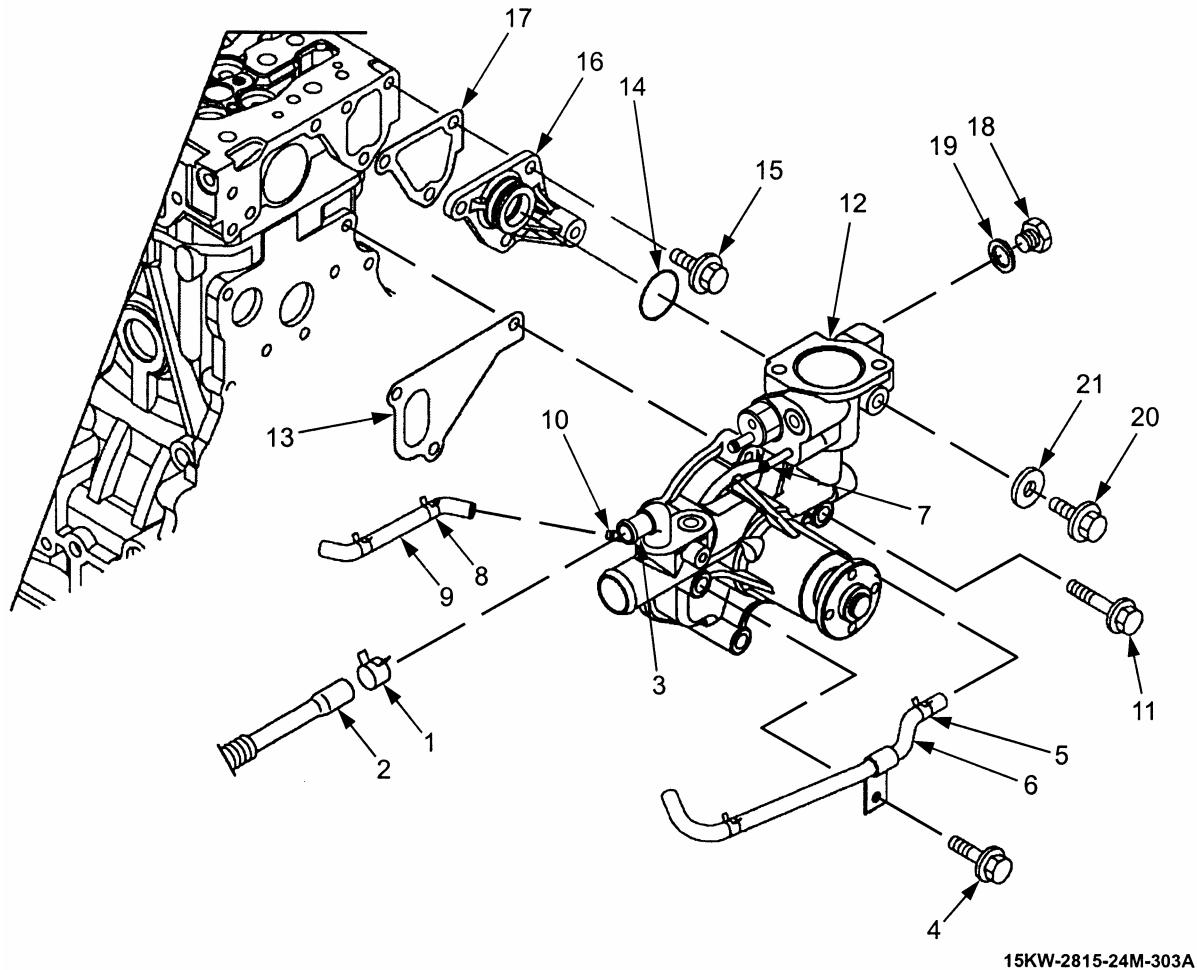
REMOVAL - Continued

15KW-2815-24M-303A

*Figure 1. Water Pump Assembly.***INSPECTION**

1. Inspect all parts for wear, cracks, and corrosion.
2. Inspect all hardware for stripped or damaged threads.
3. Inspect for signs of leakage.

REPAIR

Repair of this item is limited to removal and replacement.

INSTALLATION

1. If replacing water pump assembly (figure 1, item 12), install gasket (figure 1, item 21), bolt (figure 1 item 20), gasket (figure 1, item 19), and plug (figure 1, item 18).
2. Install gasket (figure 1, item 17), adapter (figure 1, item 16), and three bolts (figure 1, item 15). Torque bolts to 16.7-21.0 lb-ft (22.6-28.4 Nm).
3. Install new O-ring (figure 1, item 14), gasket (figure 1, item 13), water pump assembly (figure 1, item 12), and three bolts (figure 1, item 11). Torque bolts to 16.7-21.0 lb-ft (22.6-28.4 Nm).
4. Install pipe assembly (figure 1, item 9) onto nipple (figure 1, item 10) with spring clamp (figure 1, item 8).
5. Install pipe assembly (figure 1, item 6) onto nipple (figure 1, item 7) with spring clamp (figure 1, item 5).
6. Install bolt (figure 1, item 4) to secure pipe assembly (figure 1, item 6) to water pump assembly (figure 1, item 12).
7. Install elbow (figure 1, item 3) if previously removed.
8. Install pipe assembly (figure 1, item 2) onto elbow (figure 1, item 3) with spring clamp (figure 1, item 1).
9. Install coolant hoses (end item configuration manual).
10. Install thermostat, cover, and temperature switch (WP 0013 00).
11. Install fan, V-pulley, and V-belt (WP 0011 00).

END OF WORK PACKAGE

**FIELD LEVEL
DIESEL ENGINE, 4TNV84T-DFM
NSN 2815-01-538-4237
THERMOSTAT, COVER, AND TEMPERATURE SWITCH
REMOVAL, INSPECTION, REPAIR, INSTALLATION**

INITIAL SETUP:**Tools and Special Tools**

Tool kit, general mechanic
(item 5, WP 0035 00)

Personnel Required

One

References

End item configuration manual

Equipment Conditions

Coolant hoses removed (end item
configuration manual)

WARNING

Metal jewelry will conduct electricity. All jewelry can become entangled in rotating components. Remove all jewelry when working on unit. Failure to comply may result in serious injury or death to personnel.

DO NOT wear loose clothing when performing checks, services, and maintenance. Failure to comply may result in serious injury or death to personnel.

High voltage is produced when unit is in operation. Make sure unit is completely shut down and free of any power source before attempting any repair or maintenance on unit. Failure to comply may result in serious injury or death to personnel.

High voltage is produced when unit is in operation. Never attempt to start or maintain unit unless it is properly grounded. Failure to comply may result in serious injury or death to personnel.

REMOVAL

1. Remove two bolts (figure 1, item 1), thermostat cover (figure 1, item 2), gasket (figure 1, item 3), thermostat (figure 1, item 4), and O-ring (figure 1, item 5) from water pump assembly (figure 1, item 6).
2. Remove temperature switch (figure 1, item 7) and gasket (figure 1, item 8) from water pump assembly (figure 1, item 6).

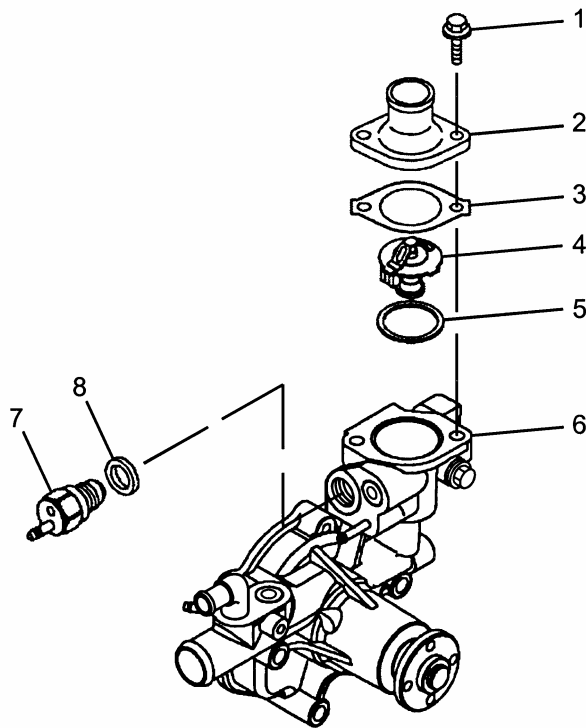

15KW-2815-24M-304

Figure 1. Thermostat, Cover, and Temperature Switch.

INSPECTION

1. Inspect all parts for wear, cracks, and corrosion.
2. Inspect all hardware for stripped or damaged threads.
3. Inspect for signs of leakage.

REPAIR

Repair of this item is limited to removal and replacement.

INSTALLATION

1. Install gasket (figure 1, item 8) and temperature switch (figure 1, item 7) onto water pump assembly (figure 1, item 6).
2. Install O-ring (figure 1, item 5), thermostat (figure 1, item 4), gasket (figure 1, item 3), thermostat cover (figure 1, item 2), and two bolts (figure 1, item 1) onto water pump assembly (figure 1, item 6). Torque bolts to 16.7-21.0 lb-ft (22.6-28.4 Nm).
3. Install coolant hose (end item configuration manual).

END OF WORK PACKAGE

**FIELD LEVEL
DIESEL ENGINE, 4TNV84T-DFM
NSN 2815-01-538-4237
GEAR CASE ASSEMBLY
REMOVAL, INSPECTION, REPAIR, INSTALLATION**

INITIAL SETUP:**Tools and Special Tools**

Tool kit, general mechanics
(item 5, WP 0035 00)

Materials/Parts

Breakthrough cleaning solvent
(item 6, WP 0064 00)
Engine lubricating oil
(item 4, WP 0064 00)
Gasket forming compound
(item 2, WP 0064 00)
Wiping rag (item 5, WP 0064 00)

Personnel Required

One

References

WP 0010 00 and WP 0011 00

Equipment Condition

Battery charging alternator (24 Vdc)
removed (WP 0010 00)
Fan, V-pulley, and V-belt removed
(WP 0011 00)

WARNING

Metal jewelry will conduct electricity. All jewelry can become entangled in rotating components. Remove all jewelry when working on unit. Failure to comply may result in serious injury or death to personnel.

DO NOT wear loose clothing when performing checks, services, and maintenance. Failure to comply may result in serious injury or death to personnel.

High voltage is produced when unit is in operation. Make sure unit is completely shut down and free of any power source before attempting any repair or maintenance on unit. Failure to comply may result in serious injury or death to personnel.

High voltage is produced when unit is in operation. Never attempt to start or maintain unit unless it is properly grounded. Failure to comply may result in serious injury or death to personnel.

REMOVAL

1. Remove bolt (figure 1, item 1), washer (figure 1, item 2), and pulley (figure 1, item 3).
2. Remove oil seal (figure 1, item 4). Discard oil seal.
3. Remove four bolts (figure 1, item 5).
4. Remove 12 bolts (figure 1, item 6).
5. Remove three bolts (figure 1, item 7) and gear case assembly (figure 1, item 8).
6. Remove oil filler cap (figure 1, item 9) and O-ring (figure 1, item 10). Discard O-ring.
7. Remove two bolts (figure 1, item 11), cover (figure 1, item 12), and O-ring (figure 1, item 13).

REMOVAL - Continued

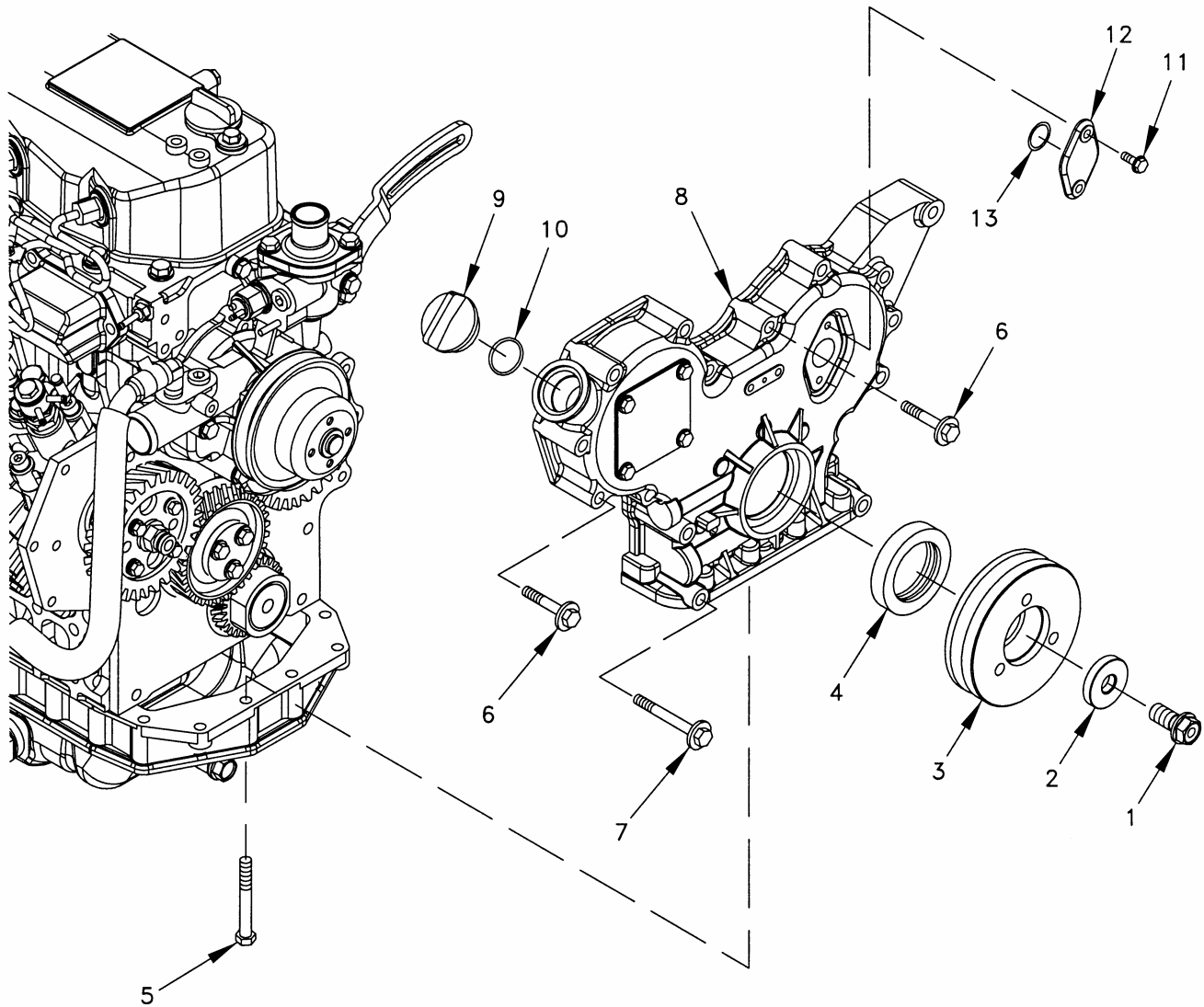

15KW-2815-24M-329C

Figure 1. Gear Case Assembly.

INSPECTION

1. Inspect all parts for damage, wear, cracks, and corrosion.
2. Inspect all hardware for stripped or damaged threads.
3. Check oil drain holes for obstructions.

REPAIR

Repair of this item is limited to removal and replacement.

INSTALLATION

1. Install new O-ring (figure 1, item 13), cover (figure 1, item 12), and two bolts (figure 1, item 11).
2. Install new O-ring (figure 1, item 10) and oil filler cap (figure 1, item 9).

WARNING

Cleaning solvent is flammable and toxic to eyes, skin, and respiratory tract. Skin and eye protection are required when working in contact with cleaning solvent. Avoid repeated or prolonged contact. Work in ventilated area only. Failure to comply may result in serious injury or death to personnel.

3. Thoroughly clean mounting surface of gear case assembly (figure 1, item 8) with breakthrough cleaning solvent and wiping rag.
4. Apply gasket forming compound to mounting surface of gear case assembly (figure 1, item 8).
5. Install gear case assembly (figure 1, item 8) and three bolts (figure 1, item 7).
6. Install 12 bolts (figure 1, item 6).
7. Install four bolts (figure 1, item 5).
8. Lubricate oil seal (figure 1, item 4) with engine lubricating oil and install.
9. Install pulley (figure 1, item 3) using washer (figure 1, item 2) and bolt (figure 1, item 1).
10. Install fan, V-pulley, and V-belt (WP 0011 00).
11. Install battery charging alternator (24 Vdc) (WP 0010 00).

END OF WORK PACKAGE

**FIELD LEVEL
DIESEL ENGINE, 4TNV84T-DFM
NSN 2815-01-538-4237
IDLE GEAR ASSEMBLY
REMOVAL, INSPECTION, REPAIR, INSTALLATION**

INITIAL SETUP:**Tools and Special Tools**

Tool kit, general mechanic's
(item 5, WP 0035 00)

Materials/Parts

Engine lubricating oil (item 4, WP 0064 00)

Personnel Required

One

References

WP 0010 00 thru WP 0012 00
WP 0014 00

Equipment Condition

Battery charging alternator (24 Vdc)
removed (WP 0010 00)
Fan, V-pulley, and V-belt removed
(WP 0011 00)
Gear case assembly removed
(WP 0014 00)

WARNING

Metal jewelry will conduct electricity. All jewelry can become entangled in rotating components. Remove all jewelry when working on unit. Failure to comply may result in serious injury or death to personnel.

DO NOT wear loose clothing when performing checks, services, and maintenance. Failure to comply may result in serious injury or death to personnel.

High voltage is produced when unit is in operation. Make sure unit is completely shut down and free of any power source before attempting any repair or maintenance on unit. Failure to comply may result in serious injury or death to personnel.

High voltage is produced when unit is in operation. Never attempt to start or maintain unit unless it is properly grounded. Failure to comply may result in serious injury or death to personnel.

REMOVAL

1. Measure backlash of idle gear. Backlash for all gears must be 0.002 to 0.005 inches (0.07 to 0.15 mm) with maximum limit of 0.006 inch (0.17 mm).
2. If backlash exceeds limit, replace idle gear as follows:
 - a. Mark all gears at locations A, B, and C for proper orientation during assembly.
 - b. Remove three bolts (figure 1, item 1), idle gear shaft (figure 1, item 2), idle gear bushing (figure 1, item 3), and idle gear (figure 1, item 4).

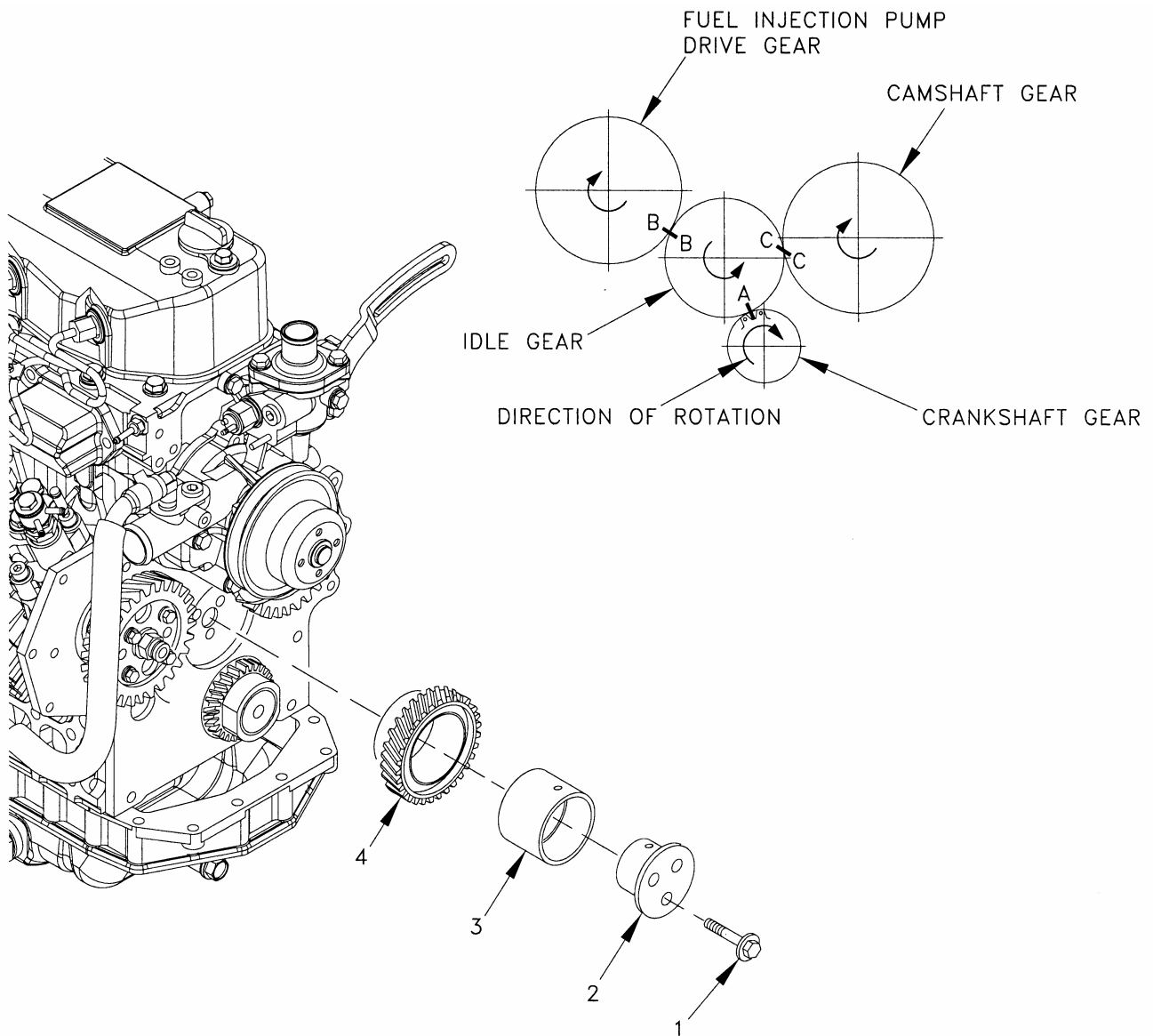

15KW-2815-24M-340A

Figure 1. Idle Gear Assembly.

INSPECTION

1. Measure outside diameter (figure 2) of idle gear shaft (figure 1, item 2) and inside diameter of idle gear bushing (figure 1, item 3).
2. If measurements or clearance limits are exceeded, replace defective part.
3. Inspect all parts for damage, wear, cracks, and corrosion.
4. Inspect all hardware for stripped or damaged threads.
5. Check oil drain holes for obstructions.

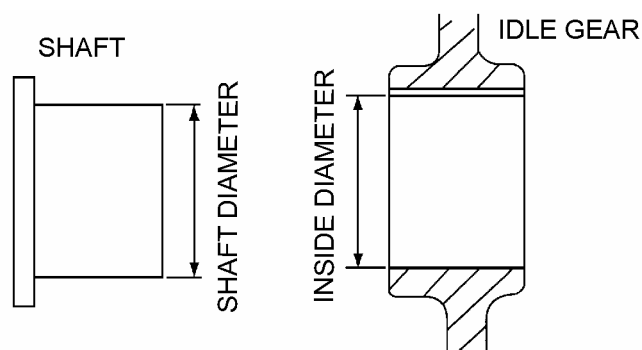

ITEM	STANDARD	LIMIT
SHAFT OUTSIDE DIAMETER	1.8091 TO 1.8090 INCHES (45.950 TO 49.975 mm)	1.8070 INCHES (45.900 mm)
BUSHING INSIDE DIAMETER	1.8110 TO 1.8120 INCHES (46.000 TO 46.025 mm)	1.8139 INCHES (46.075 mm)
CLEARANCE	0.0009 TO 0.0029 INCHES (0.025 TO 0.075 mm)	0.0068 INCHES (0.175 mm)

15KW-2815-24M-345

Figure 2. Idle Gear Shaft and Bushing.

REPAIR

Repair of this item is limited to removal and replacement.

INSTALLATION

1. Lubricate idle gear bushing (figure 1, item 3) and idle gear shaft (figure 1, item 2) with engine lubricating oil.
2. Align all gears per marks A, B, and C and install idle gear (figure 1, item 4), idle gear bushing (figure 1, item 3), idle gear shaft (figure 1, item 2), and three bolts (figure 1, item 1).
3. Install gear case assembly (WP 0014 00).
4. Install water pump assembly (WP 0012 00).
5. Install fan, V-pulley, and V-belt (WP 0011 00).
6. Install battery charging alternator (24 Vdc) (WP 0010 00).

END OF WORK PACKAGE

**FIELD LEVEL
DIESEL ENGINE, 4TNV84T-DFM
NSN 2815-01-538-4237
FUEL INJECTION PUMP ASSEMBLY
REMOVAL, INSPECTION, REPAIR, INSTALLATION**

INITIAL SETUP:**Tools and Special Tools**

Shop equipment, automotive
vehicle (gear puller) (item 3, WP 0035 00)
Tool kit, general mechanic's
(item 5, WP 0035 00)

Materials/Parts

Breakthrough cleaning solvent
(item 6, WP 0064 00)
Engine lubricating oil (item 4, WP 0064 00)
Gasket forming compound (item 2, WP 0064 00)
Petroleum jelly (item 3, WP 0064 00)
Wiping rag (item 5, WP 0064 00)

Personnel Required

One

References

WP 0011 00
WP 0020 00
WP 0026 00
WP 0027 00
End item configuration manual

Equipment Condition

Fan, V-pulley, and V-belt removed
(WP 0011 00)
Fuel injection lines removed
(WP 0020 00)
Intake manifold and air inlet hose
removed (WP 0026 00)
Turbocharger oil line removed
(WP 0027 00)

WARNING

Metal jewelry will conduct electricity. All jewelry can become entangled in rotating components. Remove all jewelry when working on unit. Failure to comply may result in serious injury or death to personnel.

DO NOT wear loose clothing when performing checks, services, and maintenance. Failure to comply may result in serious injury or death to personnel.

High voltage is produced when unit is in operation. Make sure unit is completely shut down and free of any power source before attempting any repair or maintenance on unit. Failure to comply may result in serious injury or death to personnel.

High voltage is produced when unit is in operation. Never attempt to start or maintain unit unless it is properly grounded. Failure to comply may result in serious injury or death to personnel.

REMOVAL**NOTE**

Some fuel may spill when plunger plug is removed from fuel injection pump assembly. Be prepared to contain spilled fuel.

1. Clean top of fuel injection pump assembly (figure 1) and remove plunger plug (figure 1).

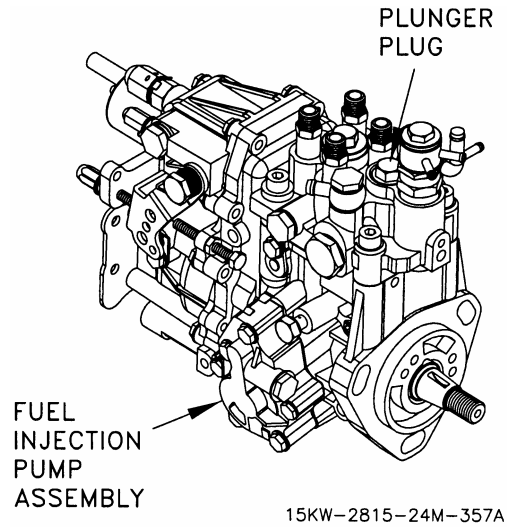

Figure 1. Fuel Injection Pump Assembly Plunger Plug.

REMOVAL - Continued**NOTE**

All references to crankshaft rotation are from water pump end of engine and are performed by turning crankshaft pulley bolt with a socket.

Some fuel may spill when plunger plug is removed from fuel injection pump assembly. Be prepared to contain spilled fuel.

2. Use suitable clean dry probe inserted into fuel injection pump assembly plunger port to determine when fuel injection pump assembly plunger is at bottom of its stroke. Rotate crankshaft Clockwise (CW) until fuel injection pump assembly plunger is at bottom of its stroke. This ensures fuel injection pump assembly shaft will not rotate from spring tension when drive gear is removed.
3. Install fuel injection pump assembly plunger plug (figure 1).
4. Remove four bolts (figure 2, item 1) and cover plate (figure 2, item 2) from gear case assembly (figure 2, item 3).

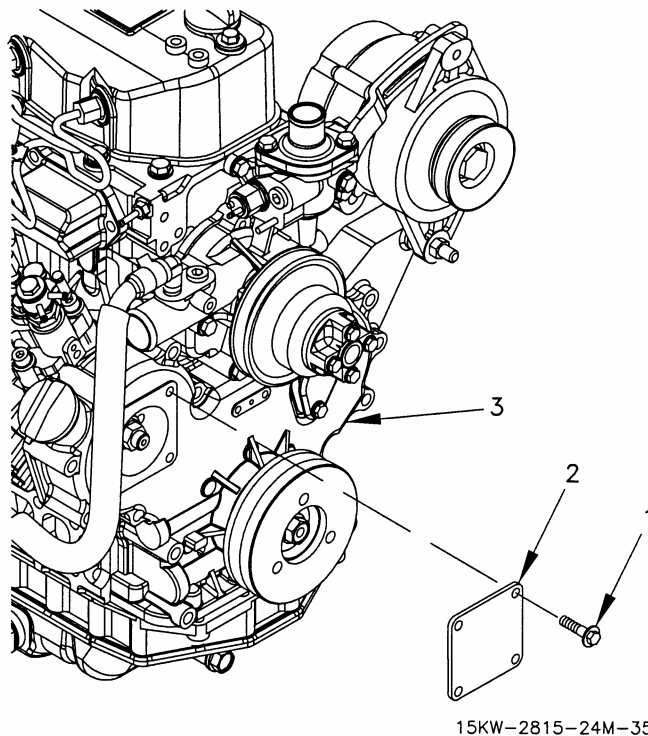
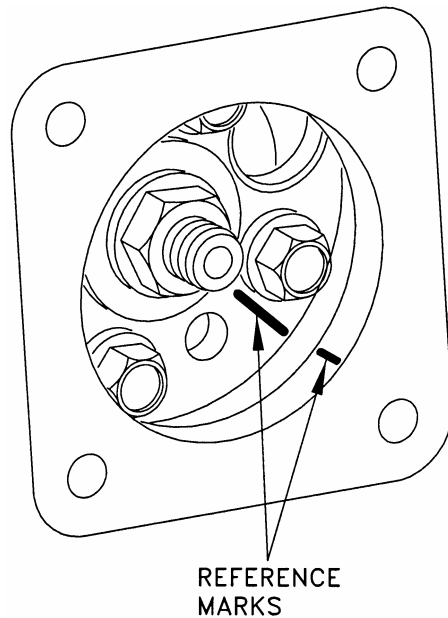

Figure 2. Cover Plate.

REMOVAL - Continued**WARNING**

Cleaning solvent is flammable and toxic to eyes, skin and respiratory tract. Skin and eye protection are required when working in contact with cleaning solvent. Avoid repeated or prolonged contact. Work in ventilated area only. Failure to comply may result in serious injury or death to personnel.

- Clean drive gear and gear case assembly marking locations with breakthrough cleaning solvent and a wiping rag. Mark drive gear and a matching mark on bore of gear case assembly opening (figure 3). Do not remove these marks.



15KW-2815-24M-356

Figure 3. Drive Gear Reference Marks.

CAUTION

Do not loosen or remove four bolts on drive gear or internal fuel injection pump assembly timing will be lost and gear assembly must be replaced.

If nut or lockwasher is dropped into gear case assembly during removal, severe damage to engine may result when operated if hardware is not retrieved. Gear case assembly must be removed to retrieve hardware. Be careful when removing hardware.

NOTE

It may be necessary to hold crankshaft pulley bolt with a socket and breaker bar when loosening drive gear nut.

- Remove center nut (figure 4, item 1) and lockwasher (figure 4, item 2).
- Install a two-bolt-type gear puller or equivalent (figure 4, item 3) onto fuel injection pump assembly drive gear (figure 4, item 4). Gear puller should be perpendicular to drive gear when installed correctly.

REMOVAL □ Continued**CAUTION**

Be careful when pulling drive gear assembly. Outside bolts on drive gear may damage inside of gear housing when drive gear breaks loose.

8. Pull fuel injection pump assembly drive gear (figure 4, item 4) from fuel injection pump assembly drive shaft (figure 4, item 5). Drive gear (figure 4, item 4) will remain inside gear case assembly with gear puller attached.

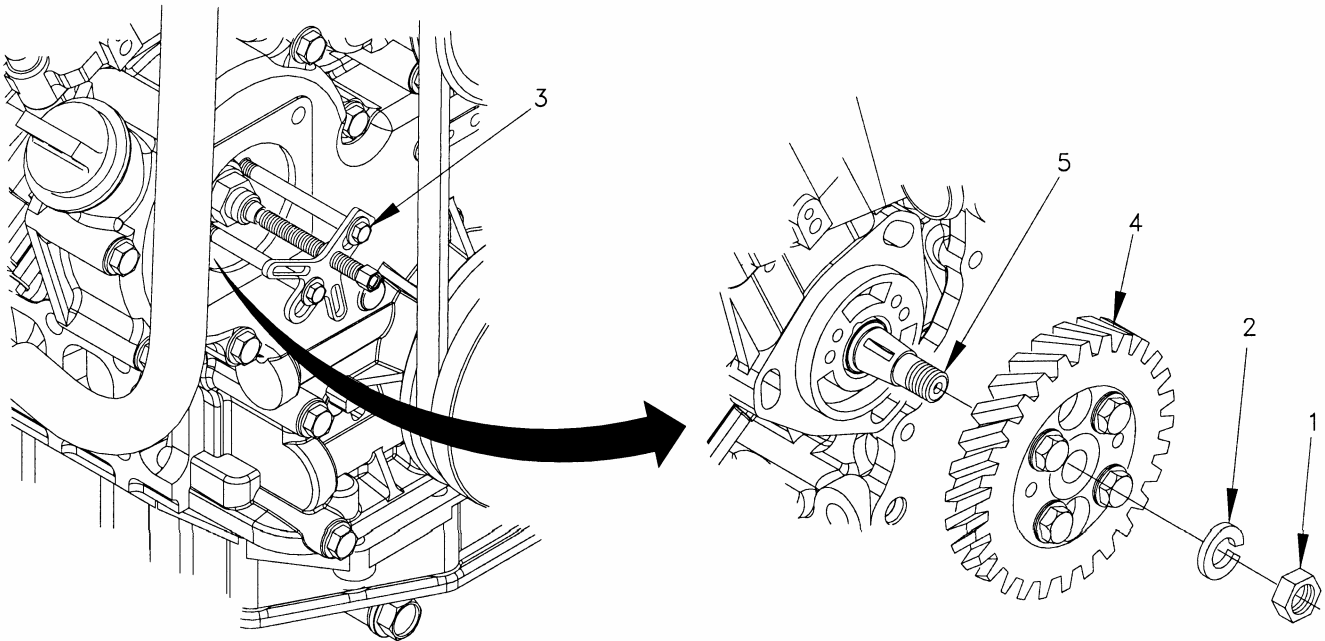

15KW-2815-24M-354

Figure 4. Gear Puller.

NOTE

Tag all hoses before disconnecting to aid during reconnection.

Some fluid (fuel, coolant, or oil) may spill when specific lines or hoses are removed from fuel injection pump assembly. Be prepared to contain spilled fluid.

9. Release two spring clamps (figure 5, item 1) and remove two coolant hoses (figure 5, item 2).
10. Release three spring clamps (figure 5, item 3) and remove three fuel hoses (figure 5, item 4).

REMOVAL - Continued

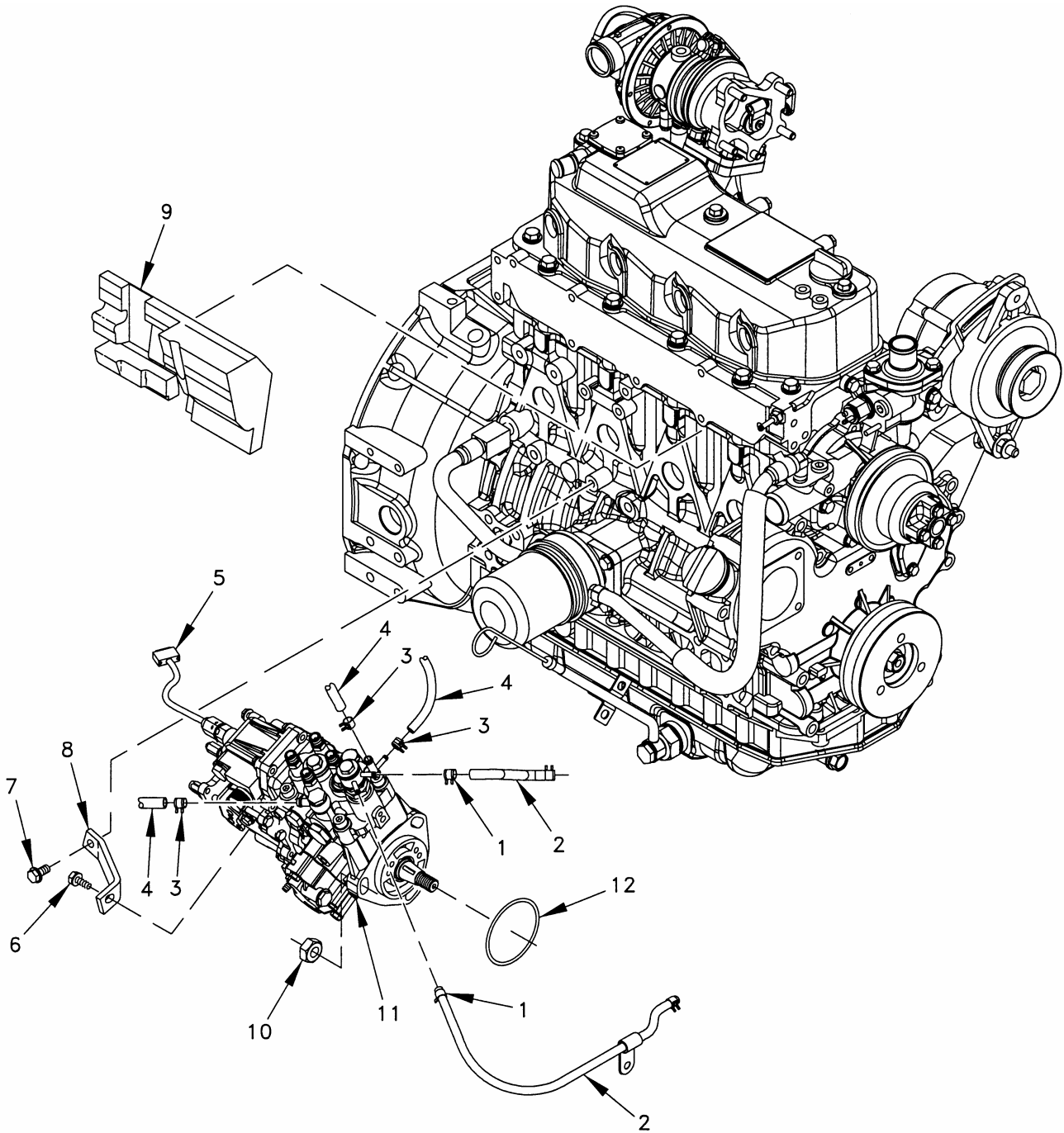

15KW-2815-24M-328B

Figure 5. Fuel Injection Pump Assembly.

REMOVAL - Continued

11. Disconnect electrical connector (figure 5, item 5) from engine harness (end item configuration manual).
12. Remove two bolts (figure 5, items 6 and 7) and bracket (figure 5, item 8)
13. Remove spacer (figure 5, item 9).
14. If original fuel injection pump assembly is to be re-installed, locate timing marks on (figure 6). Use these original alignment marks to position fuel injection pump assembly (set timing) during assembly.

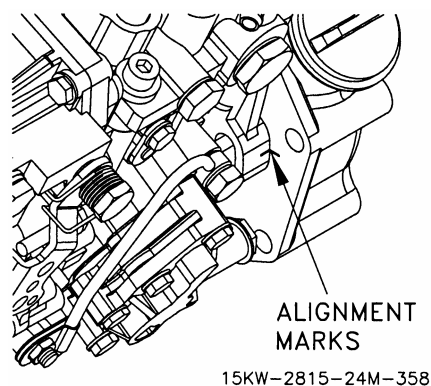

Figure 6. Timing Mark Location.

15. If new fuel injection pump assembly is going to be installed and a timing grid sticker is not in place, install new timing grid sticker (part of new fuel injection pump assembly) onto gear case plate with standard mark of sticker precisely in line with mark on gear case plate (figure 7).
16. If new fuel injection pump assembly is going to be installed and a timing grid sticker is in place, remove this sticker. Locate stamped mark on fuel injection pump assembly mounting flange. Highlight this mark and make a new corresponding mark onto gear case plate. Highlight this new mark also if necessary.
17. Install new timing grid sticker (part of new fuel injection pump assembly) onto gear case plate with standard mark of sticker precisely in line with new mark on gear case plate (figure 7).

REMOVAL - Continued

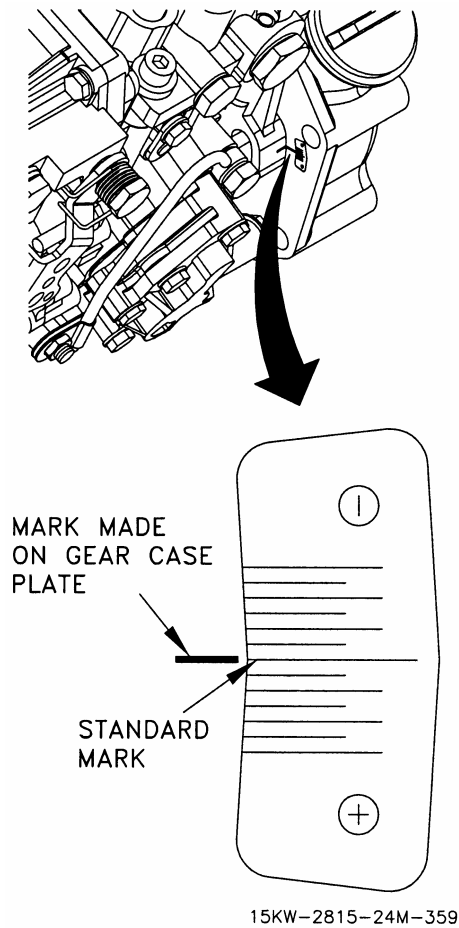

Figure 7. Timing Grid Sticker Location.

18. Remove three nuts (figure 5, item 10), fuel injection pump assembly (figure 5, item 11), and O-ring (figure 5, item 12).
19. Record timing index number found in engraved mark position (figure 8) on defective fuel injection pump assembly (figure 5, item 11).

REMOVAL - Continued

Figure 8. Timing Index Number.

INSPECTION

1. Inspect all parts for wear, cracks, and corrosion.
2. Inspect all hardware for stripped or damaged threads.
3. Inspect for signs of fuel leakage.

REPAIR

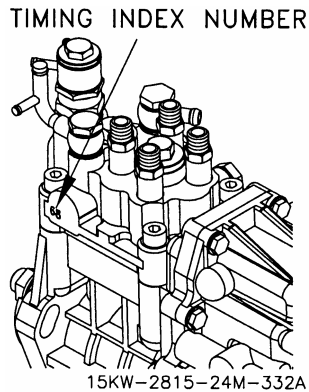
1. Repair of this item is limited to removal and replacement.
2. Repair of fuel injection pump assembly (figure 5, item 11) is not authorized.

INSTALLATION

1. Record timing index number found in engraved mark position (figure 8) on new fuel injection pump assembly (figure 2, item 11).
2. Lubricate O-ring (figure 2, item 12) with petroleum jelly.
3. Install O-ring (figure 2, item 12), fuel injection pump assembly (figure 2, item 11), and three nuts (figure 2, item 10). Tighten nuts just enough to allow fuel injection pump assembly to rotate.
4. Treat timing index numbers (figure 8) recorded in step 1 above and REMOVAL step 19 above as if numbers have decimal points. For example, timing index number 68 would be 6.8.

INSTALLATION - Continued

- Calculate difference between timing index numbers of old fuel injection pump assembly (figure 5, item 11) and new fuel injection pump assembly (figure 5, item 11). Always subtract smaller timing index number from larger timing index number.

NOTE

Each mark on timing index sticker represents a 0.5 degree change in timing referenced from the standard mark.

- If timing index number of new fuel injection pump assembly (figure 5, item 11) is larger than timing index number of old fuel injection pump assembly, fuel injection pump assembly (figure 5, item 11) timing must be advanced (rotated away from engine) (figure 9) by amount determined from step 5 above (figure 10).

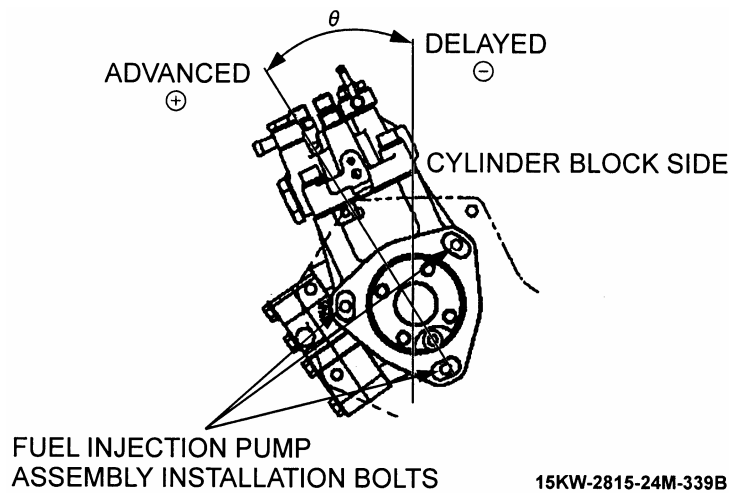

Figure 9. Timing Adjustment Example.

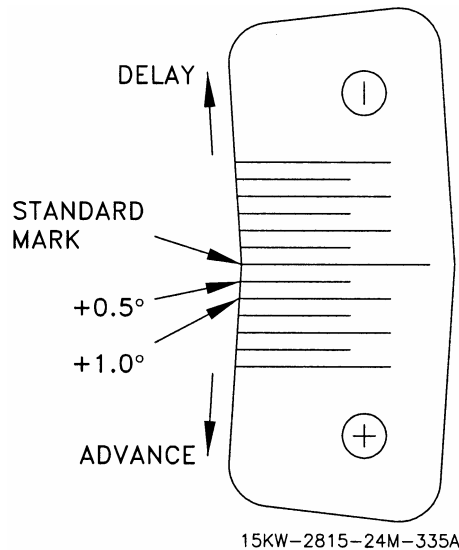

Figure 10. Timing Index Sticker.

INSTALLATION - Continued

7. If timing index number of old fuel injection pump assembly (figure 5, item 11) is larger than timing index number of new fuel injection pump assembly, fuel injection pump assembly timing must be delayed (rotated toward engine) (figure 9) by amount determined from step 5 above (figure 10).
8. For example, if new fuel injection pump assembly timing index number is larger than old fuel injection pump assembly timing index number and resulting difference is 0.5, rotate fuel injection pump assembly (figure 5, item 11) away from engine to advance timing by 0.5 degrees as referenced to standard mark on timing index sticker (figure 10).
9. Hold fuel injection pump assembly at correct timing mark (figure 10) and tighten three nuts (figure 5, item 10).
10. Install spacer (figure 5, item 9).
11. Install intake manifold and air inlet hose (WP 0026 00).
12. Install bracket (figure 5, item 8) with two bolts (figure 5, items 7 and 6).
13. Connect electrical connector (figure 5, item 5) to engine harness (end item configuration manual).
14. Install turbocharger oil line (WP 0027 00).
15. Install three fuel hoses (figure 5, item 4) and three spring clamps (figure 5, item 3).
16. Install two coolant hoses (figure 5, item 2) and two spring clamps (figure 5, item 1).
17. Align drive gear (figure 4, item 4) with key on fuel injection pump assembly shaft (figure 4, item 5) and also match alignment marks on drive gear and bore on gear case assembly opening. Install drive gear onto fuel injection pump assembly shaft.
18. Ensure drive gear (figure 4, item 4) is snug on fuel injection pump assembly shaft (figure 4, item 5) and remove gear puller (figure 4, item 3).

CAUTION

If nut or lockwasher is dropped into gear case assembly during removal, severe damage to engine may result when operated if hardware is not retrieved. Gear case assembly must be removed to retrieve hardware. Be careful when removing hardware.

19. Secure drive gear (figure 4, item 4) with lockwasher (figure 4, item 2) and nut (figure 4, item 1). Hold crankshaft pulley nut with socket and breaker bar and torque nut (figure 4, item 1) to 57.5 to 64.9 lb-ft (78 to 88 Nm).

WARNING

Cleaning solvent is flammable and toxic to eyes, skin and respiratory tract. Skin and eye protection are required when working in contact with cleaning solvent. Avoid repeated or prolonged contact. Work in ventilated area only. Failure to comply may result in serious injury or death to personnel.

20. Remove all traces of old gasket and thoroughly clean mating surfaces of cover plate (figure 2, item 2) and gear case assembly (figure 2, item 3) with breakthrough cleaning solvent and a wiping rag. Apply gasket forming compound to mating surface of cover plate (figure 2, item 2).

INSTALLATION - Continued

21. Install cover plate (figure 2, item 2) onto gear case assembly (figure 2, item 3) with four bolts (figure 2, item 1).
22. Install fuel injection lines (WP 0020 00).
23. Install fan, V-pulley, and V-belt (WP 0011 00).

END OF WORK PACKAGE

**FIELD LEVEL
DIESEL ENGINE, 4TNV84T-DFM
NSN 2815-01-538-4237
FUEL FILTER AND FUEL HOSES
REMOVAL, INSPECTION, REPAIR, INSTALLATION**

INITIAL SETUP:**Tools and Special Tools**

Tool kit, general mechanic's
(item 5, WP 0035 00)

Personnel Required

One

WARNING

Metal jewelry will conduct electricity. All jewelry can become entangled in rotating components. Remove all jewelry when working on unit. Failure to comply may result in serious injury or death to personnel.

DO NOT wear loose clothing when performing checks, services, and maintenance. Failure to comply may result in serious injury or death to personnel.

High voltage is produced when unit is in operation. Make sure unit is completely shut down and free of any power source before attempting any repair or maintenance on unit. Failure to comply may result in serious injury or death to personnel.

High voltage is produced when unit is in operation. Never attempt to start or maintain unit unless it is properly grounded. Failure to comply may result in serious injury or death to personnel.

REMOVAL

1. Remove fuel filter (figure 1, item 1).
2. Squeeze two spring clamps (figure 1, item 2) and slide clamps up onto fuel hose (figure 1, item 3).
3. Remove fuel hose (figure 1, item 3) from filter bracket (figure 1, item 4) and fuel injection pump assembly (figure 1, item 5).
4. Squeeze two spring clamps (figure 1, item 6) and slide clamps up onto fuel hose (figure 1, item 7).
5. Remove fuel hose (figure 1, item 7) from filter bracket (figure 1, item 4) and fuel injection pump assembly (figure 1, item 5).
6. Remove two bolts (figure 1, item 8) and filter bracket (figure 1, item 4).

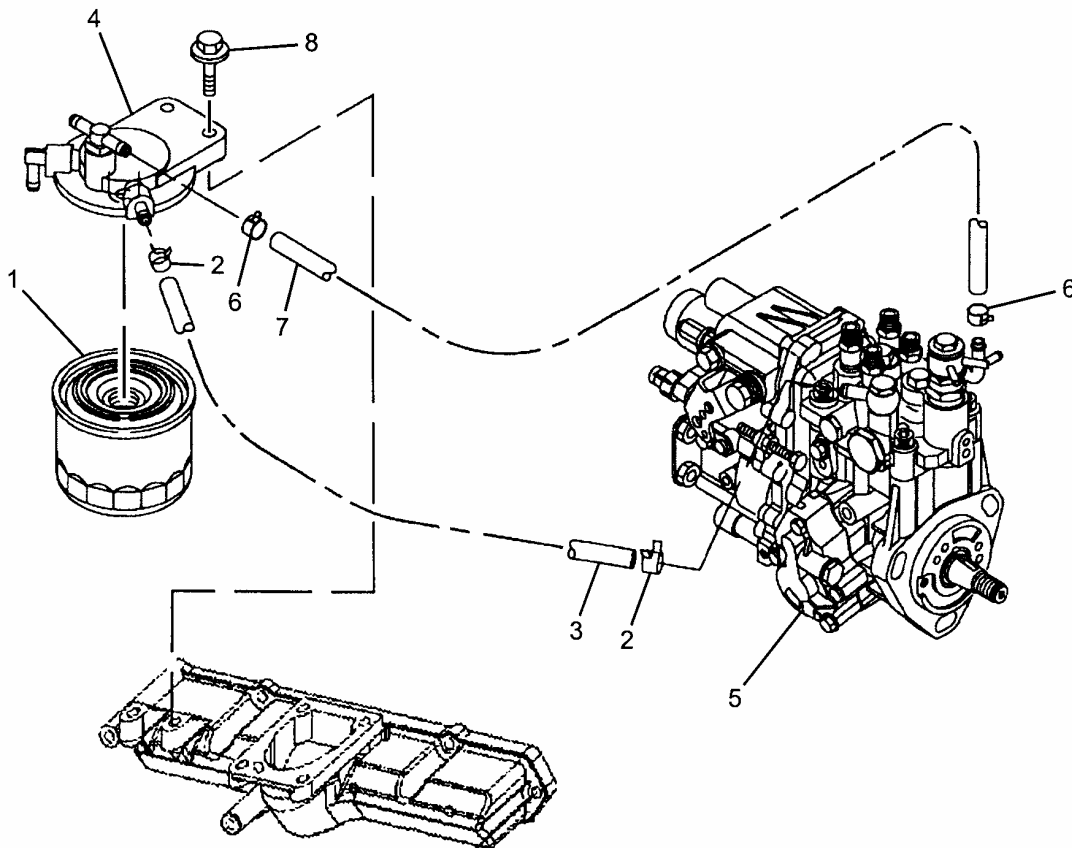

15KW-2815-24M-305

Figure 1. Fuel Filter and Fuel Hoses.

INSPECTION

1. Inspect all parts for wear, cracks, and corrosion.
2. Inspect all hardware for stripped or damaged threads.
3. Inspect for signs of leakage.

REPAIR

Repair of this item is limited to removal and replacement.

INSTALLATION

1. Install filter bracket (figure 1, item 4) and two bolts (figure 1, item 8). Torque bolts to 16.7-21.0 lb-ft (22.6-28.4 Nm).
2. Install fuel hose (figure 1, item 7) onto fuel injection pump assembly (figure 1, item 5) and filter bracket (figure 1, item 4) with two spring clamps (figure 1, item 6).
3. Install fuel hose (figure 1, item 3) onto fuel injection pump assembly (figure 1, item 5) and filter bracket (figure 1, item 4) with two spring clamps (figure 1, item 2).
4. Install fuel filter (figure 1, item 1).

END OF WORK PACKAGE

FIELD LEVEL
DIESEL ENGINE, 4TNV84T-DFM
NSN 2815-01-538-4237
OIL COOLER ASSEMBLY AND OIL PRESSURE SWITCH
REMOVAL, INSPECTION, REPAIR, INSTALLATION

INITIAL SETUP:**Tools and Special Tools**

Tool kit, general mechanic's
(item 5, WP 0035 00)

Personnel Required

One

WARNING

Metal jewelry will conduct electricity. All jewelry can become entangled in rotating components. Remove all jewelry when working on unit. Failure to comply may result in serious injury or death to personnel.

DO NOT wear loose clothing when performing checks, services, and maintenance. Failure to comply may result in serious injury or death to personnel.

High voltage is produced when unit is in operation. Make sure unit is completely shut down and free of any power source before attempting any repair or maintenance on unit. Failure to comply may result in serious injury or death to personnel.

High voltage is produced when unit is in operation. Never attempt to start or maintain unit unless it is properly grounded. Failure to comply may result in serious injury or death to personnel.

REMOVAL

1. Remove oil filter (figure 1, item 1).
2. Squeeze two spring clamps (figure 1, item 2) and slide clamps up onto cooler-out-pipe (figure 1, item 3).
3. Remove cooler-out-pipe (figure 1, item 3) from water pump assembly (figure 1, item 4) and oil cooler assembly (figure 1, item 5).
4. Squeeze two spring clamps (figure 1, item 6) and slide clamps up onto cooler-in-pipe (figure 1, item 7).
5. Remove cooler-in-pipe (figure 1, item 7) from joint (figure 1, item 8) and oil cooler assembly (figure 1, item 5).
6. Remove adapter (figure 1, item 8) and drain plug (figure 1, item 9) if necessary.
7. Remove nut (figure 1, item 10), oil cooler assembly (figure 1, item 5), and stud (figure 1, item 11).
8. Remove three bolts (figure 1, item 12), filter bracket (figure 1, item 13), and gasket (figure 1, item 14).
9. Remove oil pressure switch (figure 1, item 15).

REMOVAL - Continued

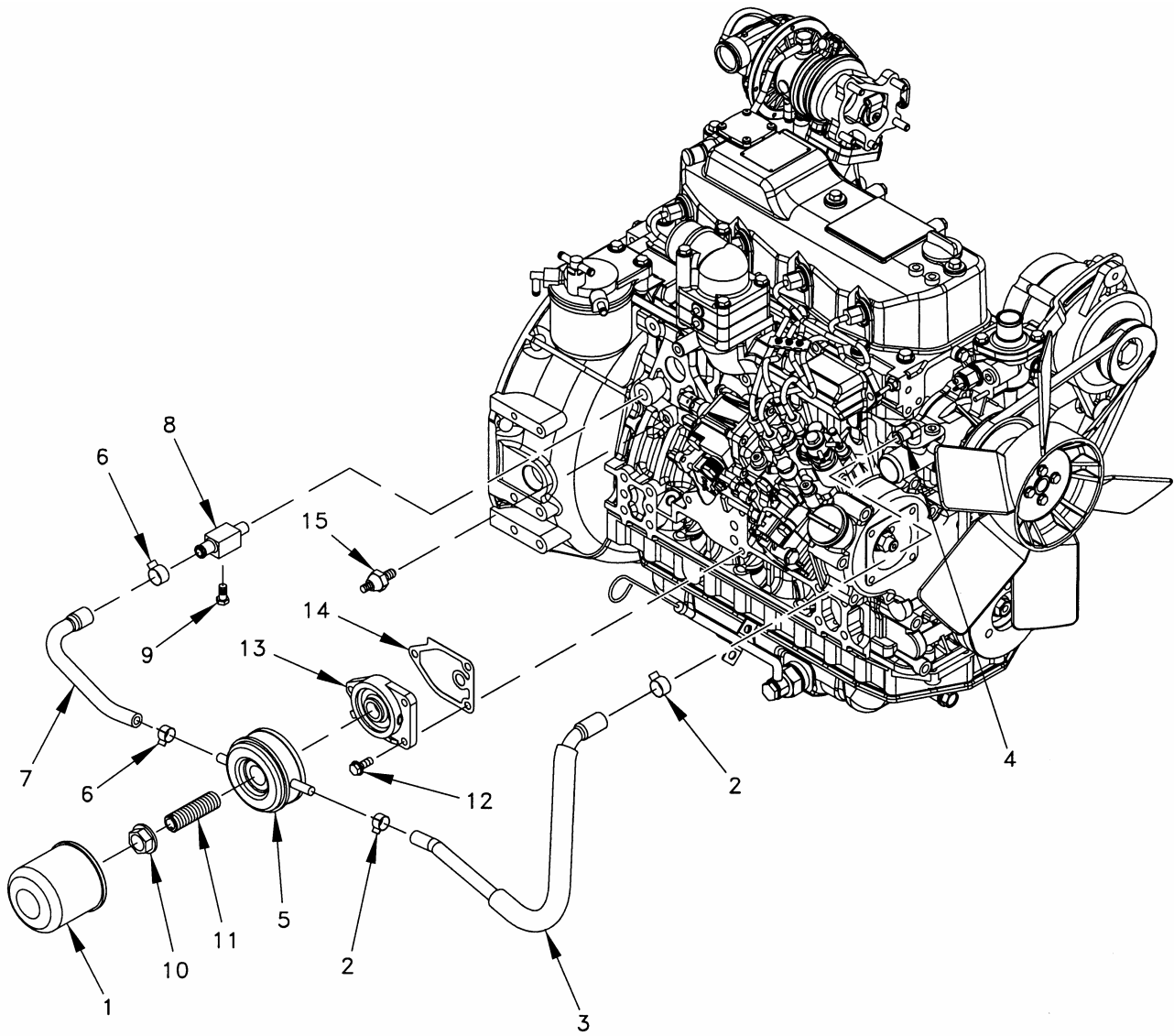

15KW-2815-24M-306A

Figure 1. Oil Cooler Assembly and Oil Pressure Switch.

INSPECTION

1. Inspect all parts for wear, cracks, and corrosion.
2. Inspect all hardware for stripped or damaged threads.
3. Inspect for signs of leakage.

REPAIR

Repair of this item is limited to removal and replacement.

INSTALLATION

1. Install oil pressure switch (figure 1, item 15).
2. Install gasket (figure 1, item 14), filter bracket (figure 1, item 13), and three bolts (figure 1, item 12). Torque bolts to 16.7-21.0 lb-ft (22.6-28.4 Nm).
3. Install stud (figure 1, item 11), oil cooler assembly (figure 1, item 5), and nut (figure 1, item 10).
4. Install drain plug (figure 1, item 9) and adapter (figure 1, item 8).
5. Install cooler-in-pipe (figure 1, item 7) onto adapter (figure 1, item 8) and oil cooler assembly (figure 1, item 5) with two spring clamps (figure 1, item 6).
6. Install cooler-out-pipe (figure 1, item 3) onto oil cooler assembly (5) and water pump assembly (figure 1, item 4) with two spring clamps (figure 1, item 2).
7. Install oil filter (figure 1, item 1).

END OF WORK PACKAGE

**FIELD LEVEL
DIESEL ENGINE, 4TNV84T-DFM
NSN 2815-01-538-4237
STARTER MOTOR ASSEMBLY
REMOVAL, INSPECTION, REPAIR, INSTALLATION**

INITIAL SETUP:**Tools and Special Tools**

Tool kit, general mechanic's
(item 5, WP 0035 00)

Personnel Required

One

Materials/Parts

Marker tags (item 7, WP 0064 00)

WARNING

Metal jewelry will conduct electricity. All jewelry can become entangled in rotating components. Remove all jewelry when working on unit. Failure to comply may result in serious injury or death to personnel.

DO NOT wear loose clothing when performing checks, services, and maintenance. Failure to comply may result in serious injury or death to personnel.

High voltage is produced when unit is in operation. Make sure unit is completely shut down and free of any power source before attempting any repair or maintenance on unit. Failure to comply may result in serious injury or death to personnel.

High voltage is produced when unit is in operation. Never attempt to start or maintain unit unless it is properly grounded. Failure to comply may result in serious injury or death to personnel.

REMOVAL

1. Slide terminal covers (figure 1, item 1) from starter motor terminals.
2. Tag and disconnect wire harness (figure 1, item 2) from starter motor assembly (figure 1, item 3).
3. Remove two bolts (figure 1, item 4) and starter motor assembly (figure 1, item 3) from flywheel housing (figure 1, item 5).

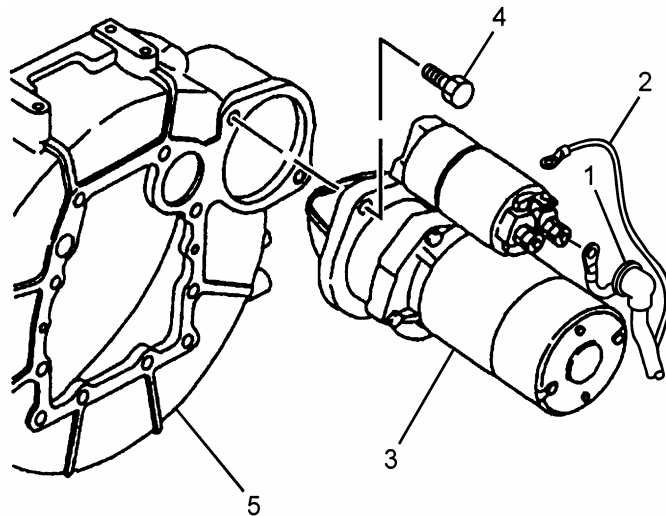

15KW-2815-24M-307A

Figure 1. Starter Motor Assembly.

INSPECTION

1. Inspect all parts for wear, cracks, and corrosion.
2. Inspect all hardware for stripped or damaged threads.
3. Inspect starter motor assembly and wire harness for worn or missing insulation, bent or damaged terminals, and corrosion.

REPAIR

Repair of this item is limited to removal and replacement.

INSTALLATION

1. Carefully position starter motor assembly (figure 1, item 3) onto flywheel assembly housing (figure 1, item 5) and install two bolts (figure 1, item 4). Torque bolts to 57.8 to 72.2 lb-ft (78.8 to 98.0 Nm).
2. Connect wire harness (figure 1, item 2) to starter motor assembly (figure 1, item 3). Remove tags.
3. Position terminal covers (figure 1, item 1) over starter motor terminals.

END OF WORK PACKAGE

**FIELD LEVEL
DIESEL ENGINE, 4TNV84T-DFM
NSN 2815-01-538-4237
FUEL INJECTION LINES AND RETURN HOSE
REMOVAL, INSPECTION, REPAIR, INSTALLATION**

INITIAL SETUP:**Tools and Special Tools**

Tool kit, general mechanic
(item 5, WP 0035 00)

Personnel Required

One

Materials/Parts

Pressure sensitive tape
(item 8, WP 0064 00)

References

WP 0021 00

WARNING

Metal jewelry will conduct electricity. All jewelry can become entangled in rotating components. Remove all jewelry when working on unit. Failure to comply may result in serious injury or death to personnel.

DO NOT wear loose clothing when performing checks, services, and maintenance. Failure to comply may result in serious injury or death to personnel.

High voltage is produced when unit is in operation. Make sure unit is completely shut down and free of any power source before attempting any repair or maintenance on unit. Failure to comply may result in serious injury or death to personnel.

High voltage is produced when unit is in operation. Never attempt to start or maintain unit unless it is properly grounded. Failure to comply may result in serious injury or death to personnel.

REMOVAL

1. Remove three bolts (figure 1, item 1) and retainer (figure 1, item 2).
2. Remove bolt (figure 1, item 3) and retainer (figure 1, item 4).
3. Disconnect four fuel injection lines (figure 1, items 5, 6, 7, and 8) from four fuel injectors (figure 1, item 9) and fuel injection pump assembly (figure 1, item 10). Remove fuel injection lines and cover all fuel ports with pressure sensitive tape to prevent intrusion of foreign matter.
4. Remove valve cover assembly (WP 0021 00).

NOTE

Rocker arm shaft assembly and intake and exhaust valve assemblies not shown for clarity.

5. Remove five banjo bolts (figure 1, item 11), fuel return packings (figure 1, item 12), and fuel return hose assembly (figure 1, item 13) from cylinder head assembly (figure 1, item 14).
6. Squeeze two spring clamps (figure 1, item 15) and slide clamps up onto fuel return hose (figure 1, item 16).
7. Remove fuel return hose (figure 1, item 16) from fuel injection pump assembly (figure 1, item 10) and hose adapter (figure 1, item 17).
8. Remove hose adapter (figure 1, item 17) and seal washer (figure 1, item 18) only if damaged.

REMOVAL - Continued

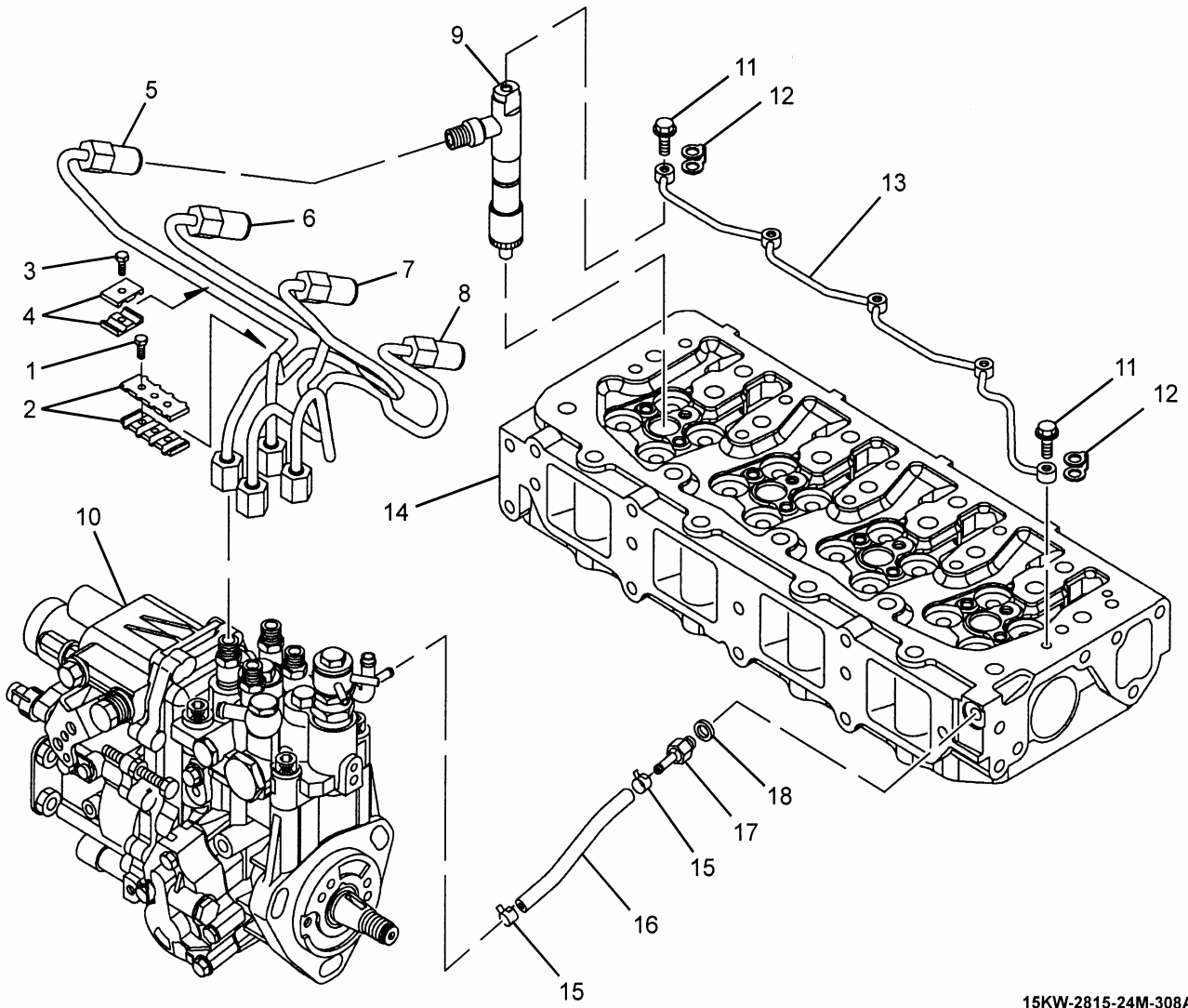

15KW-2815-24M-308A

Figure 1. Fuel Injection Lines and Return Hose.

INSPECTION

1. Inspect all parts for wear, cracks, and corrosion.
2. Inspect all hardware for stripped or damaged threads.
3. Inspect for signs of leakage.

REPAIR

Repair of this item is limited to removal and replacement.

INSTALLATION

1. Install seal washer (figure 1, item 18) and hose adapter (figure 1, item 17).
2. Install fuel return hose (figure 1, item 16) onto fuel injection pump assembly (figure 1, item 10) and hose adapter (figure 1, item 17) with two spring clamps (figure 1, item 15).

NOTE

Rocker shaft assembly and intake and exhaust valve assemblies not shown for clarity.

3. Install fuel return hose (figure 1, item 13), five fuel return packings (figure 1, item 12), and banjo bolts (figure 1, item 11) onto four fuel injectors (figure 1, item 9). Torque banjo bolts to 5.7-7.2 lb-ft (7.8-9.8 Nm).
4. Install valve cover assembly (WP 0021 00).
5. Install four fuel injection lines (figure 1, items 8, 7, 6, and 5) onto fuel injection pump assembly (figure 1, item 10). Do not tighten.
6. Install four fuel injection lines (figure 1, items 8, 7, 6, and 5) onto fuel injectors (figure 1, item 9).
7. Torque both ends of fuel injection lines (figure 1, items 8, 7, 6, and 5) to 21.7-25.3 lb-ft (29.4-34.3 Nm).
8. Install retainer (figure 1, item 4) and bolt (figure 1, item 3).
9. Install retainer (figure 1, item 2) and three bolts (figure 1, item 1).

END OF WORK PACKAGE

FIELD LEVEL
DIESEL ENGINE, 4TNV84T-DFM
NSN 2815-01-538-4237
VALVE COVER ASSEMBLY
REMOVAL, DISASSEMBLY, INSPECTION, REPAIR, ASSEMBLY, INSTALLATION

INITIAL SETUP:**Tools and Special Tools**

Tool kit, general mechanic's
(item 5, WP 0035 00)

Materials/Parts

Gasket forming compound
(item 2, WP 0064 00)

References

WP 0020 00

Equipment Condition

Fuel injection lines removed
(WP 0020 00)

Personnel Required

One

WARNING

Metal jewelry will conduct electricity. All jewelry can become entangled in rotating components. Remove all jewelry when working on unit. Failure to comply may result in serious injury or death to personnel.

DO NOT wear loose clothing when performing checks, services, and maintenance. Failure to comply may result in serious injury or death to personnel.

High voltage is produced when unit is in operation. Make sure unit is completely shut down and free of any power source before attempting any repair or maintenance on unit. Failure to comply may result in serious injury or death to personnel.

High voltage is produced when unit is in operation. Never attempt to start or maintain unit unless it is properly grounded. Failure to comply may result in serious injury or death to personnel.

REMOVAL

1. Disconnect breather hose (figure 1, item 1).
2. Remove three knobs (figure 1, item 2) and O-rings (figure 1, item 3).
3. Gently pry out four seals (figure 1, item 4) from valve cover assembly (figure 1, item 5). Discard seals if deteriorated or damaged.
4. Remove valve cover assembly (figure 1, item 5) and valve cover gasket (figure 1, item 6).

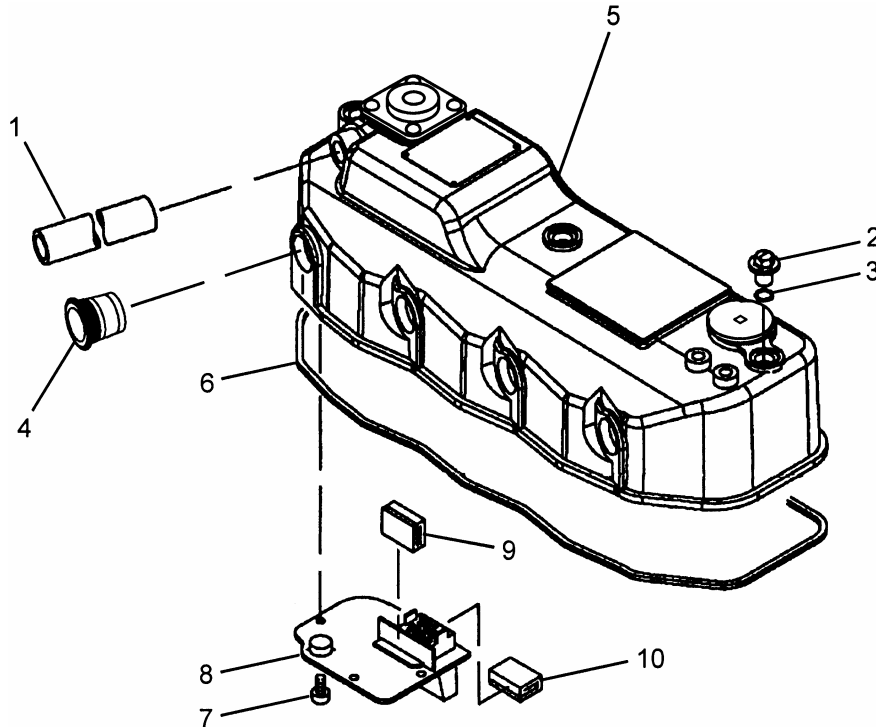

15KW-2815-24M-310B

*Figure 1. Valve Cover Assembly.***DISASSEMBLY**

Remove four screws (figure 1, item 7), baffle plate (figure 1, item 8), and two breather baffles (figure 1, items 9 and 10).

INSPECTION

1. Inspect all parts for wear, cracks, and corrosion.
2. Inspect all hardware for stripped or damaged threads.
3. Inspect for signs of leakage.

REPAIR

Repair of this item is limited to removal and replacement.

ASSEMBLY

1. Install two breather baffles (figure 1, items 10 and 9) onto baffle plate (figure 1, item 8).
2. Apply bead of gasket forming compound to surface of baffle plate (figure 1, item 8) that contacts valve cover assembly (figure 1, item 5)
3. Install baffle plate (figure 1, item 8) and four screws (figure 1, item 7).

INSTALLATION

1. Install valve cover gasket (figure 1, item 6) onto valve cover assembly (figure 1, item 5).
2. Install valve cover assembly (figure 1, item 5), three O-rings (figure 1, item 3), and knobs (figure 1, item 2).
3. Connect breather hose (figure 1, item 1) to valve cover assembly (figure 1, item 5).
4. Install four seals (figure 1, item 4).
5. Install fuel injection lines (WP 0020 00).

END OF WORK PACKAGE

**FIELD LEVEL
DIESEL ENGINE, 4TNV84T-DFM
NSN 2815-01-538-4237
FUEL INJECTORS
REMOVAL, INSPECTION, REPAIR, INSTALLATION**

INITIAL SETUP:**Tools and Special Tools**

Shop equipment, automotive, supplemental
set no. 2 (item 1, WP 0035 00)

Personnel Required

One

Equipment Condition

Fuel injection lines removed
(WP 0020 00)
Valve cover assembly removed
(WP 0021 00)

References

WP 0020 00 and WP 0021 00

WARNING

Metal jewelry will conduct electricity. All jewelry can become entangled in rotating components. Remove all jewelry when working on unit. Failure to comply may result in serious injury or death to personnel.

DO NOT wear loose clothing when performing checks, services, and maintenance. Failure to comply may result in serious injury or death to personnel.

High voltage is produced when unit is in operation. Make sure unit is completely shut down and free of any power source before attempting any repair or maintenance on unit. Failure to comply may result in serious injury or death to personnel.

High voltage is produced when unit is in operation. Never attempt to start or maintain unit unless it is properly grounded. Failure to comply may result in serious injury or death to personnel.

REMOVAL

1. Remove four bolts (figure 1, item 1) and fuel injector valve retainers (figure 1, item 2) from cylinder head assembly (figure 1, item 3).
2. Remove four fuel injectors (figure 1, item 4), nozzle seats (figure 1, item 5), and nozzle protectors (figure 1, item 6) from cylinder head assembly (figure 1, item 3).

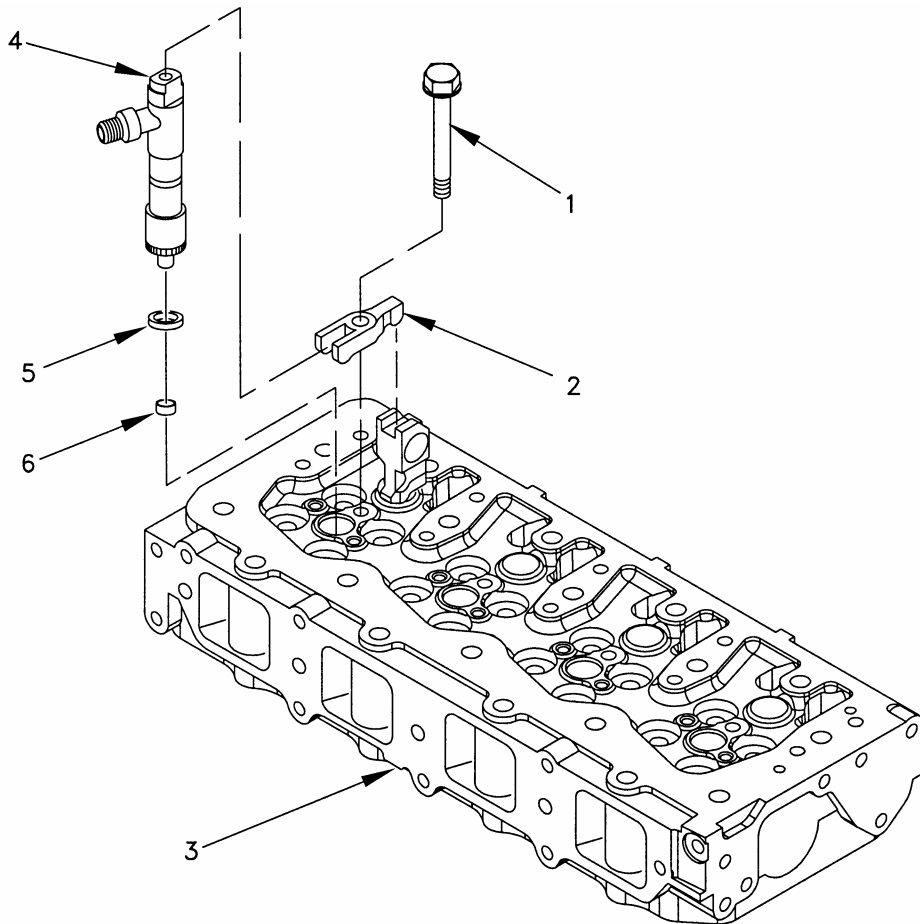

15KW-2815-24M-309C

Figure 1. Fuel Injectors.

INSPECTION

Fuel Injector Nozzle Pressure Test

1. Remove carbon deposits from nozzle hole thoroughly before testing.

WARNING

Injection nozzle produces high pressure fuel spray. User must wear protective goggles or face shield when using injection nozzle tester. Do not direct spray toward bare skin. Failure to comply may result in serious injury to personnel.

2. Connect fuel injector to high pressure pipe of nozzle tester (figure 2).

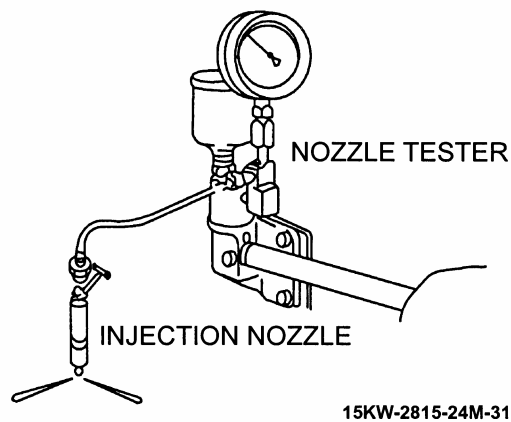

Figure 2. Fuel Injector Test.

3. Operate nozzle tester lever slowly and read pressure at moment when fuel spray from nozzle starts.
4. If measured injection pressure is less than 3,133 to 3,278 psi (21.6 to 22.6 MPa), replace fuel injector figure 1, item 1).

Injector Leak Test

1. Use nozzle tester to check spray pattern and injector nozzle valve when injection pressure is correct.
2. Operate injector two or three times with nozzle tester and gradually increase pressure.
3. Hold pressure for about 5 seconds at just below valve opening pressure of 284 psi (1.96 MPa) and verify fuel does not drip from tip of nozzle.
4. If fuel leaks continuously from top of injector, torque nozzle case nut (figure 1, item 3) to 28.9 to 32.5 lb-ft (39.2 to 44.1 Nm) and retest.
5. If fuel continuously drips from tip of nozzle or top of injector leaks, replace fuel injector (figure 1, item 1).

INSPECTION - Continued**Spray Pattern Inspection**

1. Operate nozzle tester lever once or twice per second and compare spray pattern as follows (figure 3):
 - a. No extreme difference in angle (θ).
 - b. No extreme injection angle difference (α).
 - c. Finely atomized spray.
 - d. Consistent spray volume.

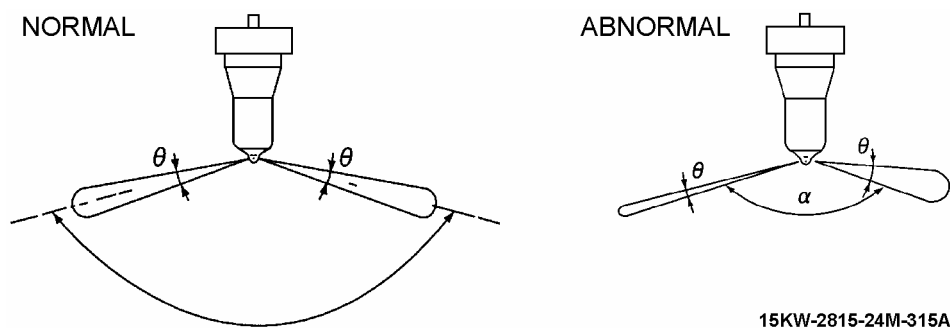

Figure 3. Normal and Abnormal Spray Patterns.

2. If normal spray pattern is not observed, replace fuel injector (figure 1, item 1).

REPAIR

Repair of this item is limited to removal and replacement.

INSTALLATION

1. Install four nozzle protectors (figure 1, item 6), nozzle seats (figure 1, item 5), and fuel injectors (figure 1, item 4) into cylinder head assembly (figure 1, item 3).

NOTE

Ensure bolt indentations on fuel injector retainers are positioned up when installing.

2. Install four fuel injector valve retainers (figure 1, item 2) and bolts (figure 1, item 1) into cylinder head assembly (figure 1, item 3).
3. Install valve cover assembly (WP 0021 00).
4. Install fuel injection lines (WP 0020 00).

END OF WORK PACKAGE

**FIELD LEVEL
DIESEL ENGINE, 4TNV84T-DFM
NSN 2815-01-538-4237
COMPRESSION TEST**

INITIAL SETUP:**Tools and Special Tools**

Shop equipment, automotive, supplemental
set no. 2 (item 1, WP 0035 00)

Personnel Required

One

References

WP 0005 00
WP 0020 00 thru WP 0022 00
End item configuration manual

Equipment Condition

Engine at operating temperature
(end item configuration manual)
Fuel injection lines removed
(WP 0020 00)
Valve cover assembly removed
(WP 0021 00)
Fuel injectors removed (WP 0022 00)

WARNING

Metal jewelry will conduct electricity. All jewelry can become entangled in rotating components. Remove all jewelry when working on unit. Failure to comply may result in serious injury or death to personnel.

DO NOT wear loose clothing when performing checks, services, and maintenance. Failure to comply may result in serious injury or death to personnel.

High voltage is produced when unit is in operation. Make sure unit is completely shut down and free of any power source before attempting any repair or maintenance on unit. Failure to comply may result in serious injury or death to personnel.

High voltage is produced when unit is in operation. Never attempt to start or maintain unit unless it is properly grounded. Failure to comply may result in serious injury or death to personnel.

COMPRESSION TEST**NOTE**

Procedures provide compression test for cylinder no. 1. Other cylinders are typical.

1. Crank engine (end item configuration manual) to make sure all internal components are lubricated.
2. Install nozzle protector (figure 1, item 1), nozzle seat (figure 1, item 2), and adapter (figure 1, item 3) into cylinder head assembly (figure 1, item 4) and secure with fuel injector valve retainers (figure 1, item 5) and bolt (figure 1, item 6).
3. Connect quick disconnect (figure 1, item 7) of compression gage assembly (figure 1, item 8) into adapter (figure 1, item 2).
4. Crank engine (end item configuration manual) until compression gage indication stabilizes.
5. Engine compression must be 440.913 to 411.907 psi (3.04 to 2.84 MPa) with minimum limit of 369.845 to 341.839 psi (2.55 to 2.35 MPa).
6. If engine compression is not within tolerance, refer to troubleshooting procedures to isolate malfunction (WP 0005 00).
7. Repeat steps 2 thru 6 above for remaining cylinders.
8. Install fuel injectors (WP 0022 00).
9. Install valve cover assembly (WP 0021 00).
10. Install fuel injection lines (WP 0020 00).

COMPRESSION TEST - Continued

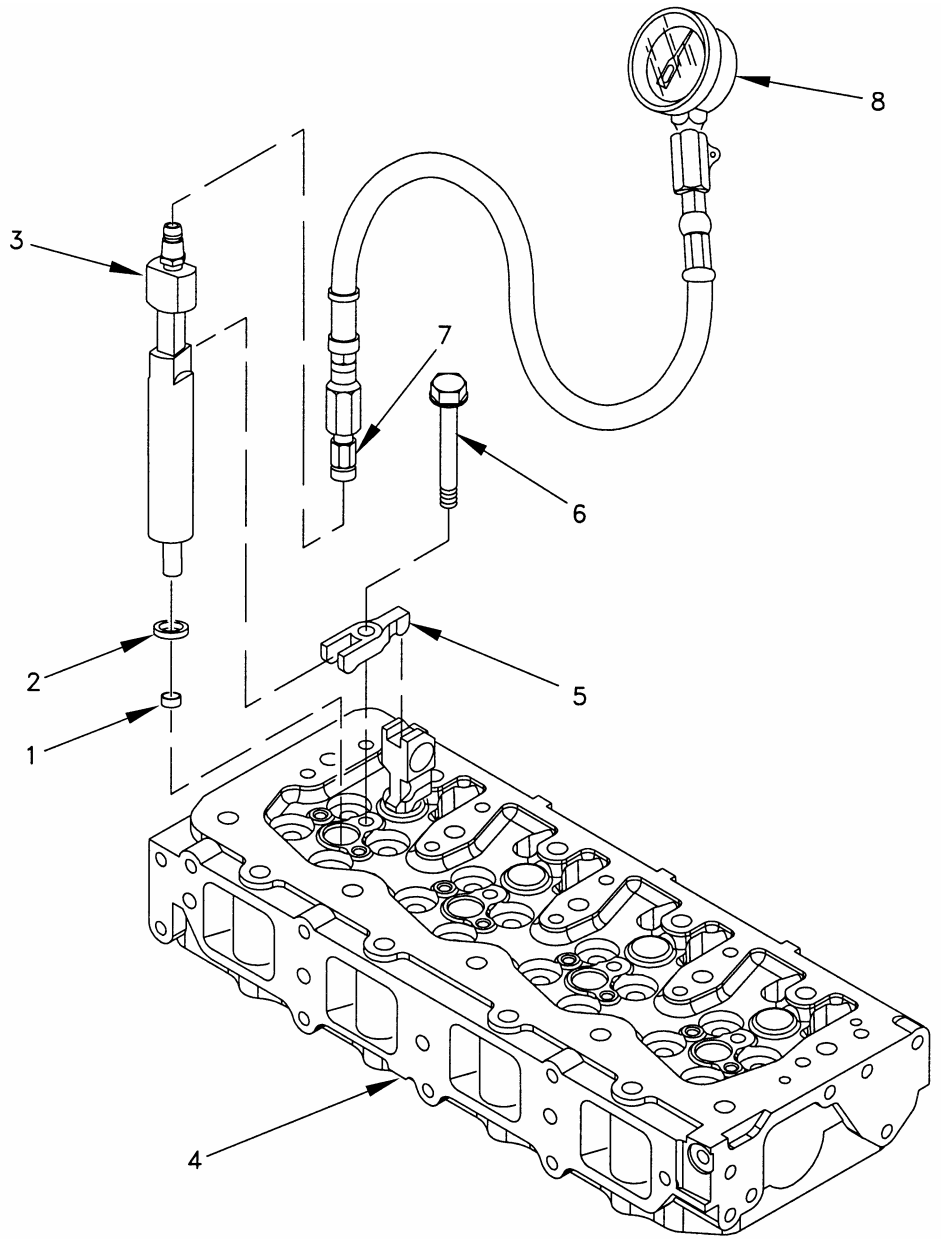

15KW-2815-24M-348B

Figure 1. Compression Test Setup.

END OF WORK PACKAGE

**FIELD LEVEL
DIESEL ENGINE, 4TNV84T-DFM
NSN 2815-01-538-4237
CYLINDER HEAD ASSEMBLY
REMOVAL, INSPECTION, REPAIR, INSTALLATION**

INITIAL SETUP:**Tools and Special Tools**

Tool kit, general mechanic's
(item 5, WP 0035 00)

Materials/Parts

Engine lubricating oil (item 4, WP 0064 00)

Personnel Required

One

References

WP 0012 00
WP 0020 00 and WP 0021 00

References - Continued

WP 0026 00
WP 0028 00

Equipment Condition

Fuel injection lines removed
(WP 0020 00)
Valve cover assembly removed
(WP 0021 00)
Water pump assembly removed
(WP 0012 00)
Intake manifold and air inlet hose
removed (WP 0026 00)
Exhaust manifold removed (WP 0028 00)

WARNING

Metal jewelry will conduct electricity. All jewelry can become entangled in rotating components. Remove all jewelry when working on unit. Failure to comply may result in serious injury or death to personnel.

DO NOT wear loose clothing when performing checks, services, and maintenance. Failure to comply may result in serious injury or death to personnel.

High voltage is produced when unit is in operation. Make sure unit is completely shut down and free of any power source before attempting any repair or maintenance on unit. Failure to comply may result in serious injury or death to personnel.

High voltage is produced when unit is in operation. Never attempt to start or maintain unit unless it is properly grounded. Failure to comply may result in serious injury or death to personnel.

REMOVAL

1. Compress hose clamp (figure 1, item 1) and remove hose (figure 1, item 2) from cylinder head assembly (figure 1, item 3).

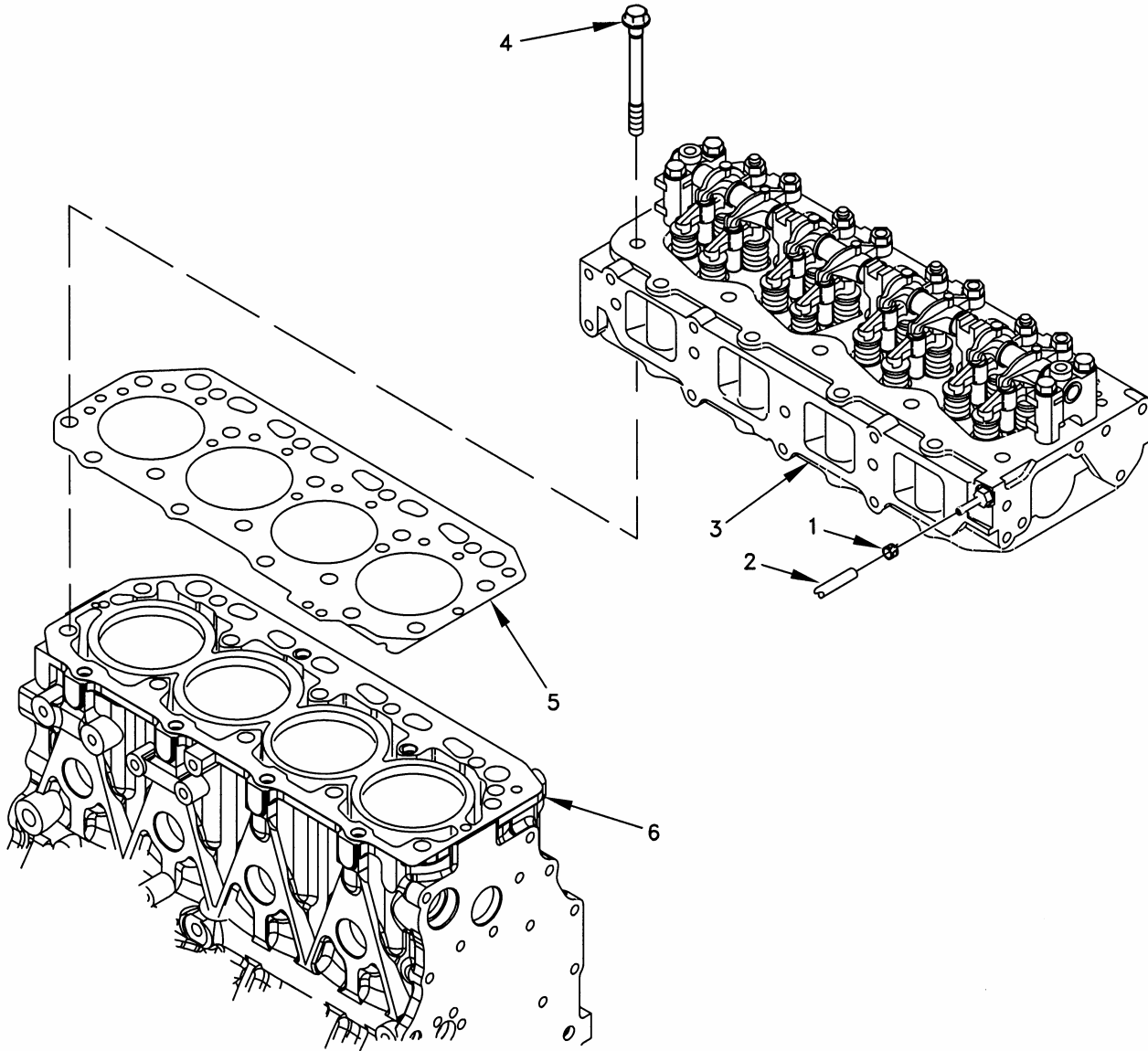

15KW-2815-24M-311C

Figure 1. Cylinder Head Assembly.

REMOVAL - Continued

NOTE

It may be necessary to free cylinder head assembly from cylinder block assembly by tapping with soft-head hammer.

- Loosen 18 bolts (figure 1, item 4) per sequence in figure 2; then, remove bolts in same sequence.

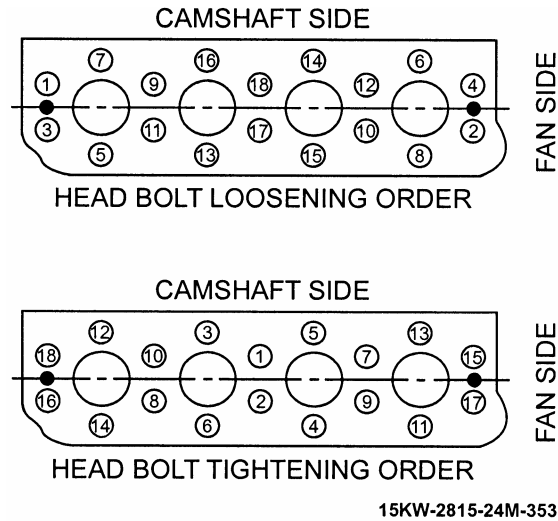

Figure 2. Cylinder Head Bolts.

- Remove cylinder head assembly (figure 1, item 3) and move to clean work location.
- Remove cylinder head gasket (figure 1, item 5) from cylinder block assembly (figure 1, item 6). Discard cylinder head gasket.

INSPECTION

- Inspect all parts for damage, wear, cracks, and corrosion.
- Inspect all hardware for stripped or damaged threads.
- Check oil drain holes for obstructions.

REPAIR

Repair of this item is limited to removal and replacement.

INSTALLATION

1. Install new cylinder head gasket (figure 1, item 5) onto cylinder block assembly (figure 1, item 6).

CAUTION

If alignment pins do not align with cylinder block assembly correctly, cylinder head gasket or cylinder block combustion surface may be damaged.

2. Make sure alignment pins are aligned and carefully install cylinder head assembly (figure 1, item 5) onto cylinder block assembly (figure 1, item 6).
3. Install 18 bolts (figure 1, item 4) and torque to initial torque of 30.31 to 34.60 lb-ft. (41.1 to 46.9 Nm) per sequence in figure 2. Then, torque bolts to 62.91 to 67.19 lb-ft. (85.3 to 91.1 Nm) using same sequence.
4. Compress hose clamp (figure 1, item 1) and install hose (figure 1, item 2) onto cylinder head assembly (figure 1, item 3).
5. Install exhaust manifold (WP 0028 00).
6. Install intake manifold and air inlet hose (WP 0026 00).
7. Install water pump assembly (WP 0012 00).
8. Install valve cover assembly (WP 0021 00).
9. Install fuel injection lines (WP 0020 00).

END OF WORK PACKAGE

**FIELD LEVEL
DIESEL ENGINE, 4TNV84T-DFM
NSN 2815-01-538-4237
VALVE LASH ADJUSTMENT**

INITIAL SETUP:**Tools and Special Tools**

Tool kit, general mechanic
(item 5, WP 0035 00)

Personnel Required

One

References

WP 0021 00

Equipment Condition

Valve cover assembly removed
(WP 0021 00)

WARNING

Metal jewelry will conduct electricity. All jewelry can become entangled in rotating components. Remove all jewelry when working on unit. Failure to comply may result in serious injury or death to personnel.

DO NOT wear loose clothing when performing checks, services, and maintenance. Failure to comply may result in serious injury or death to personnel.

High voltage is produced when unit is in operation. Make sure unit is completely shut down and free of any power source before attempting any repair or maintenance on unit. Failure to comply may result in serious injury or death to personnel.

High voltage is produced when unit is in operation. Never attempt to start or maintain unit unless it is properly grounded. Failure to comply may result in serious injury or death to personnel.

VALVE LASH ADJUSTMENT

1. Determine if cylinder no. 1 or cylinder no. 4 is in compression (Top Dead Center (TDC)) by rotating crankshaft pulley timing mark to align with arrow on engine block (figure 1). Check that both rocker arms for selected cylinder are loose which means that all valves for that cylinder are closed (compression cycle).
2. When cylinder no. 1 or cylinder no. 4 has been determined, cylinder no. 2 or cylinder no. 3 can be selected by rotating crankshaft pulley timing mark 180 degrees from engine block arrow.

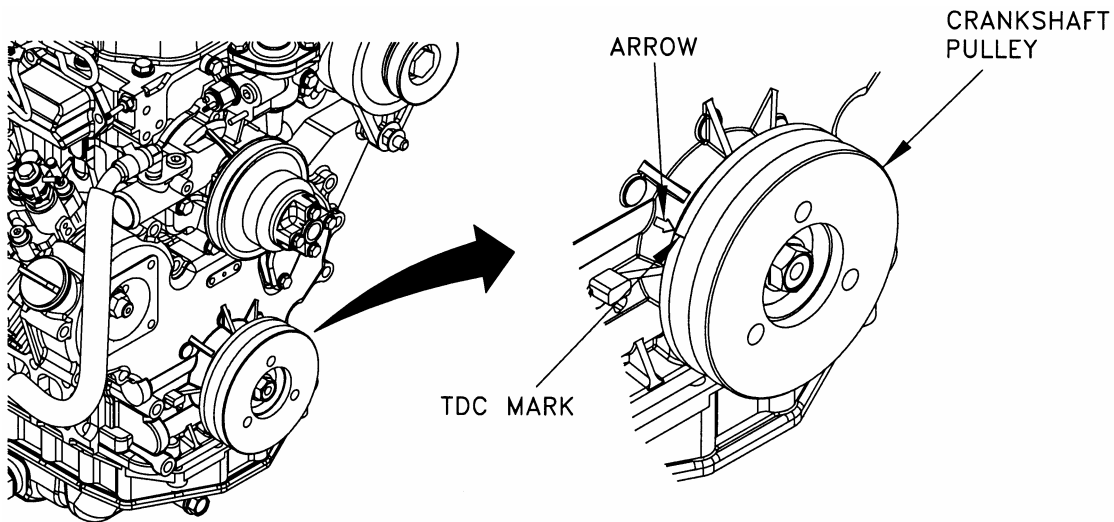

15KW-2815-24M-319A

Figure 1. No. 1 Cylinder at TDC.

3. Loosen lock nut (figure 2) and push down and hold selected rocker arm (figure 2) and adjust clearance to zero (figure 2). Tighten lock nut using adjustable wrench to hold valve bridge.

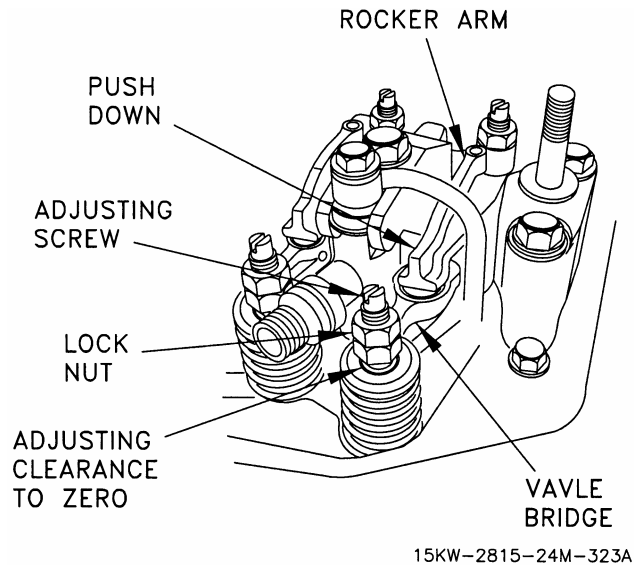

15KW-2815-24M-323A

Figure 2. Valve Bridge Clearance.

**FIELD LEVEL
DIESEL ENGINE, 4TNV84T-DFM
NSN 2815-01-538-4237
INTAKE MANIFOLD, AIR INLET HOSE, AND AIR HEATERS
REMOVAL, INSPECTION, TESTING, REPAIR, INSTALLATION**

INITIAL SETUP:**Tools and Special Tools**

Tool kit, general mechanic's
(item 5, WP 0035 00)

Personnel Required

One

Materials/Parts

Marker tags (item 7, WP 0064 00)

References

End item configuration manual

WARNING

Metal jewelry will conduct electricity. All jewelry can become entangled in rotating components. Remove all jewelry when working on unit. Failure to comply may result in serious injury or death to personnel.

DO NOT wear loose clothing when performing checks, services, and maintenance. Failure to comply may result in serious injury or death to personnel.

High voltage is produced when unit is in operation. Make sure unit is completely shut down and free of any power source before attempting any repair or maintenance on unit. Failure to comply may result in serious injury or death to personnel.

High voltage is produced when unit is in operation. Never attempt to start or maintain unit unless it is properly grounded. Failure to comply may result in serious injury or death to personnel.

REMOVAL

1. Loosen clamps (figure 1, items 1 and 2).
2. Slide clamps (figure 1, items 1 and 2) up onto air inlet hose (figure 1, item 3) and remove hose.
3. Tag and disconnect wires (figure 1, item 4) from air heaters (figure 1, item 5). See end item configuration manual for details.
4. Remove four bolts (figure 1, items 6 and 7), air intake bend (figure 1, item 8), two gaskets (figure 1, item 9), two air heaters (figure 1, item 5), and gasket (figure 1, item 10).
5. Remove bolt (figure 1, item 11), six bolts (figure 1, item 12) in staggered pattern, intake manifold (figure 1, item 13), and manifold gasket (figure 1, item 14) from cylinder head assembly (figure 1, item 15).

REMOVAL - Continued

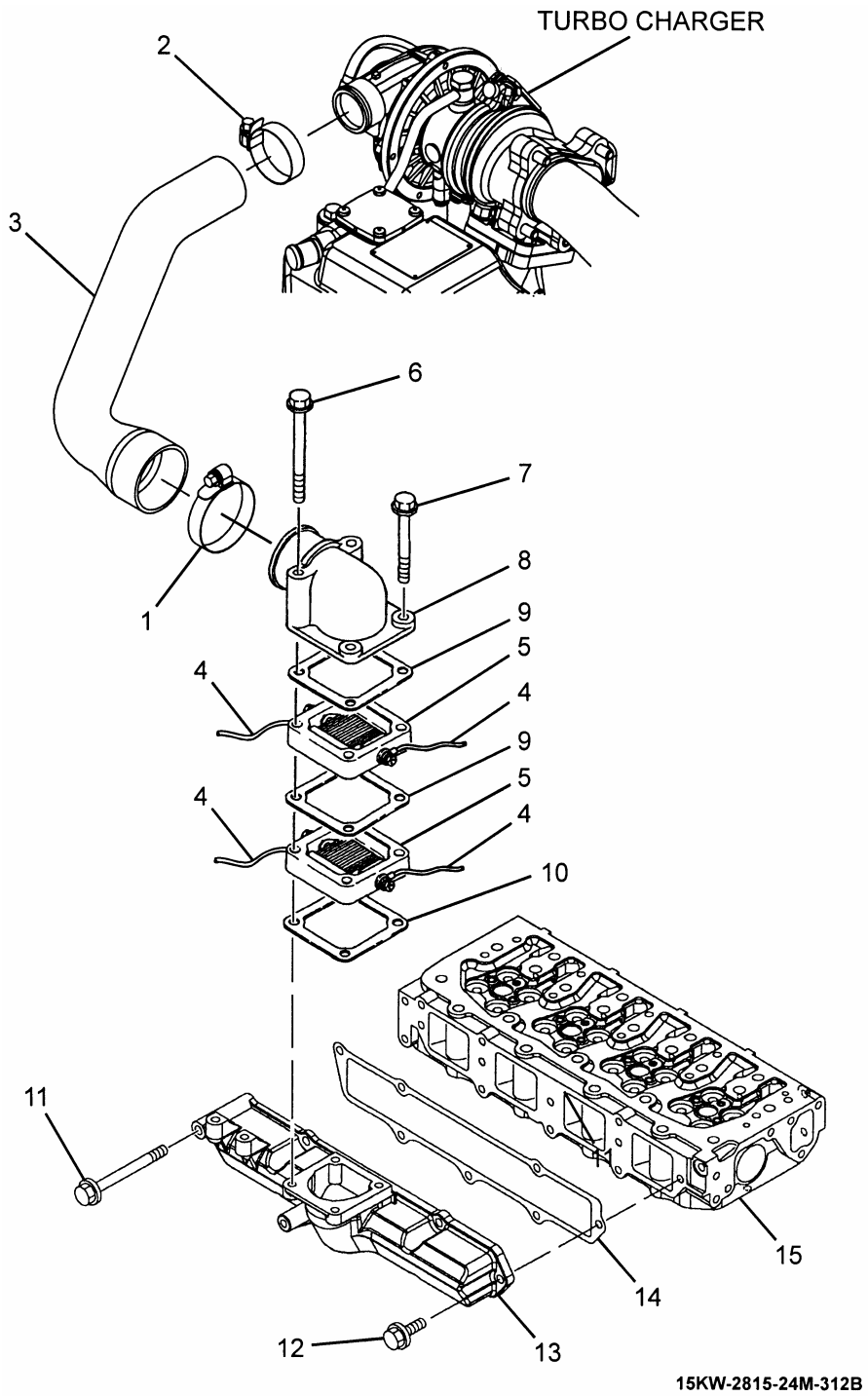

Figure 1. Intake Manifold, Air Inlet Hose, and Air Heaters.

INSPECTION

1. Inspect all parts for wear, cracks, and corrosion.
2. Inspect all hardware for stripped or damaged threads.
3. Inspect air heaters for signs of burning or damage.

REPAIR

Repair of this item is limited to removal and replacement.

TESTING**Air Heater**

Each air heater is rated 400 watts at 12 Vdc. The two air heaters are connected in series with each other. Most failures will open the heating element and show an open circuit to a standard multimeter (greater than 100,000 ohms). To test the air heaters, proceed as follows:

1. Tag and disconnect wire harness from each air heater.
2. Measure resistance between two terminals on each air heater.
3. If open, replace air heater.
4. Measure resistance between each terminals and metal frame of air heater.
5. If resistance is not greater than 1000,000 ohms, replace air heater.

INSTALLATION

1. Install manifold gasket (figure 1, item 14), manifold (figure 1, item 13), six bolts (figure 1, item 12) in staggered pattern, and bolt (figure 1, item 11) onto cylinder head assembly (figure 1, item 15). Torque bolts to 16.7 to 21.0 lb-ft (22.6 to 28.4 Nm) in same staggered pattern.
2. Install gasket (figure 1, item 10), two air heaters (figure 1, item 5), two gaskets (figure 1, item 9), air intake bend (figure 1, item 8), and four bolts (figure 1, items 7 and 6). Torque bolts to 16.7 to 21.0 lb-ft (22.6 to 28.4 Nm).
3. Connect wires (figure 1, item 4) to two air heaters (figure 1, item 5). Remove tags. See end item configuration manual for details.
4. Install air inlet hose (figure 1, item 3) and position and tighten clamps (figure 1, items 2 and 1).

END OF WORK PACKAGE

**FIELD LEVEL
DIESEL ENGINE, 4TNV84T-DFM
NSN 2815-01-538-4237
TURBOCHARGER OIL LINES
REMOVAL, INSPECTION, REPAIR, INSTALLATION**

INITIAL SETUP:**Tools and Special Tools**

Tool kit, general mechanic's
(item 5, WP 0035 00)

Personnel Required

One

WARNING

Metal jewelry will conduct electricity. All jewelry can become entangled in rotating components. Remove all jewelry when working on unit. Failure to comply may result in serious injury or death to personnel.

DO NOT wear loose clothing when performing checks, services, and maintenance. Failure to comply may result in serious injury or death to personnel.

High voltage is produced when unit is in operation. Make sure unit is completely shut down and free of any power source before attempting any repair or maintenance on unit. Failure to comply may result in serious injury or death to personnel.

High voltage is produced when unit is in operation. Never attempt to start or maintain unit unless it is properly grounded. Failure to comply may result in serious injury or death to personnel.

REMOVAL

1. Remove two bolts (figure 1, item 1), oil return line (figure 1, item 2), and O-ring (figure 1, item 3) from turbocharger (figure 1, item 4). Discard O-ring.
2. Remove bolt (figure 1, item 5) and retainer (figure 1, item 6) from cylinder head assembly (figure 1, item 7).
3. Remove nut (figure 1, item 8) from retainer (figure 1, item 9).
4. Remove banjo bolt (figure 1, item 10) and two seal washers (figure 1, items 11 and 12) from fuel injection pump assembly (figure 1, item 13). Discard seal washers.
5. Remove banjo bolt (figure 1, item 14) and two seal washers (figure 1, items 15) from cylinder block assembly (figure 1, item 16). Discard seal washers.
6. Remove banjo bolt (figure 1, item 17), two gaskets (figure 1, items 18), and oil line assembly (figure 1, item 19). Discard gaskets.

REMOVAL - Continued

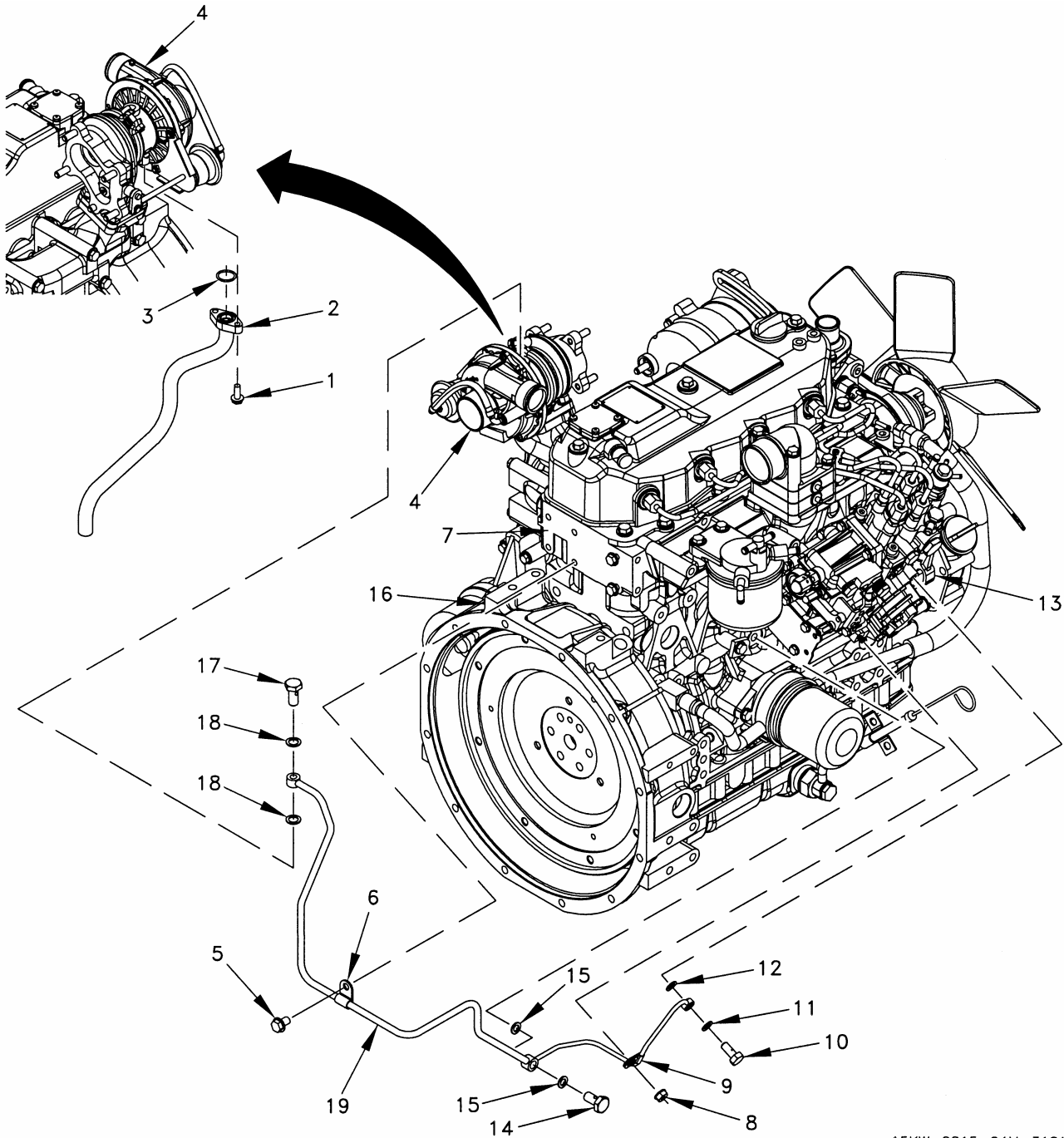

15KW-2815-24M-318A

Figure 1. Turbocharger Oil Lines.

INSPECTION

1. Inspect all parts for wear, cracks, and corrosion.
2. Inspect all hardware for stripped or damaged threads.
3. Inspect for signs of leakage.

REPAIR

Repair of this item is limited to removal and replacement.

INSTALLATION

1. Place oil line assembly (figure 1, item 19) into position on turbocharger (figure 1, item 4) and install two gaskets (figure 1, item 18) and banjo bolt (figure 1, item 17).
2. Install two seal washers (figure 1, item 15) and banjo bolt (figure 1, item 14) to connect oil line assembly (figure 1, item 19) to cylinder block assembly (figure 1, item 16).
3. Install two seal washers (figure 1, items 11 and 12) to connect oil line assembly (figure 1, item 19) to fuel injection pump assembly (figure 1, item 13).
4. Secure retainer (figure 1, item 9) to fuel injection pump assembly (figure 1, item 13) with nut (figure 1, item 8). Torque nut to 7.2-8.7 lb-ft (9.8-11.8 Nm).
5. Secure retainer (figure 1, item 6) to cylinder head assembly (figure 1, item 7) with bolt (figure 1, item 5). Torque bolt to 16.7-21.0 lb-ft (22.6-28.4 Nm).
6. Install O-ring (figure 1, item 3) onto oil return line (figure 1, item 2).
7. Install oil return line (figure 1, item 2) onto turbocharger (figure 1, item 4) with two bolts (figure 1, item 1). Torque bolt to 7.2-8.7 lb-ft (9.8-11.8 Nm).

END OF WORK PACKAGE

**FIELD LEVEL
DIESEL ENGINE, 4TNV84T-DFM
NSN 2815-01-538-4237
TURBOCHARGER ASSEMBLY AND EXHAUST MANIFOLD
REMOVAL, INSPECTION, REPAIR, INSTALLATION**

INITIAL SETUP:**Tools and Special Tools**

Tool kit, general mechanic's
(item 5, WP 00354 00)

References

WP 0027 00
End item configuration manual

Materials/Parts

Pressure sensitive tape (item 8, WP 0064 00)

Equipment Condition

Turbocharger oil lines removed
(WP 0027 00)
Exhaust and air inlet hoses removed
(end item configuration manual)

Personnel Required

One

WARNING

Metal jewelry will conduct electricity. All jewelry can become entangled in rotating components. Remove all jewelry when working on unit. Failure to comply may result in serious injury or death to personnel.

DO NOT wear loose clothing when performing checks, services, and maintenance. Failure to comply may result in serious injury or death to personnel.

High voltage is produced when unit is in operation. Make sure unit is completely shut down and free of any power source before attempting any repair or maintenance on unit. Failure to comply may result in serious injury or death to personnel.

High voltage is produced when unit is in operation. Never attempt to start or maintain unit unless it is properly grounded. Failure to comply may result in serious injury or death to personnel.

REMOVAL

1. Remove four bolts (figure 1, item 1), turbocharger assembly (figure 1, item 2), and gasket (figure 1, item 3) from exhaust manifold (figure 1, item 4).
2. Remove turbocharger assembly gasket (figure 1, item 5) and stud bolt (figure 1, item 6) if required.
3. Remove bolt (figure 1, item 7) from exhaust manifold (figure 1, item 4).
4. Remove three bolts (figure 1, item 8) from exhaust manifold (figure 1, item 4).
5. Remove four bolts (figure 1, item 9), exhaust manifold (figure 1, item 4), and exhaust manifold gasket (figure 1, item 10) from cylinder head assembly (figure 1, item 11).
6. Cover oil ports with pressure sensitive tape to prevent contamination or debris from entering turbocharger assembly (figure 1, item 2).

REMOVAL - Continued

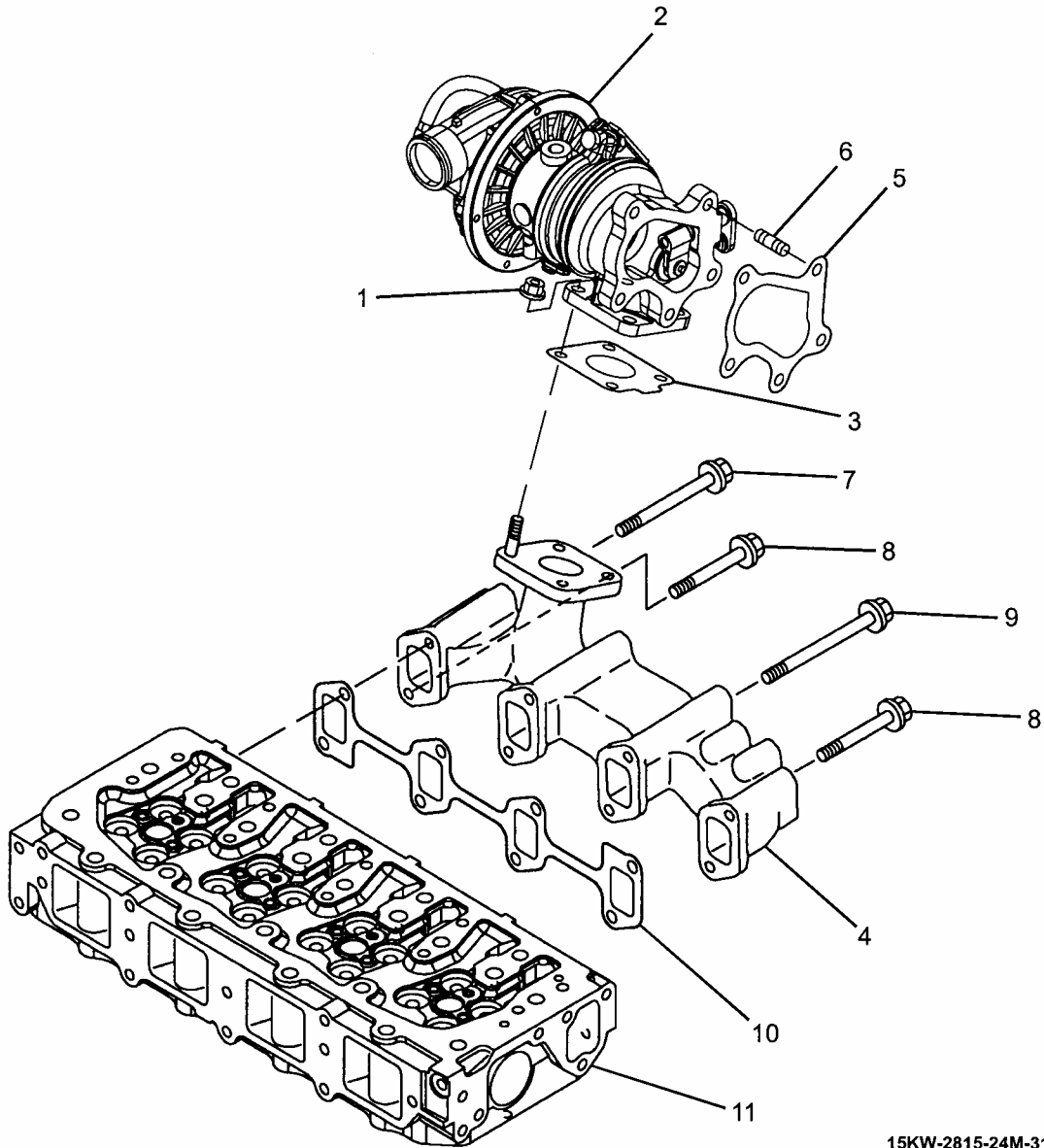

15KW-2815-24M-313

Figure 1. Turbocharger Assembly and Exhaust Manifold.

INSPECTION**Rotor Play**

1. Inspect all parts for wear, cracks, and corrosion.
2. Inspect all hardware for stripped or damaged threads.
3. Inspect air heaters for signs of burning or damage.
4. Listen for any abnormal sounds generated during turbocharger assembly (figure 1, item 2) operation. Abnormal sounds could mean damaged or worn bearings.
5. Measure axial play of turbine shaft (figure 2). Move turbine shaft in axial direction. Axial play must be within 0.001 to 0.002 inches (0.03 to 0.06 mm) with maximum limit of 0.003 inches (0.09 mm).

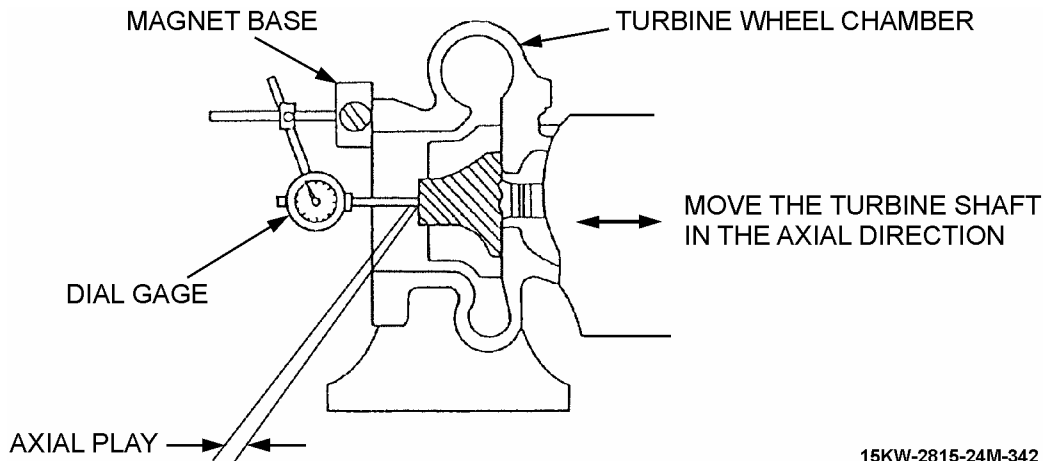

Figure 2. Axial Play Measurement.

6. If axial play exceeds limit, replace turbocharger assembly (figure 1, item 2).

INSPECTION - Continued

7. Measure radial play of turbine shaft (figure 3). Move turbine shaft in radial direction. Radial play must be within 0.003 to 0.005 inches (0.08 to 0.13 mm) with maximum limit of 0.006 inches (0.17 mm).

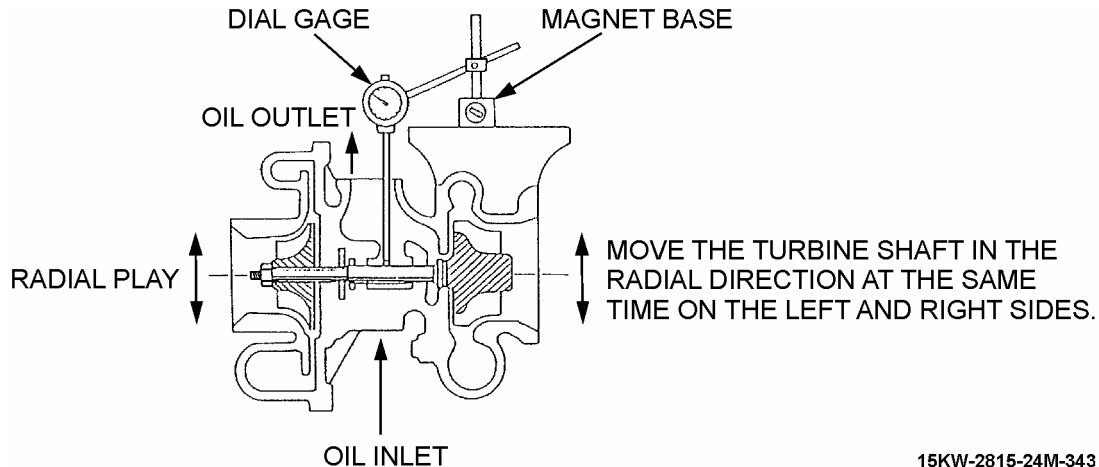

Figure 3. Radial Play Measurement.

8. If radial play exceeds limit, replace turbocharger assembly (figure 1, item 2).

Waste Gate Actuator Opening Pressure and Lift Test**NOTE**

Set dial gage on extension line of actuator rod. Piping and joints must be completely free from leakage. Secure turbocharger and dial gage tightly.

If an electric manometer is used, it shall have sufficient precision. Use of a mercury-column-type manometer in combination is recommended for calibration and daily check.

Speed for increasing/decreasing Control Pressure (Pc) shall be very slow near measuring point. If mm position is exceeded, restart from the beginning.

1. Set manometer Pc applied to waste gate actuator to zero and set dial gage to zero.
2. Gradually open pressure regulating valve and measure Pc value when actuator rod has traveled 2 mm. Do not apply over 71.0 psi (0.49 MPa) to actuator.
3. For hysteresis, let rod move to 3 mm first. Then, gradually close pressure regulating valve, measure pressure when rod has moved 2 mm, and obtain difference from pressure measured in step 2 above.

INSPECTION - Continued

Waste Gate Actuator Leak Test

1. Prepare waste gate actuator for testing (table 1 and figure 4).

Table 1. Required Test Equipment.

EQUIPMENT	REQUIREMENTS
Dial gage	Capable of measuring 0 to 0.39 inches (0 to 10 mm). (Flat head type recommended.)
Manometer	Mercury column or electrical type capable of measuring 0.0 to 29.0 psi (0.0 to 1,500 mmHg).
Pressure regulating valve	Fine adjustment capability in range of 0.0 to 28.4 psi (0.0 to 0.196 MPa).
Pressure reducing valve	Capable of reducing air supply pressure to 71.0 psi (0.49 MPa) or less.
Pressure gage	Bourdon tube pressure gage capable of measuring 0.0 to 142.0 (0.0 to 0.98 MPa).

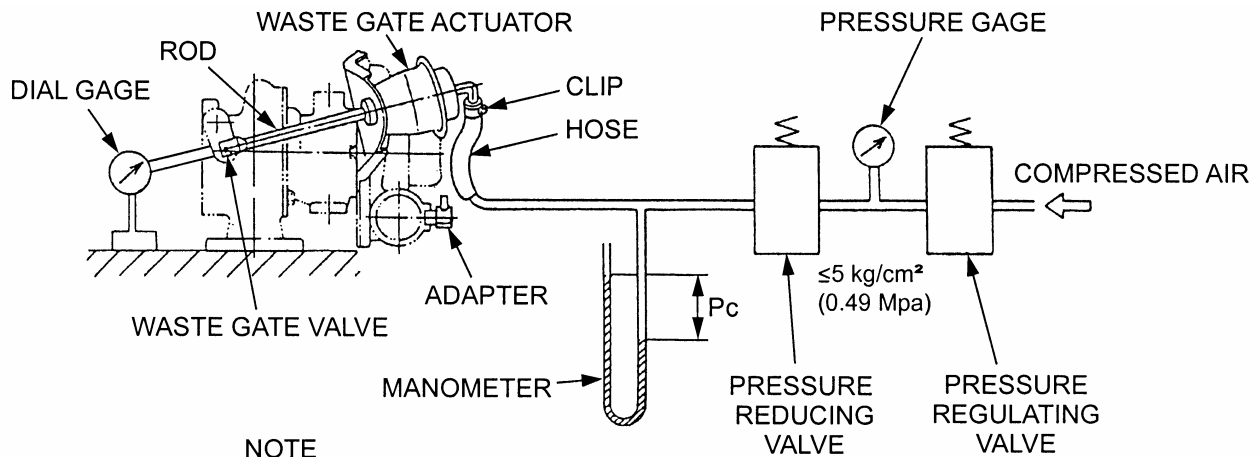

NOTE

P_c (CONTROL PRESSURE) VARIES WITH SET OUTPUT IN RANGE BETWEEN 600 AND 750 mmHg.

15KW-2815-24M-344A

Figure 4. Waste Gate Actuator Leak Test Setup.

2. Apply 17 psi (0.12 MPa) to actuator and hold for 1 minute. If pressure drop after 1 minute is less than 15.9 psi (0.11 MPa), replace turbocharger assembly (figure 1, item 2).

REPAIR

Repair of this item is limited to removal and replacement.

INSTALLATION

1. Ensure exhaust manifold (figure 1, item 4) and cylinder head assembly (figure 1, item 11) mating surfaces are clean and smooth.
2. Install exhaust manifold gasket (figure 1, item 10), exhaust manifold (figure 1, item 4), four bolts (figure 1, item 9), three bolts (figure 1, item 8), and bolt (figure 1, item 7). Torque bolts to 16.7 to 21.0 lb-ft (22.6 to 28.4 Nm).
3. Install stud bolt (figure 1, item 6) and turbocharger gasket (figure 1, item 5) onto turbocharger assembly (figure 1, item 2).
4. Ensure exhaust manifold (figure 1, item 4) and turbocharger assembly (figure 1, item 2) mating surfaces are clean and smooth.
5. Install gasket (figure 1, item 3), turbocharger assembly (figure 1, item 2), and four nuts (figure 1, item 1).
6. Install exhaust and air inlet hoses (end item configuration manual).
7. Install turbocharger oil lines (WP 0027 00).

END OF WORK PACKAGE

**FIELD LEVEL
DIESEL ENGINE, 4TNV84T-DFM
NSN 2815-01-538-4237
CRANKCASE ASSEMBLY AND DIPSTICK
REMOVAL, INSPECTION, REPAIR, INSTALLATION**

INITIAL SETUP:**Tools and Special Tools**

Tool kit, general mechanic's
(item 5, WP 0035 00)

Materials/Parts

Breakthrough cleaning solvent
(item 6, WP 0064 00)

Materials/Parts - Continued

Gasket forming compound
(item 2, WP 0064 00)
Wiping rag (item 5, WP 0064 00)

Personnel Required

One

WARNING

Metal jewelry will conduct electricity. All jewelry can become entangled in rotating components. Remove all jewelry when working on unit. Failure to comply may result in serious injury or death to personnel.

DO NOT wear loose clothing when performing checks, services, and maintenance. Failure to comply may result in serious injury or death to personnel.

High voltage is produced when unit is in operation. Make sure unit is completely shut down and free of any power source before attempting any repair or maintenance on unit. Failure to comply may result in serious injury or death to personnel.

High voltage is produced when unit is in operation. Never attempt to start or maintain unit unless it is properly grounded. Failure to comply may result in serious injury or death to personnel.

REMOVAL

1. Remove screw (figure 1, item 1), seal (figure 1, item 2), and dipstick (figure 1, item 3) from crankcase (figure 1, item 4).
2. Remove four bolts (figure 1, item 6), 22 bolts (figure 1, item 5), and crankcase (figure 1, item 4).
3. Remove two bolts (figure 1, item 7), two bolts (figure 1, item 8), and spacer (figure 1, item 9).
4. Remove plug (figure 1, item 10) and seal (figure 1, item 11).

REMOVAL - Continued

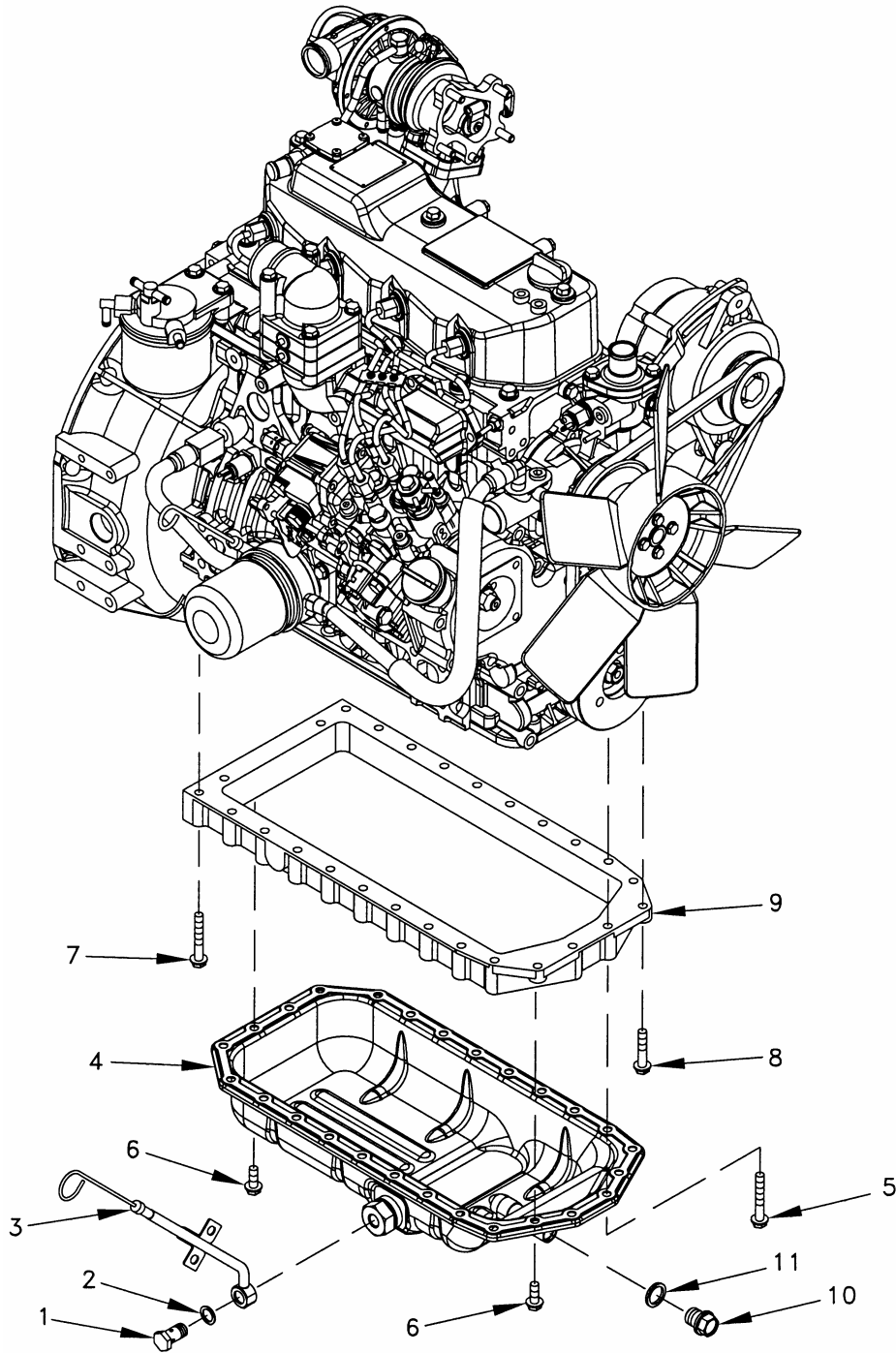

15KW-2815-24M-331A

Figure 1. Crankcase Assembly and Dipstick.

INSPECTION

1. Inspect all parts for damage, wear, cracks, and corrosion.
2. Inspect all hardware for stripped or damaged threads.
3. Check oil drain holes for obstructions.

WARNING

Cleaning solvent is flammable and toxic to eyes, skin and respiratory tract. Skin and eye protection are required when working in contact with cleaning solvent. Avoid repeated or prolonged contact. Work in ventilated area only. Failure to comply may result in serious injury or death to personnel.

4. Thoroughly clean crankcase (figure 1, item 4) with breakthrough cleaning solvent, brush, and a wiping rag.

REPAIR

Repair of this item is limited to removal and replacement.

INSTALLATION

1. Install seal (figure 1, item 11) and plug (figure 1, item 10).

WARNING

Cleaning solvent is flammable and toxic to eyes, skin and respiratory tract. Skin and eye protection are required when working in contact with cleaning solvent. Avoid repeated or prolonged contact. Work in ventilated area only. Failure to comply may result in serious injury or death to personnel.

2. Clean top and bottom mating surfaces of spacer (figure 1, item 9) with breakthrough cleaning solvent and a wiping rag.
3. Clean mating surface of engine (figure 1, item 4) with breakthrough cleaning solvent and a wiping rag.
4. Apply gasket forming compound to top mating surface of spacer (figure 1, item 9).
5. Install spacer (figure 1, item 9) and secure with two bolts (figure 1, item 8) and two bolts (figure 1, item 7).
6. Apply gasket forming compound to mating surface of crankcase (figure 1, item 4).
7. Install crankcase (figure 1, item 4) with four bolts (figure 1, item 6), and 22 bolts (figure 1, item 5).
8. Install dipstick (figure 1, item 3), seal (figure 1, item 2), and screw (figure 1, item 1).

END OF WORK PACKAGE

**FIELD LEVEL
DIESEL ENGINE, 4TNV84T-DFM
NSN 2815-01-538-4237
FLYWHEEL ASSEMBLY AND FLYWHEEL HOUSING
REMOVAL, INSPECTION, REPAIR, INSTALLATION**

INITIAL SETUP:**Tools and Special Tools**

Tool kit, general mechanic's
(item 5, WP 0035 00)

Materials/Parts

Breakthrough cleaning solvent
(item 6, WP 0064 00)
Engine lubricating oil
(item 4, WP 0064 00)

Materials/Parts - Continued

Gasket forming compound
(item 2, WP 0064 00)
Wiping rag (item 5, WP 0064 00)

Personnel

One

WARNING

Metal jewelry will conduct electricity. All jewelry can become entangled in rotating components. Remove all jewelry when working on unit. Failure to comply may result in serious injury or death to personnel.

DO NOT wear loose clothing when performing checks, services, and maintenance. Failure to comply may result in serious injury or death to personnel.

High voltage is produced when unit is in operation. Make sure unit is completely shut down and free of any power source before attempting any repair or maintenance on unit. Failure to comply may result in serious injury or death to personnel.

High voltage is produced when unit is in operation. Never attempt to start or maintain unit unless it is properly grounded. Failure to comply may result in serious injury or death to personnel.

REMOVAL**WARNING**

Flywheel assembly is heavy and if dropped or mishandled may result in damage to equipment and injury to personnel.

1. Remove six bolts (figure 1, item 1), and flywheel assembly (figure 1, item 2).
2. Remove six bolts (figure 1, item 3), four bolts (figure 1, item 4), and flywheel housing (figure 1, item 5).
3. Remove flywheel cover cap (figure 1, item 6).
4. Remove alignment pin (figure 1, item 7) only if damaged.

NOTE

An alternate procedure to remove oil seal is to wrap crankshaft end with masking tape to protect surface and gently pry out seal with a small screwdriver.

5. Remove six bolts (figure 1, item 8), three bolts (figure 1, item 9), and oil seal case assembly (figure 1, item 10).
6. Remove and discard oil seal (figure 1, item 11).
7. Remove alignment pin (figure 1, item 12) only if damaged.

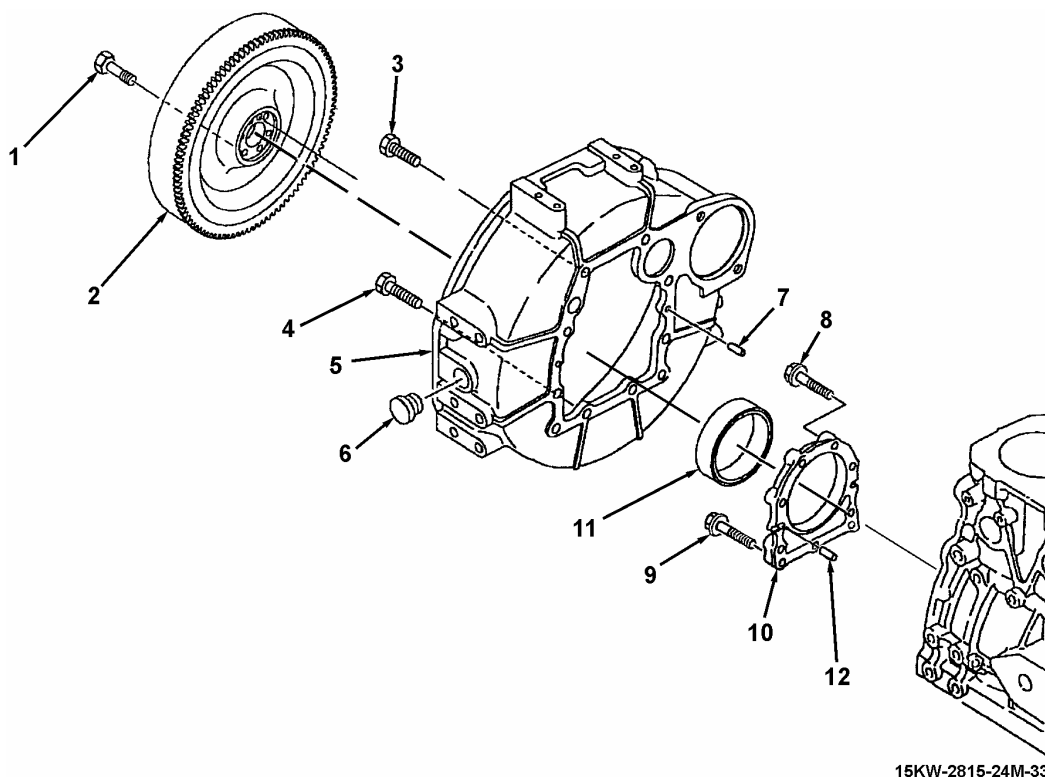

Figure 1. Flywheel Assembly and Flywheel Housing.

INSPECTION

1. Inspect all parts for damage, wear, cracks, and corrosion.
2. Inspect all hardware for stripped or damaged threads.
3. Inspect ring gear on flywheel assembly (figure 1, item 2) for damaged or missing teeth.
4. Inspect mating surfaces for damage.

REPAIR

Repair of this item is limited to removal and replacement.

INSTALLATION

1. Install alignment pin (figure 1, item 12) into oil seal case assembly (figure 1, item 10).
2. Install new oil seal (figure 1, item 11) into oil seal case assembly (figure 1, item 10).

WARNING

Cleaning solvent is flammable and toxic to eyes, skin, and respiratory tract. Skin and eye protection are required when working in contact with cleaning solvent. Avoid repeated or prolonged contact. Work in ventilated area only. Failure to comply may result in serious injury to personnel.

3. Clean mating surface of oil seal case assembly (figure 1, item 10) with breakthrough cleaning solvent and a wiping rag.

CAUTION

Ensure gasket forming compound is not applied to oil seal or damage to oil seal will result.

4. Apply gasket forming compound to mating surface of oil seal case assembly (figure 1, item 10) and install oil seal case assembly with three bolts (figure 1, item 9).
5. Install six bolts (figure 1, item 8).
6. Install alignment pin (figure 1, item 7) into flywheel housing (figure 1, item 5).
7. Install flywheel cover cap (figure 1, item 6) into flywheel housing (figure 1, item 5).
8. Install flywheel housing (figure 1, item 5) with four bolts (figure 1, item 4).
9. Install six bolts (figure 1, item 3).

WARNING

Flywheel assembly is heavy and if dropped or mishandled may result in damage to equipment and injury to personnel.

10. Install flywheel assembly (figure 1, item 2) with six bolts (figure 1, item 1).

END OF WORK PACKAGE

**SUSTAINMENT LEVEL
DIESEL ENGINE, 4TNV84T-DFM
NSN 2815-01-538-4237
PREPARATION FOR STORAGE OR SHIPMENT**

PRESERVATION

There are no special preservation requirements. The engine should be started and run until operating temperature is reached a minimum of every 60 days and ideally every 30 days. If the engine is not going to be started for over 60 days, recommend you contact the Army Material Command Major Subordinate Command responsible for engines to obtain special maintenance, storage and preservation requirements and procedures.

PACKING

Package per MIL-STD-2073-1D, as required.

MARKING

Mark for shipment or storage per MIL-STD-129.

USE OF CORROSION PREVENTIVE COMPOUNDS, MOISTURE BARRIERS, AND DESICCANT MATERIALS

Refer to Corrosion Prevention and Control, TB 43-0213.

SPECIAL INSTRUCTIONS FOR ADMINISTRATIVE STORAGE

Placement of equipment in administrative storage should be for short periods of time when a shortage of maintenance effort exists. Items should be in mission readiness within 24 hours or within the time factors as determined by the directing authority.

Before placing the equipment in administrative storage, current preventive maintenance checks and services should be completed, shortcomings and deficiencies should be corrected, and all Modification Work Orders (MWOs) and Modification Instructions (MI) should be applied.

Inside storage is preferred for items selected for administrative storage. If inside storage is not available, trucks, vans, CONEX containers, and other containers may be used.

For storage information, refer to TM 740-90-1.

**FIELD LEVEL
DIESEL ENGINE, 4TNV84T-DFM
NSN 2815-01-538-4237
TORQUE LIMITS**

INTRODUCTION

This work package contains the torque standards for specific types and sizes of hardware. It defines the different types of bolts by grade. Special torque values and sequences are listed in the specific maintenance procedure.

TORQUE TABLES

How To Use Torque Tables

1. Measure diameter of screw being installed (figure 1).
2. Count number of threads per inch or use a pitch grade.

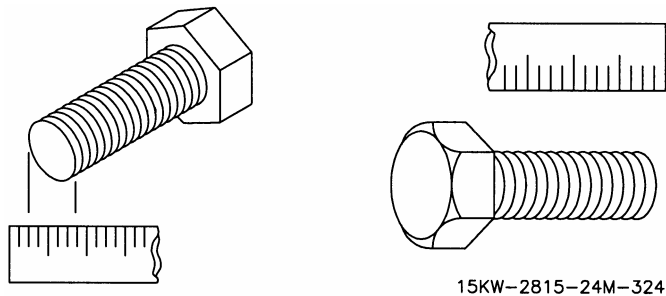

Figure 1. Measuring Screw.

TORQUE TABLES - Continued

3. Under heading SIZE, look down DIA IN. column until you find diameter of screw being installed (table 1 or table 2). (There will usually be two lines beginning with same size.)
4. Under heading SIZE, look down THREADS PER IN. column to find numbers of threads per inch that match number of threads counted in step 2. (Not required for metric screws.)

NOTE

Manufacturer's marks may vary. Standard is all SAE Grade 5 (3-line). Metric screws are of three grades: 8.8, 10.9, and 12.9. Grades and manufacturer's marks appear on the screw head.

5. To find the grade screw being installed, match markings on screw head to correct picture of CAPSCREW HEAD MARKINGS (figure 2 or figure 3).

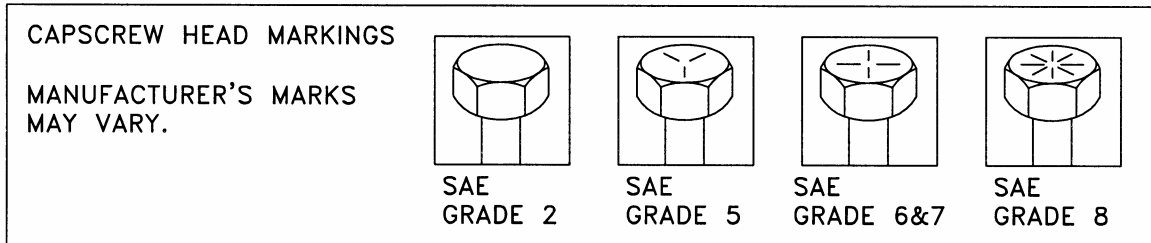

15KW-2815-24M-325

Figure 2. Capscrew Head Markings (Standard).

TORQUE TABLES - Continued

Table 1. Standard Dry Torque Limits.

SIZE			SAE GRADE NO. 2		SAE GRADE NO. 5		SAE GRADE NO. 6 OR 7		SAE GRADE NO. 8	
DIA IN.	THREADS PER IN.	DIA MM	LB-FT	NM	LB-FT	NM	LB-FT	NM	LB-FT	NM
1/4	20	6.35	5	7	8	11	10	14	12	16
1/4	28	6.35	6	9	10	14	12	16	14	19
5/16	18	7.94	11	15	17	23	21	28	25	34
5/16	24	7.94	12	16	19	26	24	33	25	34
3/8	16	9.53	20	27	30	41	40	54	45	61
3/8	24	9.53	23	31	35	47	45	61	50	68
7/16	14	11.11	30	41	50	68	60	81	70	95
7/16	20		35	47	55	75	70	95	90	108
1/2	13	12.70	50	68	75	102	95	129	110	149
1/2	20		55	75	90	122	100	135	120	163
9/16	12	14.29	65	85	110	149	135	183	150	203
9/16	18		75	102	120	163	150	203	170	231
5/8	11	15.88	90	122	150	203	190	258	220	298
5/8	18		100	136	180	244	210	285	240	325
3/4	10	19.05	160	217	260	353	240	434	380	515
3/4	16		180	244	300	407	360	488	420	597
7/8	9	22.23	140	190	400	542	520	705	600	814
7/8	14		155	210	440	597	580	786	660	895
1	8	25.40	220	298	580	786	800	1085	900	1220
1	12		240	325	640	868	860	1166	1000	1350
1-1/8	7	25.58	300	407	800	1085	1120	1519	1280	1736
1-1/8	12		340	461	880	1193	1260	1709	1440	1953
1-1/4	7	31.75	420	570	1120	1519	1580	2142	1820	2468
1-1/4	12		460	624	1240	1681	1760	2387	2000	2712
1-3/8	6	34.93	560	759	1460	1980	2080	2820	2380	3227
1-3/8	12		640	868	1680	2278	2360	3227	2720	3688
1-1/2	6	38.10	740	1003	1940	2631	2780	3770	3160	4285
1-1/2	12		840	1139	2200	2983	3100	4204	3560	4827

TORQUE TABLES - Continued

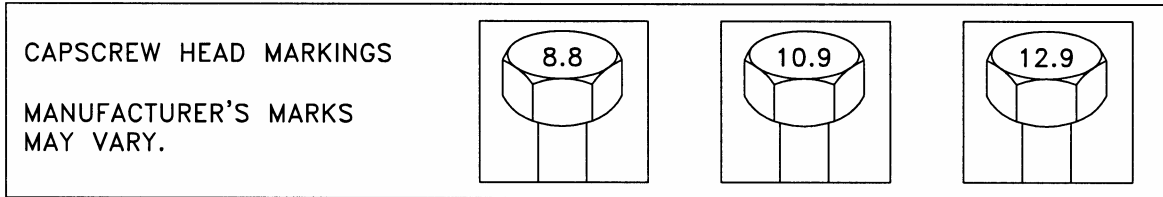

15KW-2815-24M-326

Figure 3. Capscrew Head Markings (Metric).

Table 2. Metric Dry Torque Limits.

SIZE		METRIC GRADE 8.8		METRIC GRADE 10.9		METRIC GRADE 12.9	
DIA IN.	DIA MM	LB-FT	NM	LB-FT	NM	LB-FT	NM
0.157	4	2	3	3	4	4	5
0.197	5	4	5	6	8	7	9
0.237	6	7	9	10	14	11	15
0.276	7	11	15	16	32	20	27
0.315	8	18	24	25	34	29	39
0.394	10	32	43	47	64	58	79
0.473	12	58	79	83	113	100	136
0.630	16	144	195	196	266	235	319
0.709	18	190	258	269	365	323	438
0.788	20	260	353	366	496	440	597
0.867	22	368	499	520	705	678	919
0.946	24	470	637	664	900	794	1077
1.064	27	707	959	996	1351	1235	1675
1.182	30	967	1311	1357	1840	1630	2210

CHAPTER 4
SUPPORTING INFORMATION
FOR
DIESEL ENGINE

CHAPTER 4**SUPPORTING INFORMATION
FOR
DIESEL ENGINE**

WORK PACKAGE INDEX

<u>Title</u>	<u>WP Sequence No.</u>
REFERENCES.....	0033 00
MAINTENANCE ALLOCATION CHART (MAC) INTRODUCTION	0034 00
MAINTENANCE ALLOCATION CHART (MAC)	0035 00
REPAIR PARTS AND SPECIAL TOOLS LIST INTRODUCTION	0036 00
TURBOCHARGED DIESEL ENGINE REPAIR PARTS LIST	0037 00
CYLINDER BLOCK ASSEMBLY REPAIR PARTS LIST	0038 00
ROCKER ARM SHAFT ASSEMBLY REPAIR PARTS LIST	0039 00
CYLINDER HEAD ASSEMBLY REPAIR PARTS LIST	0040 00
VALVE COVER ASSEMBLY REPAIR PARTS LIST	0041 00
CONNECTING ROD AND PISTON ASSEMBLY REPAIR PARTS LIST	0042 00
CAMSHAFT, DRIVING GEAR, AND IDLE GEAR ASSEMBLIES REPAIR PARTS LIST	0043 00
FLYWHEEL ASSEMBLY REPAIR PARTS LIST	0044 00
CRANKSHAFT ASSEMBLY REPAIR PARTS LIST	0045 00
GEAR CASE ASSEMBLY REPAIR PARTS LIST	0046 00
COOLING SYSTEM REPAIR PARTS LIST	0047 00
FAN ASSEMBLY REPAIR PARTS LIST	0048 00
FUEL SYSTEM REPAIR PARTS LIST	0049 00
FUEL INJECTION VALVE SYSTEM REPAIR PARTS LIST	0050 00
FUEL INJECTION ASSEMBLY REPAIR PARTS LIST	0051 00
OIL FILTER AND OIL COOLER REPAIR PARTS LIST	0052 00
OIL BYPASS VALVE REPAIR PARTS LIST	0053 00
OIL PUMP ASSEMBLY REPAIR PARTS LIST	0054 00
CRANKCASE ASSEMBLY REPAIR PARTS LIST	0055 00
INTAKE MANIFOLD REPAIR PARTS LIST	0056 00
TURBOCHARGER ASSEMBLY REPAIR PARTS LIST	0057 00
STARTER MOTOR ASSEMBLY REPAIR PARTS LIST	0058 00
GENERATOR REPAIR PARTS LIST	0059 00
SPECIAL TOOLS LIST	0060 00
BULK MATERIAL LIST	0061 00
NATIONAL STOCK NUMBER INDEX	0062 00
PART NUMBER INDEX.....	0063 00
EXPENDABLE AND DURABLE ITEMS LIST	0064 00

**FIELD LEVEL
DIESEL ENGINE, 4TNV84T-DFM
NSN 2815-01-538-4237
REFERENCES**

SCOPE

This work package lists all field manuals, forms, technical bulletins, technical manuals, miscellaneous publications, and military standards and specifications for use with the diesel engine.

FIELD MANUALS

FM 3-3.....	Chemical and Biological Contamination Avoidance
FM 3-3-1.....	Nuclear Contamination Avoidance
FM 3-4.....	NBC Protection
FM 3-5.....	NBC Decontamination
FM 4-25.11.....	First Aid
FM 9-207.....	Operation and Maintenance of Ordnance Materiel in Cold Weather (0° to -65°)
FM 10-67-1.....	Concepts and Equipment of Petroleum Operations
FM 21-30.....	Military Symbols

FORMS

DA Form 2028.....	Recommended Changes to Publications and Blank Forms
DA Form 2028-E.....	Recommended Changes to Publications and Blank Forms (EGA)
DA Form 2062.....	Hand Receipt
DA Form 2404.....	Equipment Inspection and Maintenance Worksheet
DA Form 2407.....	Maintenance Request
DA Form 2408.....	Equipment Log Assembly (Records)
DA Form 2408-9.....	Equipment Control Record
DA Form 2408-20.....	Oil Analysis Log
DA Form 5988-E.....	Equipment Inspection and Maintenance Worksheet
DD Form 314.....	Preventive Maintenance Schedule and Record
DD Form 518.....	Accident Identification Card
DD Form 1397.....	Processing and Deprocessing Record for Shipment, Storage, and Issue of Vehicles and Spare Engines
DD Form 2326.....	Preservation and Packing Data
Form 20.....	Occupational Safety and Health Act (OSHA) Material Safety Data Sheet
SF 361.....	Transportation Discrepancy Report
SF 364.....	Report of Discrepancy
SF 368.....	Product Quality Deficiency Report

TECHNICAL BULLETINS

TB 9-6116-643-24.....	Warranty Program for Generator Set, Tactical Quiet, 15 KW, 50/60 and 400 HZ, MEP-804A and MEP-814A
TB 43-0213.....	Corrosion Prevention and Control

TECHNICAL MANUALS

TM 55-1500-323-24 Installation Practices, Aircraft Electric and Electronic Wiring
TM 740-90-1 Administrative Storage of Equipment
TM 750-244-6 Procedures for Destruction of Tank-Automotive Materiel to Prevent Enemy
Use
TM 750-254 Cooling Systems: Tactical Vehicles

MISCELLANEOUS PUBLICATIONS

AR 385-11 Safety Ionizing Protection
AR 700-138 Army Logistics Readiness and Sustainability
AR 735-11-2 Reporting of Supply Discrepancies
AR 750-1 Army Materiel Maintenance Policy
CTA 8-100 Army Medical Department Expendable/Durable Items
CTA 50-970 Expendable/Durable Items (Except: Medical, Class V Repair Parts, and
Heraldic Items)
DA PAM 25-30 Consolidated Index of Army Publications and Blank Forms
DA PAM 738-750 Functional Users Manual for The Army Maintenance Management System
(TAMMS)
TC 38-3 Guide for Basic Military Preservation and Packing

MILITARY STANDARDS AND SPECIFICATIONS

A-A-62624 Antifreeze
MIL-DTL-83133 Turbine Fuels, Aviation, Grades JP-4, JP-5, and JP-5/JP-8 ST
MIL-L-46167 Lubricating Oil, Internal Combustion Engine, Arctic
MIL-PRF-2104 Lubricating Oil, Internal Combustion Engine, Combat/Tactical Service
MIL-STD-129 Markings for Shipment or Storage
MIL-STD-2073-1D Standard Practice for Military Packaging

**FIELD AND SUSTAINMENT LEVEL
DIESEL ENGINE, 4TNV84T-DFM
NSN 2815-01-538-4237
MAINTENANCE ALLOCATION CHART (MAC)**

INTRODUCTION

The Army Maintenance System Mac

This introduction provides a general explanation of all maintenance and repair functions authorized at the two maintenance levels under the Two-Level Maintenance System concept.

This MAC (immediately following the introduction) designates overall authority and responsibility for the performance of maintenance functions on the identified end item or component. The application of the maintenance functions to the end item or component shall be consistent with the capacities and capabilities of the designated maintenance levels, which are shown on the MAC in column (4) as:

Field - includes three subcolumns, Operator/Crew maintenance (C), Service Maintenance (O), and Field Maintenance (F)

Sustainment - includes two sub-columns, Below Depot (H) and Depot (D)

The tools and test equipment requirements (immediately following the MAC) list the tools and test equipment (both special tools and common tool sets) required for each maintenance function as referenced from the MAC.

The remarks (immediately following the tools and test equipment requirements) contain supplemental instructions and explanatory notes for a particular maintenance function.

Maintenance Functions, Section I.

Maintenance functions are to be limited to and defined as below:

1. Inspect. To determine the serviceability of an item by comparing its physical, mechanical, and/or electrical characteristics with established standards through examination (e.g., by sight, sound, or feel). This includes scheduled inspection and gaging and evaluation of cannon tubes.
2. Test. To verify serviceability by measuring the mechanical, pneumatic, hydraulic, or electrical characteristics of an item and comparing those characteristics with prescribed standards on a scheduled basis, i.e., load testing of lift devices and hydrostatic testing of pressure hoses.
3. Service. Operations required periodically keeping an item in proper operating condition: e.g., to clean (includes decontaminate, when required), to preserve, to drain, to paint, or to replenish fuel, lubricants, chemical fluids, or gases. This includes scheduled exercising and purging of recoil mechanisms. The following are examples of service functions:
 - a. Unpack. To remove from packing box for service or when required for the performance of maintenance operations.
 - b. Repack. To return item to packing box after service and other maintenance operations.
 - c. Clean. To rid the item of contamination.
 - d. Touch up. To spot paint scratched or blistered surfaces.
 - e. Mark. To restore obliterated identification.
4. Adjust. To maintain or regulate, within prescribed limits, by bringing into proper position, or by setting the operating characteristics to specified parameters.

5. **Align.** To adjust specified variable elements of an item to bring about optimum or desired performance.
6. **Calibrate.** To determine and cause corrections to be made or to be adjusted on instruments or test, measuring, and diagnostic equipment used in precision measurement. Consists of comparisons of two instruments, one of which is a certified standard of known accuracy, to detect and adjust any discrepancy in the accuracy of the instrument being compared.
7. **Remove/Install.** To remove and install the same item when required to perform service or other maintenance functions. Install may be the act of emplacing, seating, or fixing into position a spare, repair part, or module (component or assembly) in a manner to allow the proper functioning of an equipment or system.
8. **Paint.** To prepare and spray color coats of paint so that the ammunition can be identified and protected. The color indicating primary use is applied, preferably, to the entire exterior surface as the background color of the item. Other markings are to be repainted as original so as to retain proper ammunition identification.
9. **Replace.** To remove an unserviceable item and install a serviceable counterpart in its place. "Replace" is authorized by the MAC and assigned maintenance level is shown as the third position code of the Source, Maintenance and Recoverability (SMR) code.
10. **Repair.** The application of maintenance services including fault location/troubleshooting, removal/installation, disassembly/assembly procedures, and maintenance actions to identify troubles and restore serviceability to an item by correcting specific damage, fault, malfunction, or failure in a part, subassembly, module (component or assembly), end item, or system.

NOTE

The following definitions are applicable to the "repair" maintenance function:

Services. Inspect, test, service, adjust, align, calibrate, and/or replace.

Fault location/troubleshooting. The process of investigating and detecting the cause of equipment malfunctioning; the act of isolating a fault within a system or Unit Under Test (UUT).

Disassembly/ assembly. The step-by-step breakdown (taking apart) of a spare/functional group coded item to the level of its least component, that is assigned an SMR code for the level of maintenance under consideration (i.e., identified as maintenance significant).

Actions. Welding, grinding, riveting, straightening, facing, machining, and/or resurfacing.

11. **Overhaul.** That maintenance effort (service/action) prescribed to restore an item to a completely serviceable/ operational condition as required by maintenance standards in appropriate technical publications. Overhaul is normally the highest degree of maintenance performed by the Army. Overhaul does not normally return an item to like new condition.
12. **Rebuild.** Consists of those services/actions necessary for the restoration of unserviceable equipment to a like new condition in accordance with original manufacturing standards. Rebuild is the highest degree of material maintenance applied to Army equipment. The rebuild operation includes the act of returning to zero those age measurements (e.g., hours/ miles) considered in classifying Army equipment/ components.

Explanation of Columns in the MAC, Section II.

Column (1) Group Number. Column (1) lists Functional Group Code (FGC) numbers, the purpose of which is to identify maintenance significant components, assemblies, subassemblies, and modules with the Next Higher Assembly (NHA).

Column (2) Component/Assembly. Column (2) contains the item names of components, assemblies, subassemblies, and modules for which a maintenance function is authorized.

Column (3) Maintenance Function. Column (3) lists the functions to be performed on the item listed in column (2). (For detailed explanation of these functions refer to Maintenance Functions outlined above).

Column (4) Maintenance Category. Column (4) specifies each level of maintenance authorized to perform each function listed in column (3), by indicating work item required (expressed as man-hours in whole hours or decimals) in the appropriate sub-column. This work-time figure represents the active time required to perform that maintenance function at the indicated level of maintenance. If the number or complexity of tasks within the listed maintenance function varies at different maintenance levels, appropriate work-time figures are shown for each level. The work-time figure represents the average time required to restore an item (assembly, subassembly, component, module, end item, or system) to a serviceable condition under typical field operating conditions. This time includes preparation time (including any necessary disassembly/ assembly time), troubleshooting/fault location time, and quality assurance time in addition to the time required to perform the specific tasks identified for the maintenance functions authorized in the MAC. The symbol designations for the various maintenance levels under the Two-Level Maintenance concept are as follows:

Field:

C-Operator or Crew maintenance
O-Service maintenance
F-Field maintenance

Sustainment:

L-Specialized Repair Activity
H-Below depot maintenance
D-Depot maintenance

NOTE

The L maintenance level is not included in column (4) of the MAC. Functions to this level of maintenance are identified by work time figure in the H column of column (4), and an associated reference code is used in the REMARKS column (6). This code is keyed to the remarks and the SRA complete repair application is explained there.

Column (5) Tools and Test Equipment Reference Code. Column 5 specifies, by code, those common tools sets (not individual tools), Common Test, Measurement and Diagnostic Equipment (TMDE), and special tools, special TMDE and special support equipment required to perform the designated function. Codes are keyed to the entries in the tools and test equipment table.

Column (6) Remarks Code. When applicable, this column contains a letter code, in alphabetical order, which is keyed to the remarks table entries.

Explanation of Columns in the Tools and Test Equipment Requirements, Section III.

Column (1) Tool or Test Equipment Reference Code. The tool and test equipment reference code correlates with a code used in column 5, Section II of the MAC.

Column (2) Maintenance Level. The lowest level of maintenance authorized to use the tool or test equipment.

Column (3) Nomenclature. Name or identification of the tool or test equipment.

Column (4) National Stock Number (NSN). The NSN of the tool or test equipment.

Column (5) Tool Number. The manufacturer's part number, model number, or type number.

Explanation of Columns in the Remarks, Section IV.

Column (1) Remarks Code. The code recorded in column (6) of the MAC.

Column (2) Remarks. This column lists information pertinent to the maintenance function being performed as indicated in the MAC.

**FIELD AND SUSTAINMENT LEVEL
DIESEL ENGINE, 4TNV84T-DFM
NSN 2815-01-538-4237
MAINTENANCE ALLOCATION CHART (MAC)**

MAC*Table 1. Maintenance Allocation Chart.*

(1) GROUP NUMBER	(2) COMPONENT/ ASSEMBLY	(3) MAINTENANCE FUNCTION	(4) MAINTENANCE LEVEL					(5) TOOLS AND EQUIPMENT REF CODE	(6) REMARKS CODE
			FIELD			SUSTAINMENT			
			CREW	SERVICE	FIELD	BELOW DEPOT	DEPOT		
			C	O	F	H	D		
00	ENGINE ASSEMBLY	Inspect		0.2	0.5	0.5			
		Test			0.5	0.5		3,4,5	
		Service		0.3	0.5			1,5	
		Adjust			1.0			1,5	
		Replace			5.0			1,5	
		Repair			1.0	2.0		3,4,5	
		Overhaul				12.0		1,4,5	
01	ENGINE BLOCK ASSEMBLY	Inspect			0.5	0.5			
		Remove/Install				2.0		1,5	
		Repair				3.0		1,4,5	
0101	ROCKER ARM ASSEMBLY	Inspect			0.5				
		Adjust			1.0			5	
		Remove/Install				1.0		4,5	
		Replace				1.0		4,5	
		Repair				1.5		4,5	
0102	CYLINDER HEAD ASSEMBLY	Inspect			0.2	0.4			
		Test				0.3		3,4,5	
		Remove/Install			2.0			1,5	
		Replace			2.0			1,5	
		Repair				3.0		3,4,5	
0103	VALVE COVER ASSEMBLY	Inspect			0.2				
		Remove/Insta			0.5			5	
		Replace			0.5			5	
0104	CONNECTING ROD AND PISTON ASSEMBLY	Inspect				0.5			
		Test				0.3		3,4,5	
		Remove/Install				4.0		1,3,5	
		Replace				4.0		1,3,5	
		Repair				4.0		1,4,5	
0105	IDLE GEAR ASSEMBLY	Inspect			0.2				
		Remove/Install			2.0			3,5	
		Replace			2.0			1,5	
0106	CAMSHAFT ASSEMBLY	Inspect				0.5			
		Test				0.5		3,5	
		Remove/Install				4.0		5	
		Replace				4.0		5	
		Repair				4.0		1,4,5	
0107	FLYWHEEL HOUSING ASSEMBLY	Inspect			0.2				
		Remove/Install			1.0			1,5	
		Replace			1.0			1,5	
		Repair			0.1			1,3,5	

MAC - Continued

Table 1. Maintenance Allocation Chart - Continued.

(1) GROUP NUMBER	(2) COMPONENT/ ASSEMBLY	(3) MAINTENANCE FUNCTION	(4) MAINTENANCE LEVEL					(5) TOOLS AND EQUIPMENT REF CODE	(6) REMARKS CODE
			FIELD			SUSTAINMENT			
			CREW	SERVICE	FIELD	BELOW DEPOT	DEPOT		
			C	O	F	H	D		
0108	CRANKSHAFT ASSEM	Inspect Remove/Install Repair				0.3 6.0 6.0	1,5 3,4,5		
0111	GEAR CASE ASSEMBLY	Inspect Remove/Install Test Repair Overhaul			0.3 1.0	0.5 1.5 1.5 3.0	4 1,2,3,4 1,2,3,4		
02	COOLING SYSTEM	Inspect Service Repair		0.1 0. 0.			5 1,5		
0201	FAN ASSEMBLY	Inspect Remove/Install Replace		0. 0. 0.			1,5 1,5		
03	FUEL SYSTEM	Inspect Service Repair		0.1 0.	0.2 0. 1.		1,5 1,2,5		
0301	FUEL INJECTION ASSEMBLY	Inspect Test Remove/Install Replace Repair			0.2 0.2 0. 0.		0.2 0.2 0.6 0.6 3.0	1,5	
04	LUBRICATION SYSTEM	Inspect Service Repair		0. 0.2	0.1 0.		1,5 1,5		
0401	OIL PUMP ASSEMBLY	Inspect Remove/Install Replace				0.2 0.5 0.5	1,5 1,5		
0402	CRANKCASE ASSEMBLY	Inspect Remove/Install Repair			0. 1.0 0.		1,5 1,5		
05	EXHAUST SYSTEM	Inspect Remove/Install Replace		0.1	0.2 1. 1.		1,5 1,5		
0501	TURBOCHARGER ASSEMBLY	Inspect Test Remove/Install Replace Repair			0. 0.5 0. 1.		0.2 0.5 0.7 1.0 2.5	2 1,5 1,5 1,5	

MAC - Continued

Table 1. Maintenance Allocation Chart - Continued.

(1) GROUP NUMBER	(2) COMPONENT/ ASSEMBLY	(3) MAINTENANCE FUNCTION	(4) MAINTENANCE LEVEL					(5) TOOLS AND EQUIPMENT REF CODE	(6) REMARKS CODE
			FIELD			SUSTAINMENT			
			CREW	SERVICE	FIELD	BELOW DEPOT	DEPOT		
			C	O	F	H	D		
06	ELECTRICAL SYSTEM	Inspect Test			0.1 0.2			1	
0601	STARTER MOTOR ASSEMBLY	Inspect Test Remove/Install Replace		0.1 0.3 0.5 1.0				1 5 5	
0602	GENERATOR	Inspect Test Remove/Install Replace		0.1 0.3 0.5 2.				1 5 5	

TOOLS AND TEST EQUIPMENT REQUIREMENTS

Table 2. Tools and Test Equipment Requirements.

TOOL OR TEST EQUIPMENT REF CODE	MAINTENANCE LEVEL	NOMENCLATURE	NATIONAL STOCK NUMBER	TOOL NUMBER
1	F	Shop equipment, automotive maintenance and repair: field maintenance, supplemental set no. 2, less power	4910-00-754-0707	SC4910-95-CL-A63
2	O	Shop equipment, automotive maintenance and repair: organizational maintenance, common no. 1, less power	4910-00-754-0654	SC4910-95-CL-A74
3	F	Shop equipment, automotive vehicle	4910-01-490-6453	SC4910-95-A81
4	F	Shop equipment, fuel and electrical system engine: field maintenance, basic, less power	4940-00-754-0714	SC4910-95-CL-820
5	O	Tool kit, general mechanic's	5160-00-177-7033	SC5180-90-CL-N26
6	F	Tool set, basic, field maintenance	4910-00-754-0705	SC4910-95-CL-A31

REMARKS*Table 3. Remarks.*

REMARKS CODE	REMARKS
	NOT APPLICABLE.

**FIELD AND SUSTAINMENT LEVEL
DIESEL ENGINE, 4TNV84T-DFM
NSN 2815-01-538-4237
REPAIR PARTS AND SPECIAL TOOLS LIST
INTRODUCTION**

SCOPE

This RPSTL lists and authorizes spares and repair parts; special tools; special test, measurement, and diagnostic equipment (TMDE); and other special support equipment required for performance of field and sustainment level maintenance of diesel engine, model 4TNV84T-DFM. It authorizes the requisitioning, issue, and disposition of spares, repair parts, and special tools as indicated by the source, maintenance, and recoverability (SMR) codes.

GENERAL

In addition to the Introduction work package, this RPSTL is divided into the following work packages:

1. **Repair Parts List Work Packages.** Work packages containing lists of spares and repair parts authorized by this RPSTL for use in the performance of maintenance. These work packages also include parts which must be removed for replacement of the authorized parts. Parts lists are composed of functional groups in ascending alphanumeric sequence, with the parts in each group listed in ascending figure and item number sequence. Sending units, brackets, filters, and bolts are listed with the component they mount on. Bulk materials are listed by item name in FIG. BULK at the end of the work packages. Repair parts kits are listed separately in their own functional group and work package. Repair parts for repairable special tools are also listed in a separate work package. Items listed are shown on the associated illustrations.
2. **Special Tools List Work Packages.** Work packages containing lists of special tools, special TMDE, and special support equipment authorized by this RPSTL (as indicated by Basis of Issue (BOI) information in the DESCRIPTION AND USABLE ON CODE (UOC) column). Tools that are components of common tool sets and/or Class VII are not listed.
3. **Cross-Reference Indexes Work Packages.** There are three cross-reference indexes work packages in this RPSTL: the National Stock Number (NSN) Index work package, the Part Number (P/N) Index work package, and the Reference Designator Index work package. The National Stock Number Index work package refers you to the figure and item number. The Part Number Index work package refers you to the figure and item number. The Reference Designator Index work package refers you to the figure and item number.

EXPLANATION OF COLUMNS IN THE REPAIR PARTS LIST AND SPECIAL TOOLS LIST WORK PACKAGES

ITEM NO. (Column (1)). Indicates the number used to identify items called out in the illustration.

SMR CODE (Column (2)). The SMR code containing supply/requisitioning information, maintenance level authorization criteria, and disposition instruction, as shown in the following breakout:

<u>Source Code</u>	<u>Maintenance Code</u>	<u>Recoverability Code</u>
XX	XX	X
1st two positions: How to get an item.	3rd position: who can install, replace, or use the item.	4th position: Who can do complete repair* on the item
		5th position: Who determines disposition action on unserviceable items.

*Complete Repair: Maintenance capacity, capability, and authority to perform all corrective maintenance tasks of the Repair function in a use/user environment in order to restore serviceability to a failed item.

Source Code. The source code tells you how you get an item needed for maintenance, repair, or overhaul of an end item/equipment. Explanations of source codes follows:

<u>Source Code</u>	<u>Application/Explanation</u>
PA	Stock items; use the applicable NSN to requisition/request items with these source codes. They are authorized to the level indicated by the code entered in the 3rd position of the SMR code.
PB	
PC	
PD	
PE	
PF	
PG	
KD	Items coded PC are subject to deterioration.
KF	
KB	
MO-Made at unit/AVUM level	NOTE Items with these codes are not to be requested/requisitioned individually. They are part of a kit which is authorized to the maintenance level indicated in the 3rd position of the SMR code. The complete kit must be requisitioned and applied.
MF-Made at DS/AVIM level	
MH-Made at GS level	
ML-Made at SRA	
MD-Made at depot	Items with these codes are not to be requested/requisitioned individually. They must be made from bulk material which is identified by the P/N in the DESCRIPTION AND USABLE ON CODE (UOC) column and listed in the bulk material group work package of the RPSTL. If the item is authorized to you by the 3rd position code of the SMR code, but the source code indicates it is made at a higher level, order the item from the higher level of maintenance.

EXPLANATION OF COLUMNS IN THE REPAIR PARTS LIST AND SPECIAL TOOLS LIST WORK PACKAGES - Continued

<u>Source Code</u>	<u>Application/Explanation</u>
AO-Assembled by unit/AVUM level AF-Assembled by DS/AVIM level AH-Assembled by GS level AL-Assembled by SRA AD-Assembled by depot	Items with these codes are not to be requested/requisitioned individually. The parts that make up the assembled item must be requisitioned or fabricated and assembled at the level of maintenance indicated by the source code. If the 3rd position of the SMR code authorizes you to replace the item, but the source code indicates the item is assembled at a higher level, order the item from the higher level of maintenance.
XA	Do not requisition an "XA" code item. Order the next higher assembly. (Refer to the NOTE below.)
XB	If an item is not available from salvage, order it using the CAGEC and P/N.
XC	Installation drawings, diagrams, instruction sheets, field service drawings; identified by manufacturer's P/N.
XD	Item is not stocked. Order an "XD"-coded item through normal supply channels using the CAGEC and part number given, if no NSN is available.

NOTE

Cannibalization or controlled exchange, when authorized, may be used as a source of supply for items with the above source codes except for those source coded "XA" or those aircraft support items restricted by requirements of AR 750-1.

Maintenance Code. Maintenance codes tell you the level(s) of maintenance authorized to use and repair support items. The maintenance codes are entered in the third and fourth positions of the SMR code as follows:

Third Position. The maintenance code entered in the third position tells you the lowest maintenance level authorized to remove, replace, and use an item. The maintenance code entered in the third position will indicate authorization to the following levels of maintenance.

EXPLANATION OF COLUMNS IN THE REPAIR PARTS LIST AND SPECIAL TOOLS LIST WORK PACKAGES - Continued

<u>Maintenance Code</u>	<u>Application/Explanation</u>
C -	Crew or operator maintenance done within unit/AVUM maintenance.
O -	Unit level/AVUM maintenance can remove, replace, and use the item.
F -	Direct support/AVIM maintenance can remove, replace, and use the item.
H -	General support maintenance can remove, replace, and use the item.
L -	Specialized repair activity can remove, replace, and use the item.
D -	Depot can remove, replace, and use the item.

Fourth Position. The maintenance code entered in the fourth position tells you whether or not the item is to be repaired and identifies the lowest maintenance level with the capability to do complete repair (i.e., perform all authorized repair functions).

NOTE

Some limited repair may be done on the item at a lower level of maintenance, if authorized by the Maintenance Allocation Chart (MAC) and SMR codes.

<u>Maintenance Code</u>	<u>Application/Explanation</u>
O -	Unit/AVUM is the lowest level that can do complete repair of the item.
F -	Direct support/AVIM is the lowest level that can do complete repair of the item.
H -	General Support is the lowest level that can do complete repair of the item.
L -	Specialized repair activity is the lowest level that can do complete repair of the item.
D -	Depot is the lowest level that can do complete repair of the item.
Z -	Nonreparable. No repair is authorized.
B -	No repair is authorized. No parts or special tools are authorized for maintenance of a "B" coded item. However, the item may be reconditioned by adjusting, lubricating, etc., at the user level.

EXPLANATION OF COLUMNS IN THE REPAIR PARTS LIST AND SPECIAL TOOLS LIST WORK PACKAGES - Continued

Recoverability Code. Recoverability codes are assigned to items to indicate the disposition action on unserviceable items. The recoverability code is shown in the fifth position of the SMR code as follows:

<u>Recoverability Code</u>	<u>Application/Explanation</u>
Z -	Nonreparable item. When unserviceable, condemn and dispose of the item at the level of maintenance shown in 3d position of SMR Code.
O -	Reparable item. When not uneconomically repairable, condemn and dispose of the item at unit or AVUM level.
F -	Reparable item. When uneconomically repairable, condemn and dispose of the item at the direct support or AVIM level.
H -	Reparable item. When uneconomically repairable, condemn and dispose of the item at the general support level.
D -	Reparable item. When beyond lower level repair capability, return to depot. Condemnation and disposal of item not authorized below depot level.
L -	Reparable item. Condemnation and disposal not authorized below specialized repair activity (SRA).
A -	Item requires special handling or condemnation procedures because of specific reasons (e.g., precious metal content, high dollar value, critical material, or hazardous material). Refer to appropriate manuals/directives for specific instructions.

NSN (Column (3)). The NSN for the item is listed in this column.

CAGEC (Column (4)). The Commercial and Government Entity Code (CAGEC) is a five-digit code which is used to identify the manufacturer, distributor, or Government agency/activity that supplies the item.

PART NUMBER (Column (5)). Indicates the primary number used by the manufacturer (individual, company, firm, corporation, or Government activity), which controls the design and characteristics of the item by means of its engineering drawings, specifications, standards, and inspection requirements to identify an item or range of items.

EXPLANATION OF COLUMNS IN THE REPAIR PARTS LIST AND SPECIAL TOOLS LIST WORK PACKAGES - Continued

NOTE

When you use an NSN to requisition an item, the item you receive may have a different P/N from the number listed.

DESCRIPTION AND USABLE ON CODE (UOC) (Column (6)). This column includes the following information:

1. The federal item name, and when required, a minimum description to identify the item.
2. P/Ns of bulk materials are referenced in this column in the line entry to be manufactured or fabricated.
3. Hardness Critical Item (HCI). A support item that provides the equipment with special protection from electromagnetic pulse (EMP) damage during a nuclear attack.
4. The statement END OF FIGURE appears just below the last item description in column (6) for a given figure in both the repair parts list and special tools list work packages.

QTY (Column (7)). The QTY (quantity per figure) column indicates the quantity of the item used in the breakout shown on the illustration/figure, which is prepared for a functional group, subfunctional group, or an assembly. A appearing in this column instead of a quantity indicates that the quantity is variable and may vary from application to application.

EXPLANATION OF CROSS-REFERENCE INDEXES WORK PACKAGES FORMAT AND COLUMNS

1. National Stock Number (NSN) Index Work Package.

STOCK NUMBER Column. This column lists the NSN in National item identification number (NIIN) sequence. The NIIN consists of the last nine digits of the NSN.

$$\frac{\text{NSN}}{\text{NIIN}}$$
 (e.g., $\frac{5385-01-574-1476}{}$)

When using this column to locate an item, ignore the first four digits of the NSN. However, the complete NSN should be used when ordering items by stock number.

FIG. Column. This column lists the number of the figure where the item is identified/located. The figures are in numerical order in the repair parts list and special tools list work packages.

ITEM Column. The item number identifies the item associated with the figure listed in the adjacent FIG. column. This item is also identified by the NSN listed on the same line.

2. Part Number (P/N) Index Work Package. P/Ns in this index are listed in ascending alphanumeric sequence (vertical arrangement of letter and number combinations which places the first letter or digit of each group in order A thru Z, followed by the numbers 0 thru 9 and each following letter or digit in like order).

PART NUMBER Column. Indicates the P/N assigned to the item.

FIG. Column. This column lists the number of the figure where the item is identified/located in the repair parts list and special tools list work packages.

ITEM Column. The item number is the number assigned to the item as it appears in the figure referenced in the adjacent figure number column.

HOW TO LOCATE REPAIR PARTS

1. When NSNs or P/Ns Are Not Known.

First. Using the table of contents, determine the assembly group to which the item belongs. This is necessary since figures are prepared for assembly groups and subassembly groups, and lists are divided into the same groups.

Second. Find the figure covering the functional group or the subfunctional group to which the item belongs.

Third. Identify the item on the figure and note the number(s).

Fourth. Look in the repair parts list work packages for the figure and item numbers. The NSNs and part numbers are on the same line as the associated item numbers.

2. When NSN is Known.

First. If you have the NSN, look in the STOCK NUMBER column of the NSN index work package. The NSN is arranged in NIIN sequence. Note the figure and item number next to the NSN.

Second. Turn to the figure and locate the item number. Verify that the item is the one you are looking for.

3. When P/Ns is Known.

First. If you have the P/N and not the NSN, look in the PART NUMBER column of the P/N index work package. Identify the figure and item number.

Second. Look up the item on the figure in the applicable repair parts list work package.

ABBREVIATIONS

<u>Abbreviation</u>	<u>Explanation</u>
AVIM	Aviation Intermediate Maintenance
AVUM	Aviation Unit Maintenance
BOI	Basis of Issue
CAGEC	Commercial and Government Entity Code
EMP	Electromagnetic Pulse
KW	Kilowatt
MAC	Maintenance Allocation Chart
NIIN	National Item Identification Number
NSN	National Stock Number
OS	Oversize
SMR	Source, Maintenance, and Recoverability
SRA	Specialized Repair Activity
TMDE	Test, Measurement, and Diagnostic Equipment
UOC	Usable On Code

**FIELD AND SUSTAINMENT LEVEL
DIESEL ENGINE, 4TNV84T-DFM
NSN 2815-01-538-4237
TURBOCHARGED DIESEL ENGINE
REPAIR PARTS LIST**

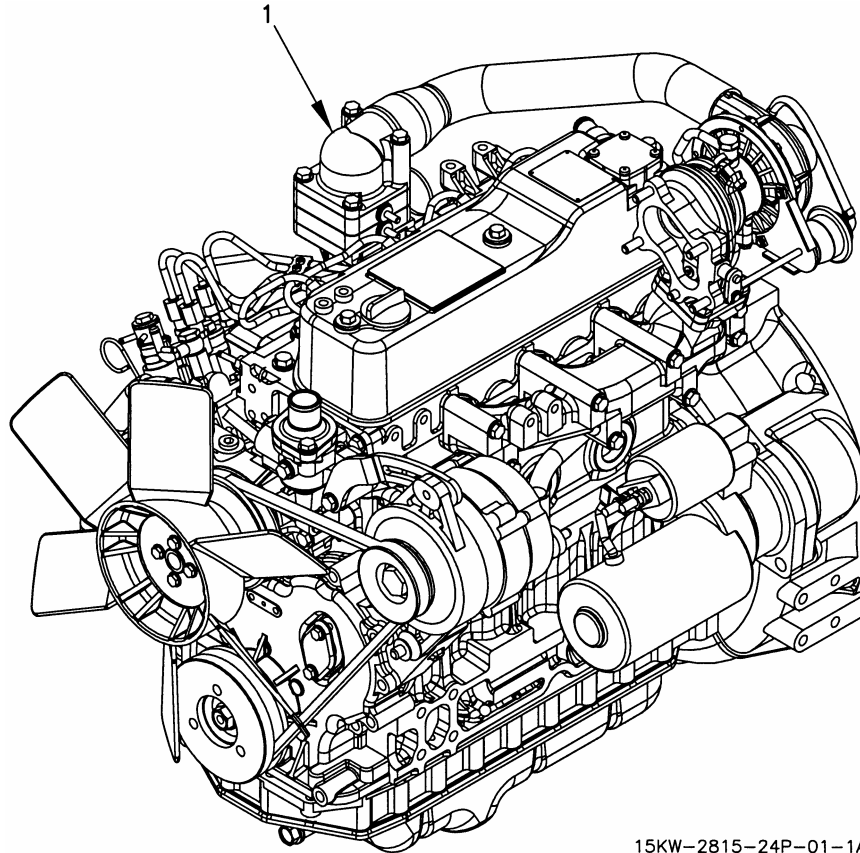

15KW-2815-24P-01-1A

Figure 1. Turbocharged Diesel Engine.

(1) ITEM NO.	(2) SMR CODE	(3) NSN	(4) CAGEC	(5) PART NUMBER	(6) DESCRIPTION AND USABLE ON CODE (UOC)	(7) QTY
					GROUP 00 ENGINE ASSEMBLY 15KW	
					FIG. 1. TURBOCHARGED DIESEL ENGINE	
1	PAFHH		0AK42	4TNV84T-DFM	DIESEL ENGINE, TURBOCHARGED, 4 CYLINDER	1
					END OF FIGURE	

**FIELD AND SUSTAINMENT LEVEL
DIESEL ENGINE, 4TNV84T-DFM
NSN 2815-01-538-4237
CYLINDER BLOCK ASSEMBLY
REPAIR PARTS LIST**

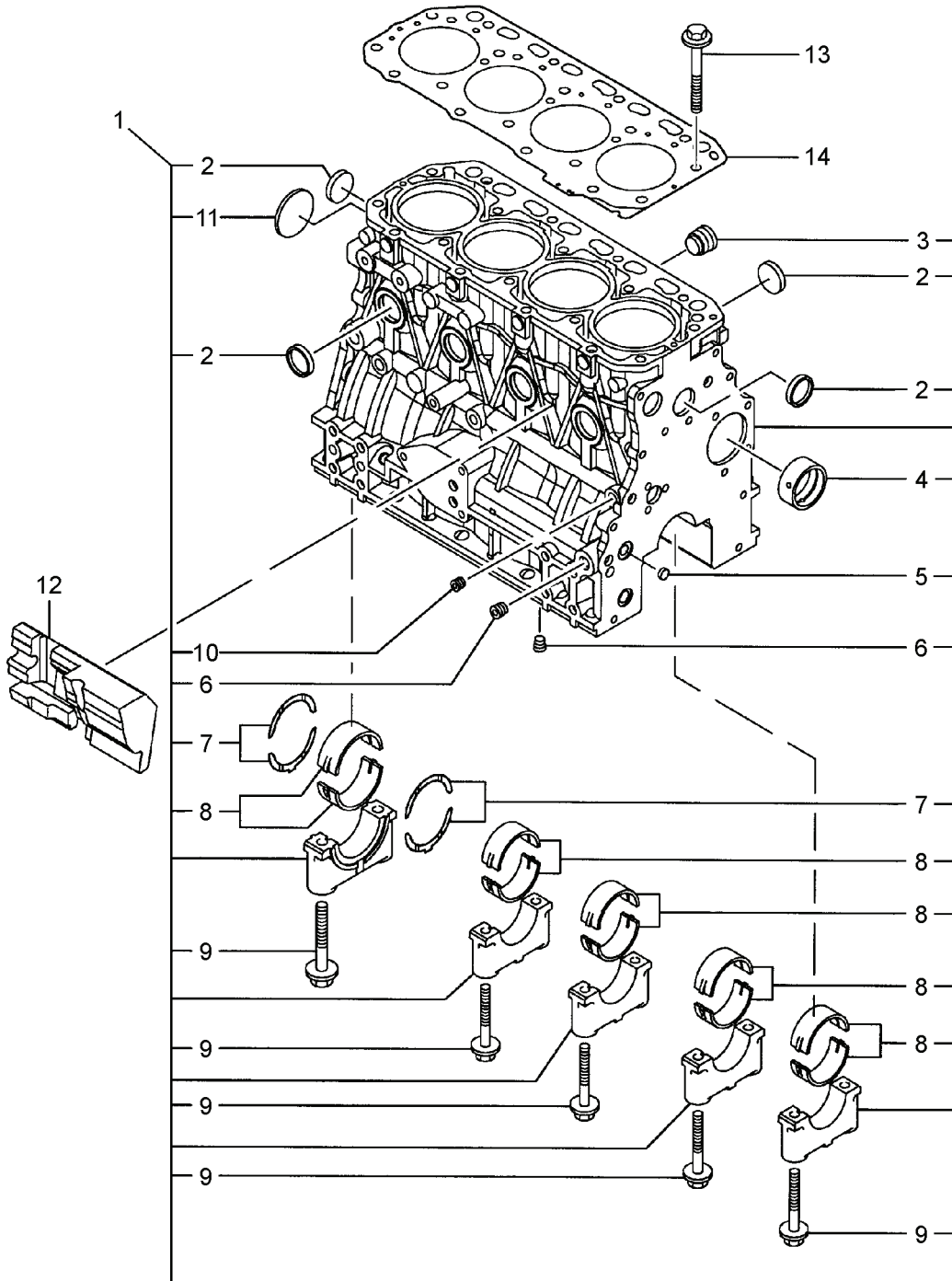

15KW-2815-24P-15

Figure 2. Cylinder Block Assembly.

(1) ITEM NO.	(2) SMR CODE	(3) NSN	(4) CAGEC	(5) PART NUMBER	(6) DESCRIPTION AND USABLE ON CODE (UOC)	(7) QTY
GROUP 01 ENGINE BLOCK ASSEMBLY						
FIG. 2. CYLINDER BLOCK ASSEMBLY						
1	XBHHH		0AK42	729508-01560	BLOCK ASSEMBLY, CYLINDER.....	1
2	XBHZZ		0AK42	27241-300000	PLUG.....	8
3	XBHZZ		0AK42	171051-01921	PLUG.....	1
4	PAHZZ	3120-99-549-3927	0AK42	129795-02411	BUSHING, CAMSHAFT.....	1
5	XBHZZ		0AK42	27241-120000	PLUG.....	2
6	XBHZZ		0AK42	124160-01910	PLUG.....	3
7	PAHZZ	3120-01-454-6117	0AK42	129150-02930	BEARING, HALF SET, SLEEVE.....	2
7	PAHZZ	3120-01-546-8931	0AK42	129150-02940	BEARING, HALF SET, SLEEVE.....	2
8	PAHZZ	3120-01-547-0495	0AK42	129001-02930	BEARING, HALF SET, SLEEVE.....	5
8	PAHZZ	3120-01-546-8480	0AK42	129150-02870	BEARING, HALF SET, SLEEVE.....	5
9	PAHZZ	5306-01-546-4269	0AK42	129150-02020	BOLT, MACHINE.....	10
10	XBHZZ		0AK42	124060-01050	PLUG.....	1
11	XBHZZ		0AK42	129001-01250	PLUG.....	1
12	PAFZZ		0AK42	129004-01190	SPACER, SPECIAL SHAPED.....	1
13	PAFZZ	5306-01-547-0465	0AK42	129150-01200	BOLT, MACHINE.....	18
14	PAFZZ	5330-01-546-7537	0AK42	129508-01330	GASKET, CYLINDER HEAD.....	1
END OF FIGURE						

**FIELD AND SUSTAINMENT LEVEL
DIESEL ENGINE, 4TNV84T-DFM
NSN 2815-01-538-4237
ROCKER ARM SHAFT ASSEMBLY
REPAIR PARTS LIST**

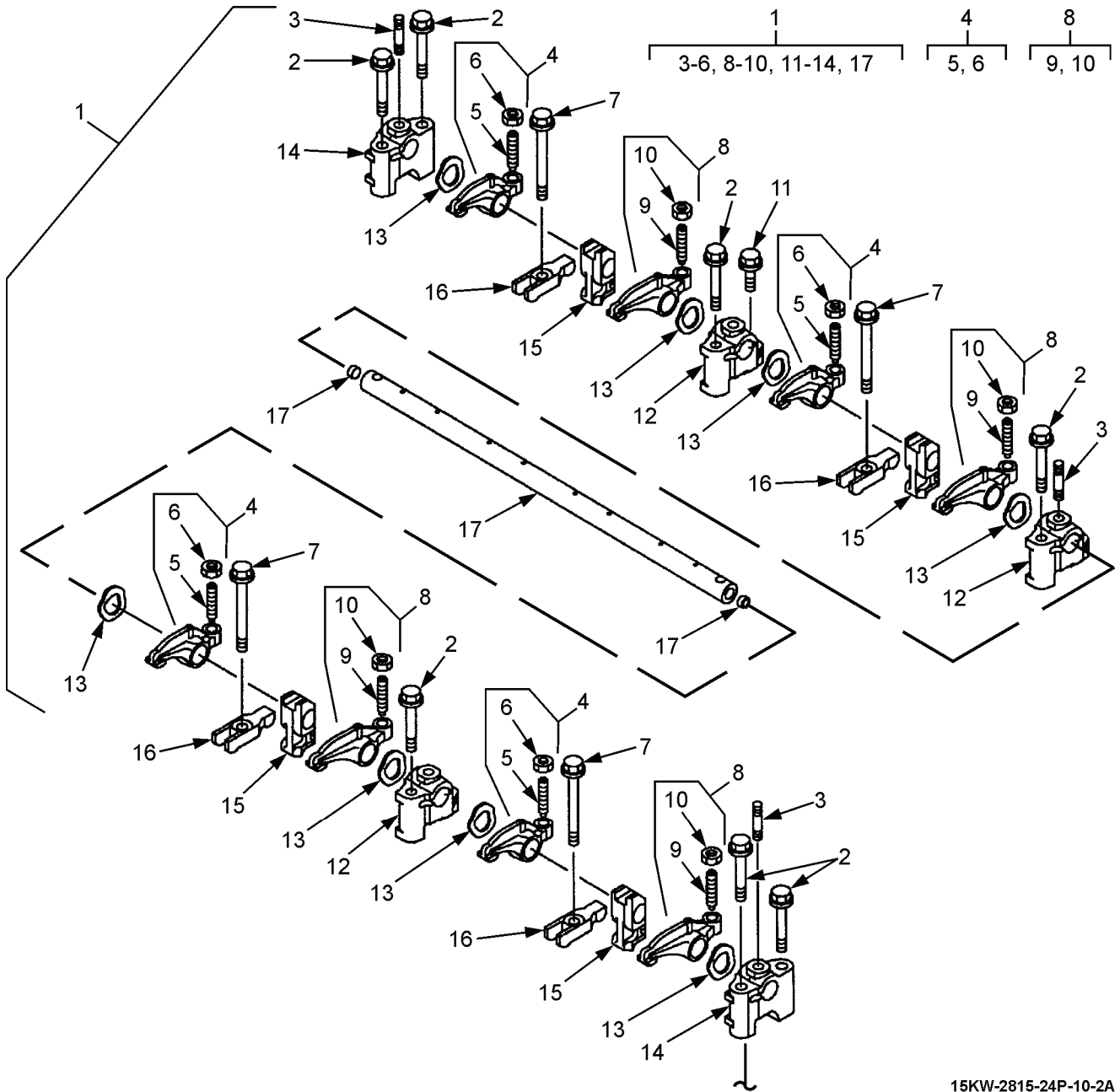

15KW-2815-24P-10-2A

Figure 3. Rocker Arm Shaft Assembly.

(1) ITEM NO.	(2) SMR CODE	(3) NSN	(4) CAGEC	(5) PART NUMBER	(6) DESCRIPTION AND USABLE ON CODE (UOC)	(7) QTY
					GROUP 0101 ROCKER ARM ASSEMBLY	
					FIG. 3. ROCKER ARM SHAFT ASSEMBLY	
1	XBHHH		0AK42	129508-11241	SHAFT ASSEMBLY, ROCKER.....	1
2	PAHZZ	5306-01-546-4263	0AK42	26106-080502	BOLT, MACHINE.....	7
3	PAHZZ	5307-01-547-0090	0AK42	26226-080352	STUD, THREADED.....	3
4	XBHHH		0AK42	129508-11660	ARM ASSEMBLY, ROCKER.....	4
5	PAHZZ	5315-01-546-8568	0AK42	129150-11230	SCREW, VALVE.....	1
6	PAHZZ	5310-01-546-8916	0AK42	129150-11750	NUT, PLAIN, HEXAGON HEAD.....	1
7	PAHZZ	5306-01-547-0595	0AK42	129907-11950	BOLT, MACHINE.....	4
8	XBHHH		0AK42	129508-11650	ARM ASSEMBLY, ROCKER.....	4
9	PAHZZ	5315-01-546-8568	0AK42	129150-11230	SCREW, VALVE.....	1
10	PAHZZ	5310-01-546-8916	0AK42	129150-11750	NUT, PLAIN, HEXAGON HEAD.....	1
11	PAHZZ	5306-01-547-2404	0AK42	26106-080252	BOLT, MACHINE.....	3
12	XBHZZ		0AK42	129508-11270	SUPPORT, ROCKER ARM.....	3
13	PAHZZ	5310-01-546-8918	0AK42	129508-11280	WASHER, SPECIAL.....	8
14	XBHZZ		0AK42	129508-11260	SUPPORT, ROCKER ARM.....	2
15	XBHZZ		0AK42	129508-11920	PEDESTAL, RETAINER.....	4
16	XBHZZ		0AK42	129508-11900	RETAINER, VALVE.....	4
17	XBHZZ		0AK42	129508-11250	SHAFT.....	1
					END OF FIGURE	

FIELD AND SUSTAINMENT LEVEL
 DIESEL ENGINE, 4TNV84T-DFM
 NSN 2815-01-538-4237
 CYLINDER HEAD ASSEMBLY
 REPAIR PARTS LIST

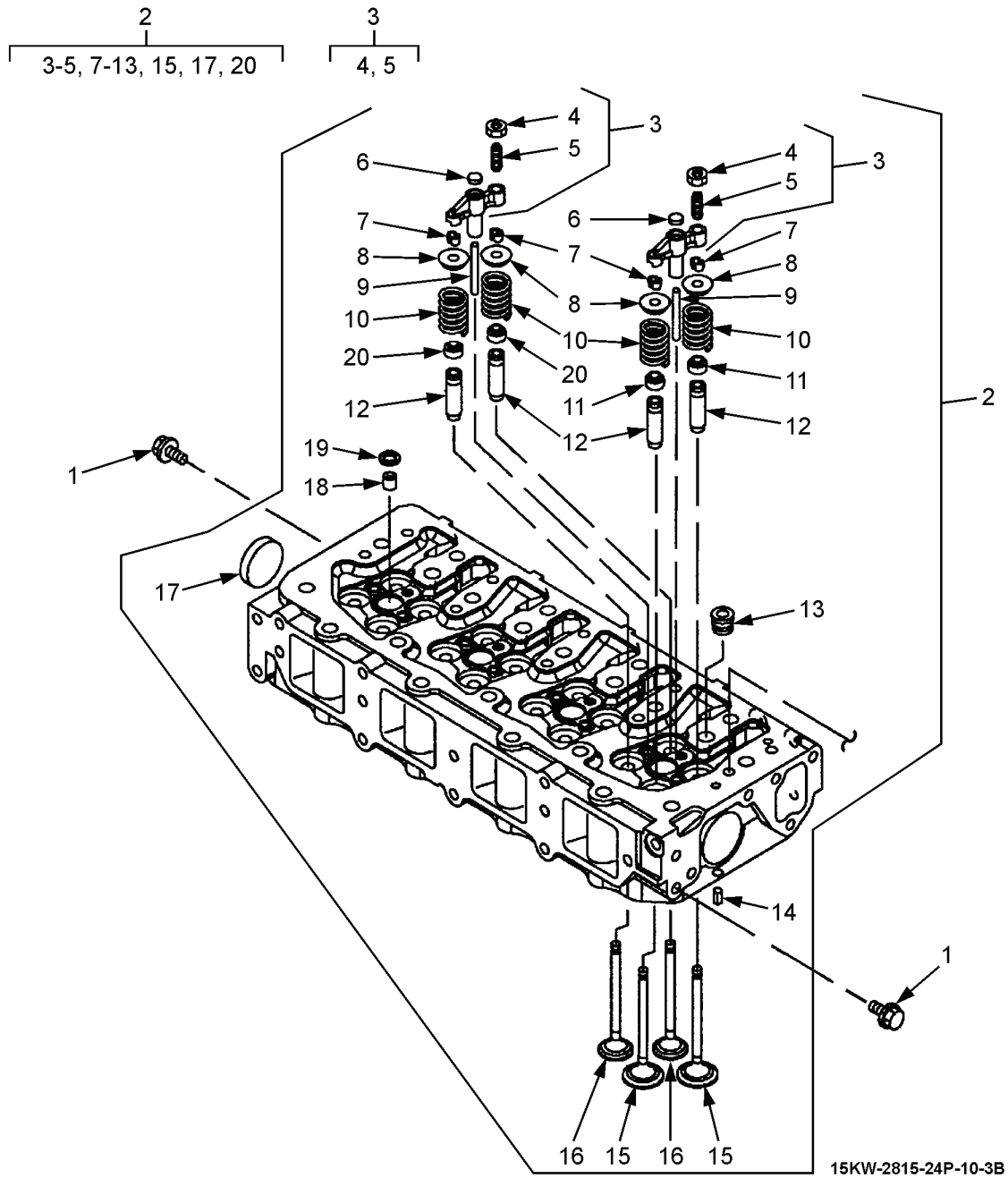
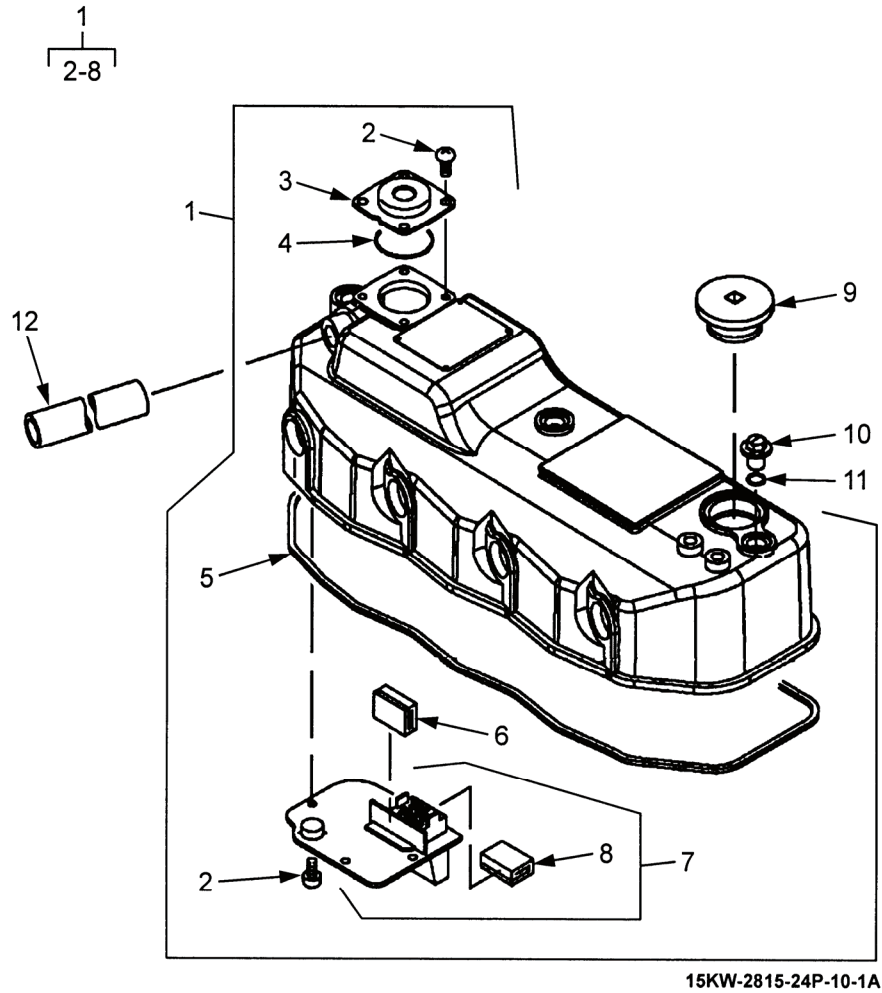

Figure 4. Cylinder Head Assembly.

(1) ITEM NO.	(2) SMR CODE	(3) NSN	(4) CAGEC	(5) PART NUMBER	(6) DESCRIPTION AND USABLE ON CODE (UOC)	(7) QTY
GROUP 0102 CYLINDER HEAD ASSEMBLY						
FIG. 4. CYLINDER HEAD ASSEMBLY						
1	PAFZZ	5306-01-546-8929	0AK42	26106-080142	BOLT, MACHINE.....	4
2	XBFHH	2815-01-538-0771	0AK42	129508-11700	HEAD ASSEMBLY, CYLINDER.....	1
3	XBHHH		0AK42	129508-11800	BRIDGE ASSEMBLY, VALVE.....	8
4	PAHZZ	5310-01-546-8916	0AK42	129150-11750	NUT, PLAIN, HEXAGON HEAD.....	1
5	PAHZZ	5305-01-546-8911	0AK42	123907-11830	SCREW, VALVE BRIDGE.....	1
6	PAHZZ	4820-01-546-4246	0AK42	129508-11840	SEAT, VALVE BRIDGE.....	8
7	PAHZZ	5365-01-547-0563	0AK42	119717-11190	COTTER, VALVE.....	32
8	PAHZZ	2815-01-546-4567	0AK42	129508-11180	RETAINER, SPRING.....	16
9	PAHZZ	5315-01-546-4572	0AK42	129508-11820	GUIDE, VALVE BRIDGE.....	2
10	PAHZZ	5360-01-547-0442	0AK42	129508-11130	SPRING, VALVE.....	16
11	PAHZZ	5330-01-546-8902	0AK42	119717-11340	SEAL, VALVE STEM.....	8
12	PAHZZ	2815-01-546-4327	0AK42	119717-11800	GUIDE, VALVE.....	16
13	XBFZZ	4730-01-546-4247	0AK42	23876-020000	PLUG.....	4
14	PAHZZ	5315-01-547-0091	0AK42	22351-060012	SPRING, PIN.....	2
15	PAHZZ	2815-01-546-9997	0AK42	129508-11100	VALVE, INTAKE.....	8
16	PAHZZ	4820-01-546-3548	0AK42	129508-11110	VALVE, EXHAUST.....	8
17	XBHZZ		0AK42	27241-400000	PLUG.....	2
18	PAFZZ	4720-01-546-3578	0AK42	119802-11870	PROTECTOR, NOZZLE.....	4
19	PAFZZ	2815-01-546-4587	0AK42	119625-11880	SEAT, NOZZLE.....	4
20	PAHZZ	5330-01-546-8128	0AK42	119717-11350	SEAL, VALVE STEM.....	8
END OF FIGURE						

FIELD AND SUSTAINMENT LEVEL
 DIESEL ENGINE, 4TNV84T-DFM
 NSN 2815-01-538-4237
 VALVE COVER ASSEMBLY
 REPAIR PARTS LIST



15KW-2815-24P-10-1A

Figure 5. Valve Cover Assembly.

(1) ITEM NO.	(2) SMR CODE	(3) NSN	(4) CAGEC	(5) PART NUMBER	(6) DESCRIPTION AND USABLE ON CODE (UOC)	(7) QTY
					GROUP 0103 VALVE COVER ASSEMBLY	
					FIG. 5. VALVE COVER ASSEMBLY	
1	XBFFF		0AK42	129508-11350	VALVE COVER ASSEMBLY	1
2	PAOZZ	5305-01-546-8629	0AK42	22857-500100	SCREW, TAPPING	8
3	XBOZZ		0AK42	129006-03120	COVER, DIAPHRAGM	1
4	PAOZZ	5331-01-546-4260	0AK42	24341-000400	O-RING	1
5	PAOZZ	5330-01-546-8924	0AK42	129508-11310	GASKET, BONNET	1
6	XBOZZ		0AK42	129150-03070	BAFFLE, BREATHER.....	1
7	XBOZZ		0AK42	129508-03010	PLATE, BAFFLE.....	1
8	XBOZZ		0AK42	119802-03070	BAFFLE, BREATHER.....	1
9	PAOZZ		0AK42	119807-11770	COVER, FILLER.....	1
10	PAOZZ	5355-01-546-9841	0AK42	124160-11360	KNOB.....	3
11	PAOZZ	5331-01-546-8517	0AK42	24311-000120	O-RING.....	3
12	XBOZZ		0AK42	129150-03090	ADAPTER, PIPE	1
					END OF FIGURE	

FIELD AND SUSTAINMENT LEVEL
 DIESEL ENGINE, 4TNV84T-DFM
 NSN 2815-01-538-4237
 CONNECTING ROD AND PISTON ASSEMBLY
 REPAIR PARTS LIST

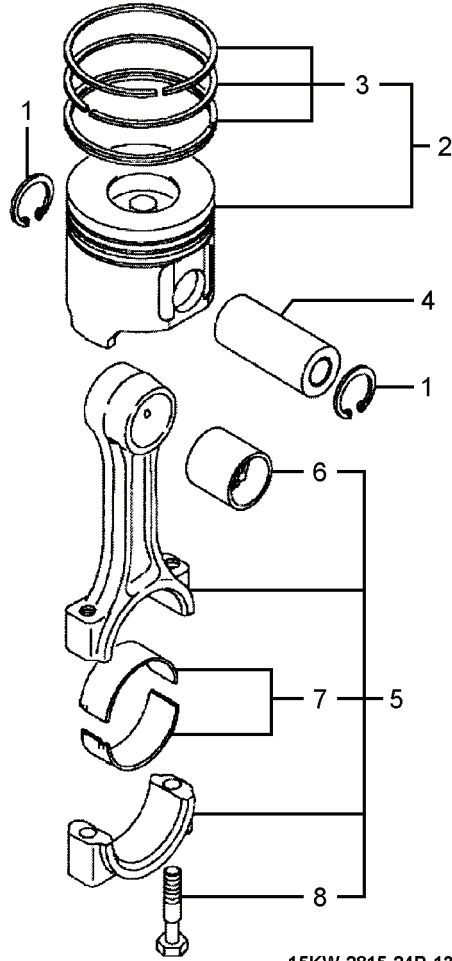

15KW-2815-24P-13

Figure 6. Connecting Rod and Piston Assembly.

(1) ITEM NO.	(2) SMR CODE	(3) NSN	(4) CAGEC	(5) PART NUMBER	(6) DESCRIPTION AND USABLE ON CODE (UOC)	(7) QTY
					GROUP 0104 CONNECTING ROD AND PISTON ASSEMBLY	
					FIG. 6. CONNECTING ROD AND PISTON ASSEMBLY	
1	PAHZZ	5340-01-546-6859	0AK42	22252-000260	CLIP, RETAINING.....	8
2	PBHHH	2815-01-538-0978	0AK42	129508-22080	PISTON ASSEMBLY.....	4
3	PAHZZ	2815-01-546-4717	0AK42	129004-22500	RING SET.....	4
3	PAHZZ	2815-01-546-8047	0AK42	129004-22950	RING SET OS-0.25.....	4
4	PAHZZ	2815-01-546-4721	0AK42	129202-22300	PIN, PISTON.....	4
5	PBHHH	2815-01-538-0835	0AK42	729402-23100	ROD ASSEMBLY, CONNECTING.....	4
6	PAHZZ	5365-01-546-8936	0AK42	129100-23910	BUSH, PISTON PIN.....	4
7	PAHZZ	3120-01-455-5082	0AK42	129150-23600	BEARING SLEEVE, HALF.....	4
7	PAHZZ	3120-01-546-9268	0AK42	129150-23610	BEARING, SLEEVE.....	4
8	PAHZZ	5306-01-546-4275	0AK42	121550-23200	BOLT, MACHINE.....	8
					END OF FIGURE	

**FIELD AND SUSTAINMENT LEVEL
DIESEL ENGINE, 4TNV84T-DFM
NSN 2815-01-538-4237
CAMSHAFT, DRIVING GEAR, AND IDLE GEAR ASSEMBLIES
REPAIR PARTS LIST**

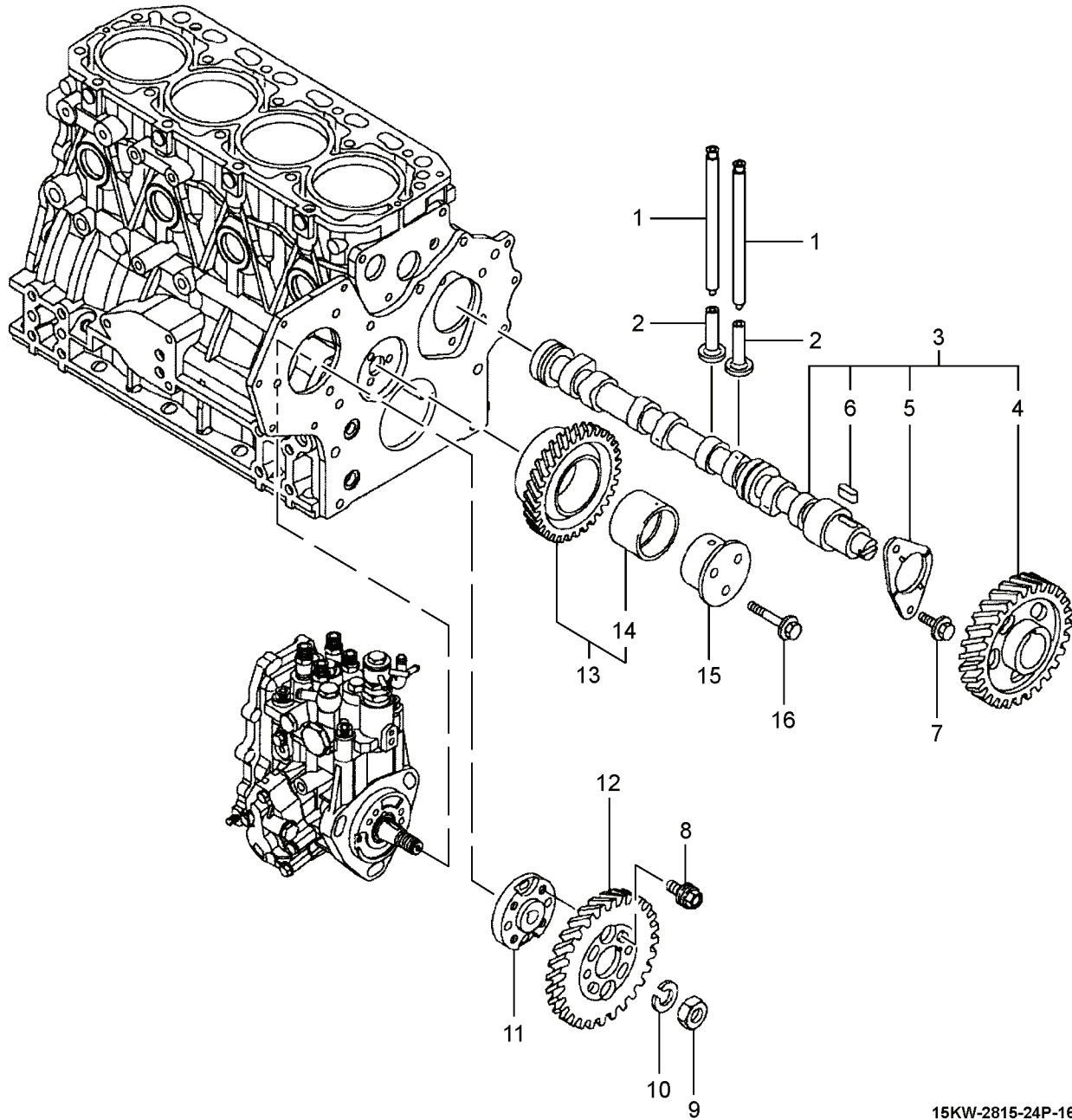

15KW-2815-24P-16

Figure 7. Camshaft, Driving Gear, and Idle Gear Assemblies.

(1) ITEM NO.	(2) SMR CODE	(3) NSN	(4) CAGEC	(5) PART NUMBER	(6) DESCRIPTION AND USABLE ON CODE (UOC)	(7) QTY
GROUP 0105 IDLE GEAR ASSEMBLY						
FIG. 7. CAMSHAFT, DRIVING GEAR, AND IDLE GEAR ASSEMBLIES						
1	PAHZZ	2920-01-546-4582	0AK42	129150-14400	ROD, PUSH.....	8
2	PAHZZ	2815-01-546-7688	0AK42	129150-14200	TAPPET.....	8
3	PBH HH	2815-01-538-0974	0AK42	129508-14580	CAMSHAFT ASSEMBLY	1
4	PAHZZ	3020-01-455-4443	0AK42	129150-14101	GEAR, HELICAL	1
5	PAHZA	2815-01-546-4309	0AK42	129150-02450	CAM, CONTROL	1
6	PAHZZ	5315-01-465-9931	0AK42	22512-070140	KEY, MACHINE.....	1
7	PAFZZ	5306-01-546-8929	0AK42	26106-080142	BOLT, MACHINE.....	2
8	PAHZZ	5306-01-546-4266	0AK42	129150-25301	BOLT, MACHINE.....	4
9	PAHZZ	5310-01-546-9272	0AK42	26776-140002	NUT, SELF-LOCKING.....	1
10	PAFZZ	5310-01-546-3576	0AK42	22217-140000	WASHER, SPRING.....	1
11	PAFZZ	3040-01-546-4092	0AK42	158552-51151	FLANGE	1
12	PAFZZ		0AK42	119802-25901	GEAR, PUMP	1
13	PAFH H	3020-01-538-0777	0AK42	119802-25100	GEAR ASSEMBLY, IDLE.....	1
14	PAFZZ	5365-01-547-0544	0AK42	119802-25070	BUSH, IDLE GEAR	1
15	XBFZZ		0AK42	119802-25051	SHAFT, IDLE GEAR.....	1
16	PAFZZ	5306-01-547-0081	0AK42	26106-080402	BOLT, MACHINE.....	3
END OF FIGURE						

**FIELD AND SUSTAINMENT LEVEL
DIESEL ENGINE, 4TNV84T-DFM
NSN 2815-01-538-4237
FLYWHEEL ASSEMBLY
REPAIR PARTS LIST**

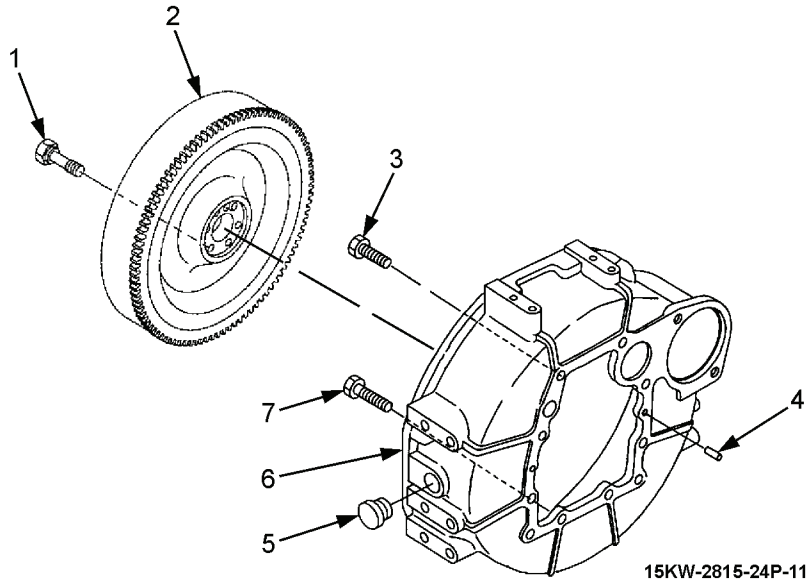

Figure 8. Flywheel Assembly.

(1) ITEM NO.	(2) SMR CODE	(3) NSN	(4) CAGEC	(5) PART NUMBER	(6) DESCRIPTION AND USABLE ON CODE (UOC)	(7) QTY
					GROUP 0107 FLYWHEEL HOUSING ASSEMBLY	
					FIG. 8. FLYWHEEL ASSEMBLY	
1	PAFZZ	5306-01-546-9973	0AK42	121111-21501	BOLT, MACHINE.....	6
2	XBFZZ		0AK42	129649-21590	FLYWHEEL	1
3	PAFZZ	5306-99-450-7012	0AK42	26206-100252	BOLT, MACHINE.....	6
4	PAFZZ	5315-01-546-9902	0AK42	129100-01580	PIN, PARALLEL	2
5	XBFZZ		0AK42	119620-01750	CAP, FLYWHEEL COVER.....	1
6	XBFZZ		0AK42	171420-01600	HOUSING, FLYWHEEL	1
7	PAFZZ	5306-01-431-7460	0AK42	26206-100302	BOLT, MACHINE.....	4
					END OF FIGURE	

**FIELD AND SUSTAINMENT LEVEL
DIESEL ENGINE, 4TNV84T-DFM
NSN 2815-01-538-4237
CRANKSHAFT ASSEMBLY
REPAIR PARTS LIST**

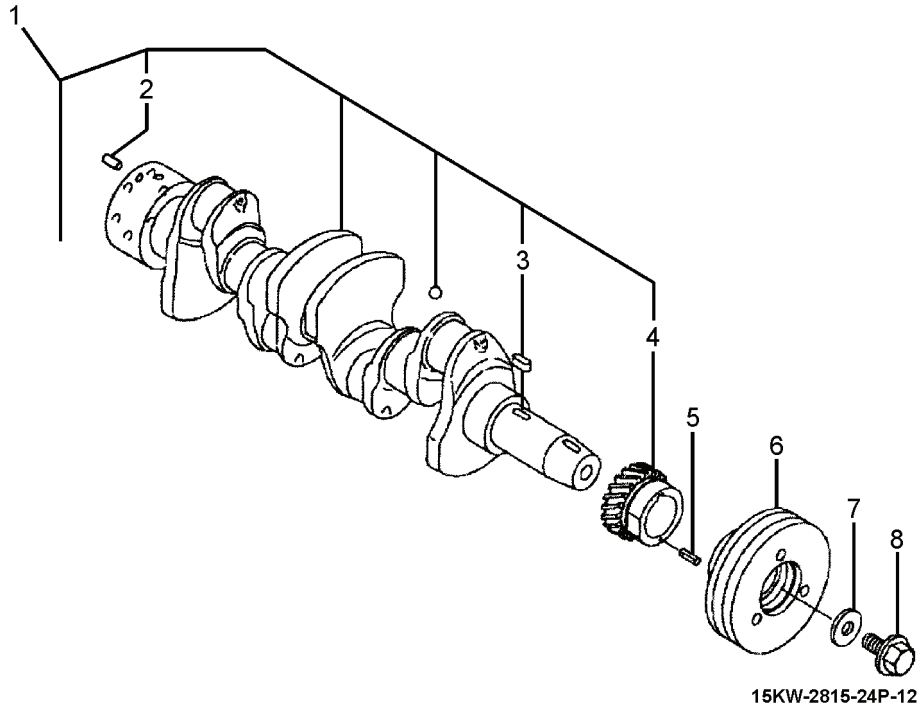
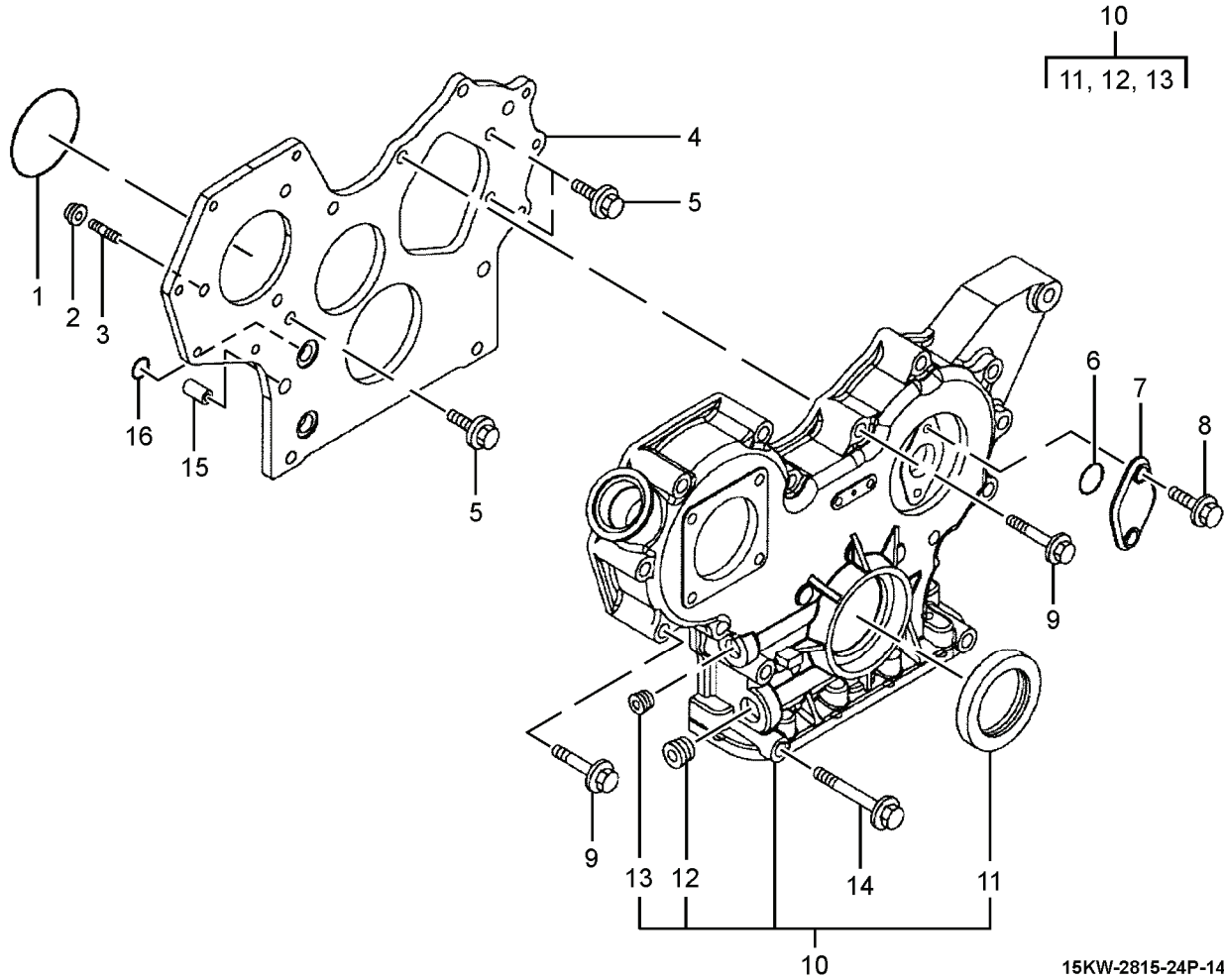

Figure 9. Crankshaft Assembly.

(1) ITEM NO.	(2) SMR CODE	(3) NSN	(4) CAGEC	(5) PART NUMBER	(6) DESCRIPTION AND USABLE ON CODE (UOC)	(7) QTY
					GROUP 0108 CRANKSHAFT ASSEMBLY	
					FIG. 9. CRANKSHAFT ASSEMBLY	
1	PBHHH	2815-01-537-9999	0AK42	129508-21002	CRANKSHAFT ASSEMBLY.....	1
2	PAHZZ	5315-01-546-9902	0AK42	129100-01580	PIN, PARALLEL.....	1
3	PAHZZ	5315-01-465-9931	0AK42	22512-070140	KEY, MACHINE.....	1
4	PAHZZ	3020-01-547-4629	0AK42	119802-21202	GEAR, CRANKSHAFT.....	1
5	PAHZZ	5315-01-546-8877	0AK42	22351-030010	PIN, SPRING.....	1
6	PAHZZ	3020-01-547-4625	0AK42	119802-21660	PULLEY, CRANKSHAFT.....	1
7	PAHZZ	5310-01-546-9888	0AK42	129795-21661	WASHER, FLAT.....	1
8	PAHZZ	5306-01-546-9891	0AK42	121850-21680	BOLT, MACHINE.....	1
					END OF FIGURE	

FIELD AND SUSTAINMENT LEVEL
DIESEL ENGINE, 4TNV84T-DFM
NSN 2815-01-538-4237
GEAR CASE ASSEMBLY
REPAIR PARTS LIST



15KW-2815-24P-14

Figure 10. Gear Case Assembly.

(1) ITEM NO.	(2) SMR CODE	(3) NSN	(4) CAGEC	(5) PART NUMBER	(6) DESCRIPTION AND USABLE ON CODE (UOC)	(7) QTY
GROUP 0111 GEAR CASE ASSEMBLY						
FIG. 10. GEAR CASE ASSEMBLY						
1	PAFZZ	5331-01-546-8510	0AK42	121850-51960	O-RING.....	1
2	PAFZZ	5310-01-546-8927	0AK42	26306-080002	NUT, PLAIN, HEXAGON HEAD.....	3
3	PAHZZ	5307-01-546-3559	0AK42	119802-01560	STUD, THREADED.....	3
4	XBHZZ		0AK42	119802-01520	FLANGE, GEAR CASE.....	1
5	PAFZZ	5305-01-158-0835	0AK42	26106-080162	SCREW, CAP, HEXAGON HEAD.....	3
6	PAFZZ	5331-01-546-4255	0AK42	24341-000240	O-RING.....	1
7	XBFFZZ		0AK42	121023-01550	COVER, BLIND.....	1
8	PAFZZ	5305-01-388-6229	0AK42	26106-060162	SCREW, CAP, HEXAGON HEAD.....	2
9	PAFZZ	5306-01-477-3508	0AK42	26106-080552	SCREW, CAP, HEXAGON HEAD.....	12
10	XBFFF		0AK42	129240-01500	CASE ASSEMBLY, GEAR.....	1
11	PAFZZ	5330-01-454-4380	0AK42	129795-01800	SEAL, OIL.....	1
12	XBHZZ		0AK42	23876-040000	PLUG.....	1
13	XBHZZ		0AK42	23876-030000	PLUG.....	1
14	PAFZZ	5306-01-547-0001	0AK42	129001-91841	BOLT, MACHINE.....	3
15	XBHZZ		0AK42	129795-01950	PIN, ALIGNMENT.....	2
16	PAHZZ	5331-01-547-0529	0AK42	119609-32040	O-RING.....	4
END OF FIGURE						

FIELD AND SUSTAINMENT LEVEL
DIESEL ENGINE, 4TNV84T-DFM
NSN 2815-01-538-4237
COOLING SYSTEM
REPAIR PARTS LIST

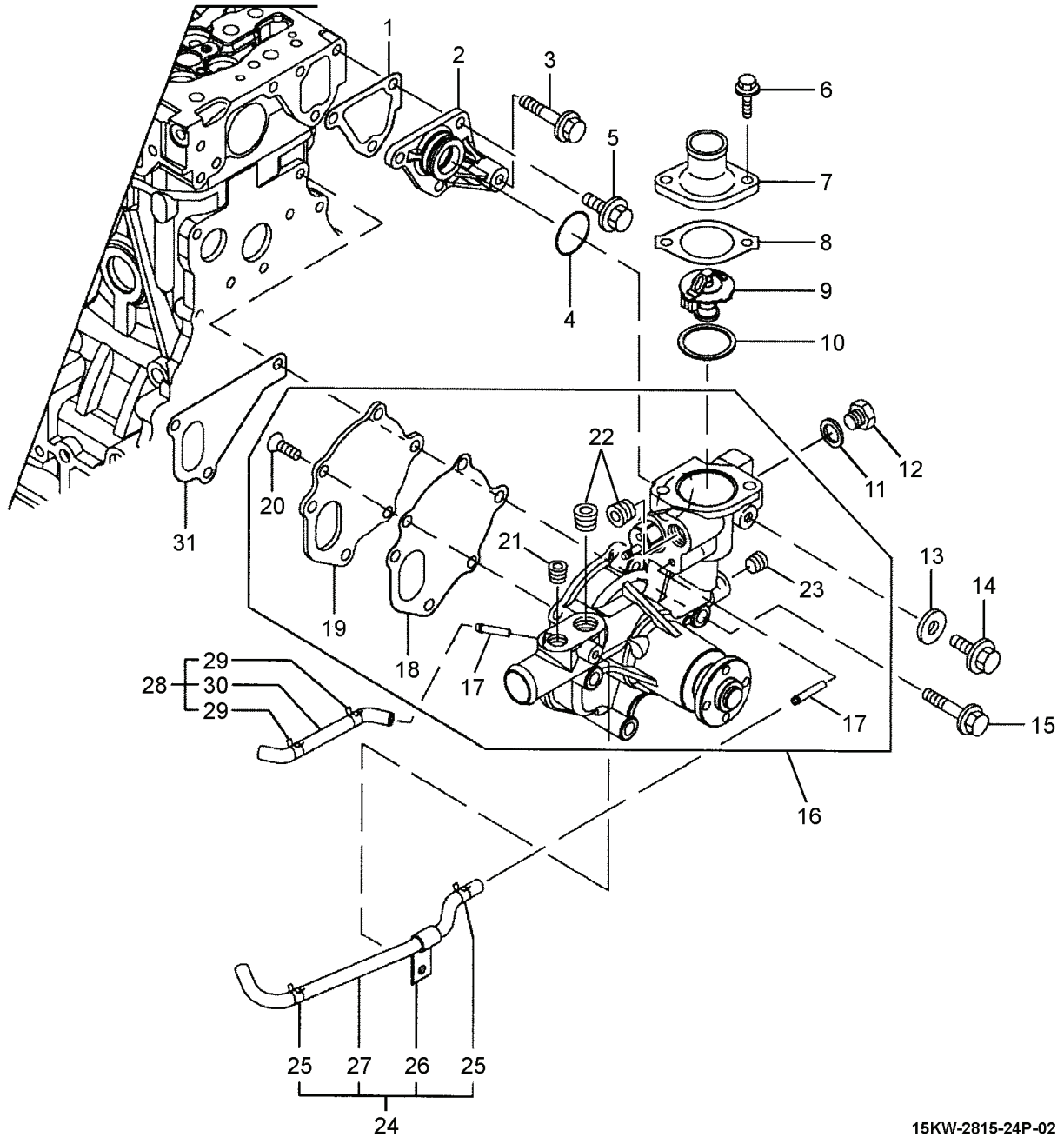

15KW-2815-24P-02

Figure 11. Cooling System.

(1) ITEM NO.	(2) SMR CODE	(3) NSN	(4) CAGEC	(5) PART NUMBER	(6) DESCRIPTION AND USABLE ON CODE (UOC)	(7) QTY
GROUP 02 COOLING SYSTEM						
FIG. 11. COOLING SYSTEM						
1	PAOZZ	5330-01-546-3538	0AK42	124395-49840	GASKET	1
2	XBOZZ		0AK42	129004-42040	ADAPTER, SPECIAL, THERMOSTAT CASE	1
3	PAFZZ	5306-01-388-6230	0AK42	26106-080452	BOLT, MACHINE	1
4	PAOZZ	5331-01-547-0466	0AK42	129486-42140	O-RING	1
5	PAFZZ	5305-01-158-0835	0AK42	26106-080162	SCREW, CAP, HEXAGON HEAD	3
6	PAOZZ	5306-01-546-8052	0AK42	26106-080222	BOLT, MACHINE	2
7	XBOZZ		0AK42	129350-49530	COVER, THERMOSTAT	1
8	PAOZZ	5330-99-727-8075	0AK42	129795-49551	GASKET	1
9	PAOZZ	6685-01-546-3005	0AK42	129155-49801	THERMOSTAT	1
10	PAOZZ	5330-01-547-0461	0AK42	129150-49811	GASKET	1
11	PAFZZ	5330-01-546-8898	0AK42	124465-44950	GASKET	2
12	PAOZZ	4730-01-546-4242	0AK42	121450-42450	PLUG	1
13	PAOZZ	5330-01-454-6389	0AK42	23414-080000	GASKET	1
14	PAFZZ	5305-14-469-7436	0AK42	26106-080122	BOLT, MACHINE	1
15	PAFZZ	5306-01-547-0515	0AK42	26106-080602	BOLT, MACHINE	3
16	PAOOO		0AK42	129508-42000	PUMP ASSEMBLY, COOLANT	1
17	PAOZZ	4730-01-546-9253	0AK42	119802-49113	PIPE, JOINT	2
18	PAOZZ	5330-01-547-0629	0AK42	129100-42051	GASKET	1
19	XBOZZ		0AK42	129100-42121	PLATE, COVER	1
20	PAOZZ	5305-01-546-8870	0AK42	121850-42410	SCREW, MACHINE	3
21	PAOZZ	4730-01-546-4247	0AK42	23876-020000	PLUG	1
22	PAOZZ	4730-01-546-8903	0AK42	129916-49740	PLUG, DRAIN	2
23	PAOZZ	5365-01-526-7332	0AK42	23876-010000	PLUG	1
24	AOOOO		0AK42	129004-49610	HOSE ASSEMBLY, NONMETALLIC	1
25	PAOZZ	5340-01-323-7844	0AK42	124722-59050	CLAMP, HOSE	2
26	PAOZZ	5340-01-546-8917	0AK42	119802-49730	CLAMP, LOOP	1
27	PAOZZ	4720-01-546-8893	0AK42	129004-49711	HOSE, NONMETALLIC	1
28	AOOOO		0AK42	129004-49620	HOSE ASSEMBLY, NONMETALLIC	1
29	PAOZZ	5340-01-323-7844	0AK42	124722-59050	CLAMP, HOSE	2
30	PAOZZ	4720-01-546-8124	0AK42	129004-49721	HOSE, NONMETALLIC	1
31	PAOZZ	5330-01-546-8895	0AK42	129486-42021	GASKET	1
END OF FIGURE						

**FIELD AND SUSTAINMENT LEVEL
DIESEL ENGINE, 4TNV84T-DFM
NSN 2815-01-538-4237
FAN ASSEMBLY
REPAIR PARTS LIST**

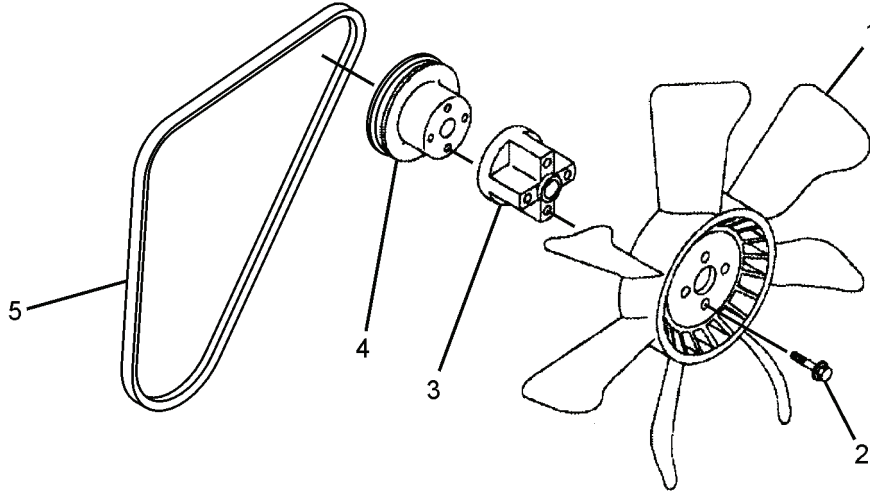

15KW-2815-24P-32

Figure 12. Fan Assembly.

(1) ITEM NO.	(2) SMR CODE	(3) NSN	(4) CAGEC	(5) PART NUMBER	(6) DESCRIPTION AND USABLE ON CODE (UOC)	(7) QTY
					GROUP 0201 FAN ASSEMBLY	
					FIG. 12. FAN ASSEMBLY	
1	PAOZZ	2930-01-546-7913	0AK42	129110-44740	FAN, COOLING.....	1
2	PAOZZ	5306-01-546-8910	0AK42	26106-060402	BOLT, MACHINE.....	4
3	XBOZZ		0AK42	171353-44760	SPACER, FAN.....	1
4	XBOZZ		0AK42	129155-42350	PULLEY, BELT.....	1
5	PAOZZ	3030-01-547-4661	0AK42	25132-003800	BELT, V.....	1
					END OF FIGURE	

**FIELD AND SUSTAINMENT LEVEL
DIESEL ENGINE, 4TNV84T-DFM
NSN 2815-01-538-4237
FUEL SYSTEM
REPAIR PARTS LIST**

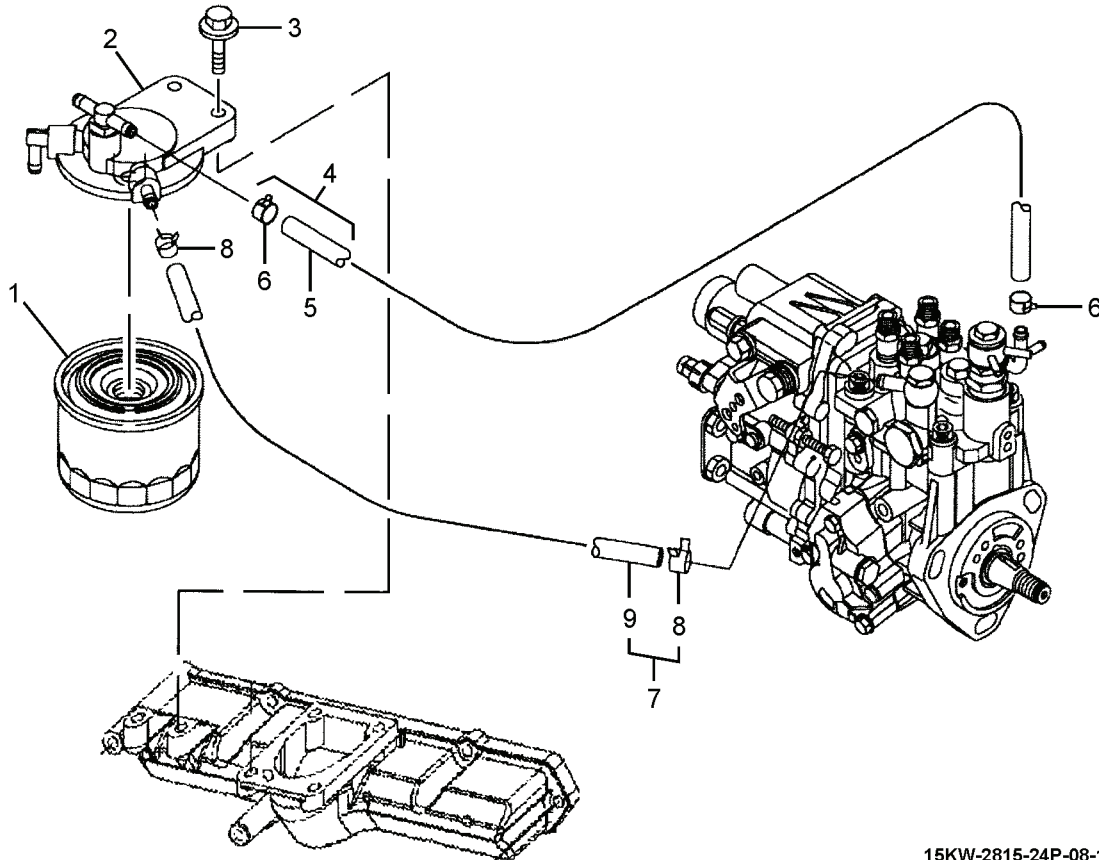

15KW-2815-24P-08-1

Figure 13. Fuel System.

(1) ITEM NO.	(2) SMR CODE	(3) NSN	(4) CAGEC	(5) PART NUMBER	(6) DESCRIPTION AND USABLE ON CODE (UOC)	(7) QTY
GROUP 03 FUEL SYSTEM						
FIG. 13. FUEL SYSTEM						
1	PAOZZ	2910-01-546-4727	0AK42	119802-55800	FILTER, FUEL	1
2	XBOZZ		0AK42	129004-55610	BRACKET, FUEL FILTER	1
3	PAFZZ	5306-01-546-8037	0AK42	26106-080302	BOLT, MACHINE	2
4	AOOOO		0AK42	129210-59160	HOSE ASSEMBLY, NONMETALLIC	1
5	PAOZZ	4720-01-546-8050	0AK42	129612-59520	HOSE, NONMETALLIC	1
6	PAOZZ	4730-01-546-8975	0AK42	124766-59050	CLAMP, HOSE	2
7	AOOOO		0AK42	129210-59110	HOSE ASSEMBLY, NONMETALLIC	1
8	PAOZZ	4730-01-546-8975	0AK42	124766-59050	CLAMP, HOSE	2
9	PAOZZ	4720-01-546-6890	0AK42	105025-59560	HOSE, NONMETALLIC	1
END OF FIGURE						

FIELD AND SUSTAINMENT LEVEL
 DIESEL ENGINE, 4TNV84T-DFM
 NSN 2815-01-538-4237
 FUEL INJECTION VALVE SYSTEM
 REPAIR PARTS LIST

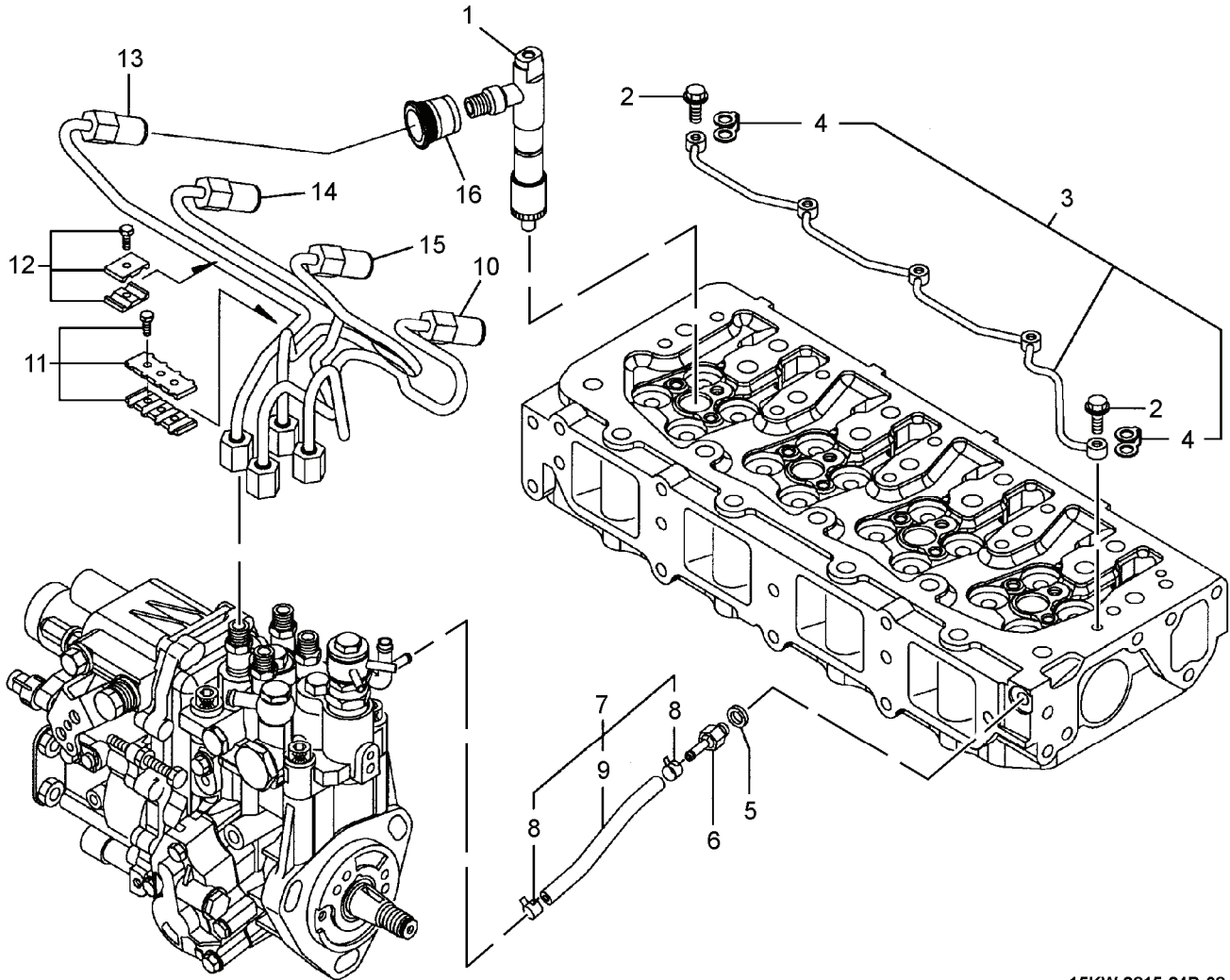

15KW-2815-24P-08-2B

Figure 14. Fuel Injection Valve System.

(1) ITEM NO.	(2) SMR CODE	(3) NSN	(4) CAGEC	(5) PART NUMBER	(6) DESCRIPTION AND USABLE ON CODE (UOC)	(7) QTY
GROUP 03 FUEL SYSTEM						
FIG. 14. FUEL INJECTION VALVE SYSTEM						
1	PAFZZ	2915-01-546-8222	0AK42	729508-53100	INJECTOR, FUEL	4
2	PAFZZ	5306-01-546-3527	0AK42	123907-59540	BOLT, MACHINE.....	5
3	PAFZZ	4710-01-546-8886	0AK42	129508-59550	PIPE ASSEMBLY, FUEL RETURN.....	1
4	PAFZZ	5330-01-546-8883	0AK42	123907-59550	PACKING, FUEL RETURN	5
5	PAFZZ	5310-01-546-8875	0AK42	22190-080002	SEAL, WASHER.....	1
6	PAFZZ	4730-01-546-9935	0AK42	123907-59560	ADAPTER, HOSE JOINT	1
7	AFFFF		0AK42	129508-59570	HOSE ASSEMBLY, NONMETALLIC	1
8	PAFZZ	5340-01-323-7844	0AK42	124722-59050	CLAMP, HOSE	2
9	PAFZZ	4720-01-546-7874	0AK42	129508-59510	HOSE, NONMETALLIC.....	1
10	PAFZZ	4710-01-546-4254	0AK42	129508-59940	PIPE ASSEMBLY, FUEL INJECTION.....	1
11	PAFZZ	5340-01-546-3539	0AK42	129550-59120	CLAMP, RETAINER	1
12	PAFZZ	5340-01-547-0471	0AK42	119305-59120	CLAMP, RETAINER	2
13	PAFZZ	4710-01-546-4250	0AK42	129508-59910	PIPE ASSEMBLY, FUEL INJECTION.....	1
14	PAFZZ	4710-01-546-9905	0AK42	129508-59920	PIPE ASSEMBLY, FUEL INJECTION.....	1
15	PAFZZ	4710-01-546-3530	0AK42	129508-59930	PIPE ASSEMBLY, FUEL INJECTION.....	1
16	PAFZZ	5330-01-546-9903	0AK42	123907-11601	SEAL, FUEL PIPE.....	4
END OF FIGURE						

**FIELD AND SUSTAINMENT LEVEL
DIESEL ENGINE, 4TNV84T-DFM
NSN 2815-01-538-4237
FUEL INJECTION ASSEMBLY
REPAIR PARTS LIST**

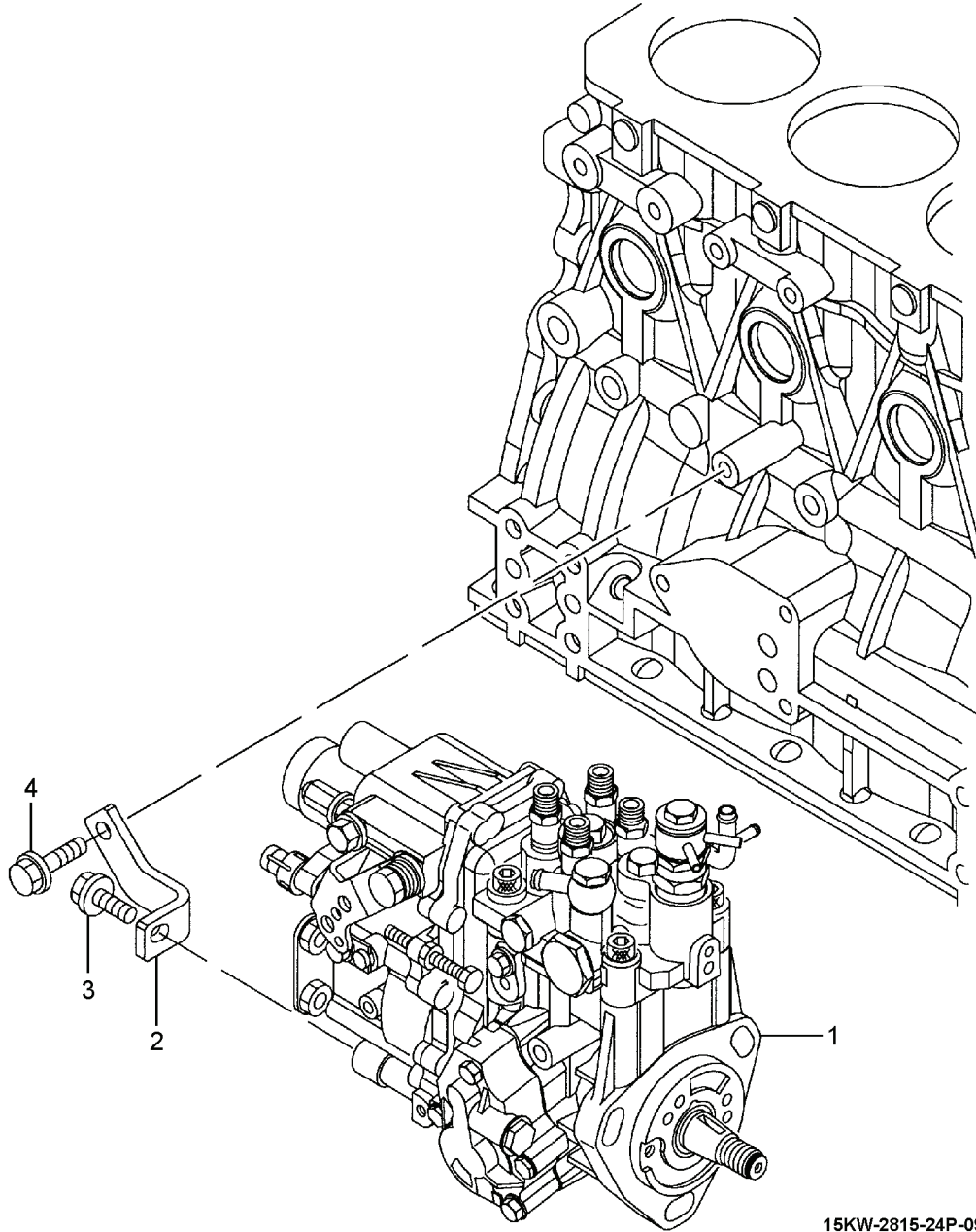

15KW-2815-24P-09

Figure 15. Fuel Injection Assembly.

(1) ITEM NO.	(2) SMR CODE	(3) NSN	(4) CAGEC	(5) PART NUMBER	(6) DESCRIPTION AND USABLE ON CODE (UOC)	(7) QTY
					GROUP 0301 FUEL INJECTION ASSEMBLY	
					FIG. 15. FUEL INJECTION ASSEMBLY	
1	PBFHH	2910-01-538-0115	0AK42	729508-51310	FUEL INJECTION ASSEMBLY.....	1
2	XBFZZ		0AK42	129508-51250	BRACKET, MOUNTING.....	1
3	PAFZZ	5306-01-546-8913	0AK42	26106-080202	BOLT, MACHINE.....	1
4	PAFZZ	5306-01-546-8037	0AK42	26106-080302	BOLT, MACHINE.....	1
					END OF FIGURE	

FIELD AND SUSTAINMENT LEVEL
 DIESEL ENGINE, 4TNV84T-DFM
 NSN 2815-01-538-4237
 OIL FILTER AND OIL COOLER
 REPAIR PARTS LIST

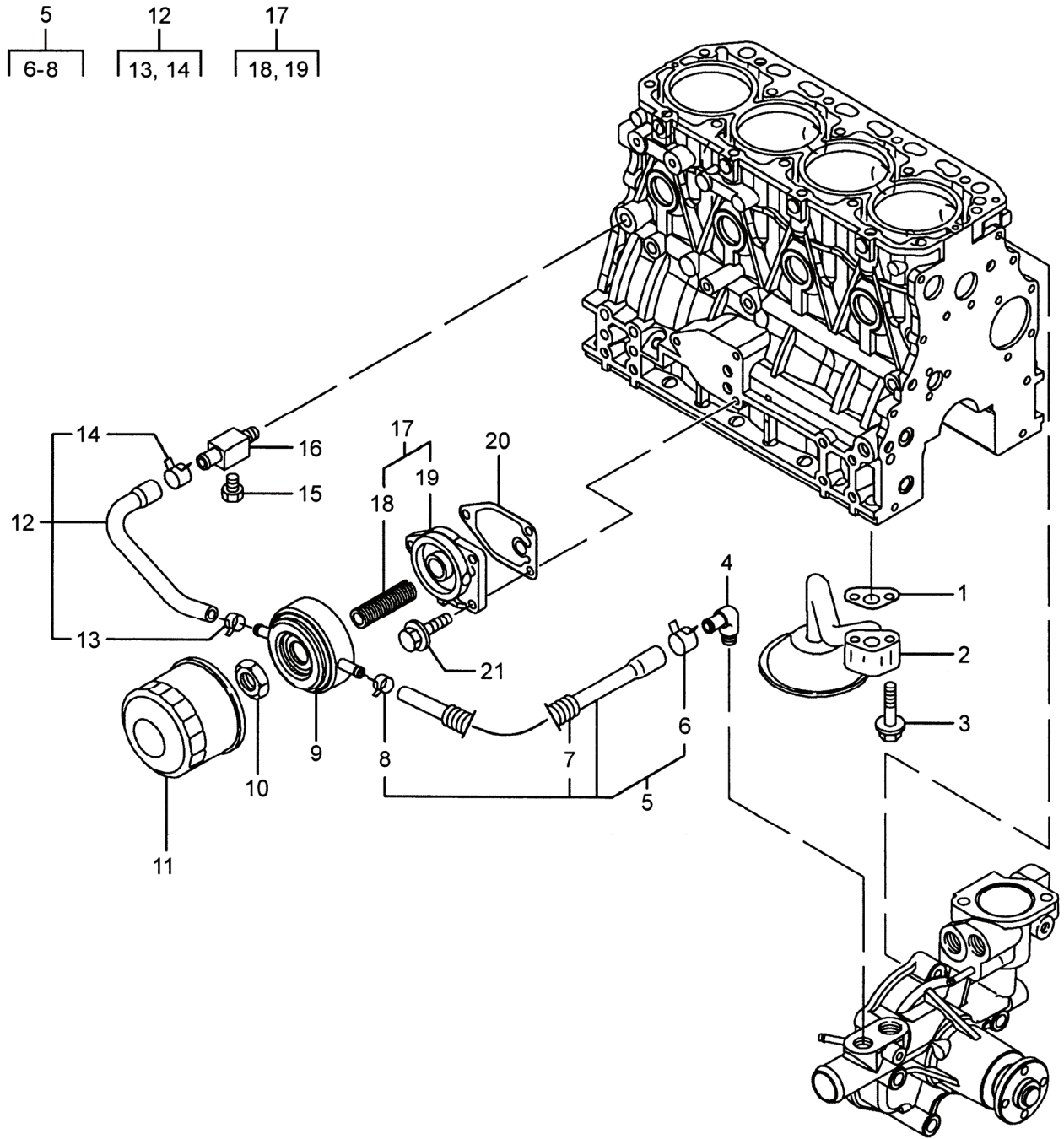

15KW-2815-24P-RL-07-1B

Figure 16. Oil Filter and Oil Cooler.

(1) ITEM NO.	(2) SMR CODE	(3) NSN	(4) CAGEC	(5) PART NUMBER	(6) DESCRIPTION AND USABLE ON CODE (UOC)	(7) QTY
GROUP 04 LUBRICATION SYSTEM						
FIG. 16. OIL FILTER AND OIL COOLER						
1	PAHZZ	5330-01-546-6844	0AK42	129150-35042	GASKET	1
2	XBHZZ		0AK42	129150-35091	PIPE, METAL	1
3	PAHZZ	5306-01-431-7461	0AK42	26106-080352	BOLT, MACHINE.....	2
4	PAOZZ	4730-01-546-8861	0AK42	129103-49301	ELBOW, PIPE TO TUBE.....	1
5	PAOZZ	4720-01-546-8868	0AK42	129508-49040	HOSE, NONMETALLIC.....	1
6	PAOZZ	4730-01-546-9221	0AK42	23080-018000	CLAMP, HOSE	1
7	PAOZZ	3120-01-546-8851	0AK42	119940-59130	COVER, PIPE PROTECTOR.....	1
8	PAOZZ	4730-01-546-7538	0AK42	23080-015000	CLAMP, HOSE	1
9	PAFZZ	2930-01-546-8053	0AK42	129508-33010	COOLER ASSEMBLY, OIL	1
10	PAFZZ	5310-01-546-8881	0AK42	129417-33110	NUT, PLAIN, HEXAGON HEAD	1
11	PAOZZ	2940-01-546-5058	0AK42	129150-35152	FILTER, OIL COOLER	1
12	PAOZZ	4720-01-546-8857	0AK42	129508-49030	HOSE, NONMETALLIC	1
13	PAOZZ	4730-01-546-7538	0AK42	23080-015000	CLAMP, HOSE	1
14	PAOZZ	4730-01-546-8864	0AK42	171008-03990	CLAMP, HOSE	1
15	PAOZZ	5365-01-546-9878	0AK42	171056-49120	PLUG, DRAIN	1
16	PAOZZ	4730-01-546-4701	0AK42	129006-44480	ADAPTER, SPECIAL, OIL COOLER	1
17	XBFFF		0AK42	129006-35100	BRACKET ASSEMBLY, FILTER	1
18	PAFZZ	5307-01-547-0405	0AK42	129417-35150	STUD, THREADED	1
19	XBFZZ		0AK42	119802-35110	BRACKET, FILTER	1
20	PAFZZ	5330-01-546-7545	0AK42	129150-35111	GASKET	1
21	PAFZZ	5306-01-546-8913	0AK42	26106-080202	BOLT, MACHINE	3
END OF FIGURE						

FIELD AND SUSTAINMENT LEVEL
 DIESEL ENGINE, 4TNV84T-DFM
 NSN 2815-01-538-4237
 OIL BYPASS VALVE
 REPAIR PARTS LIST

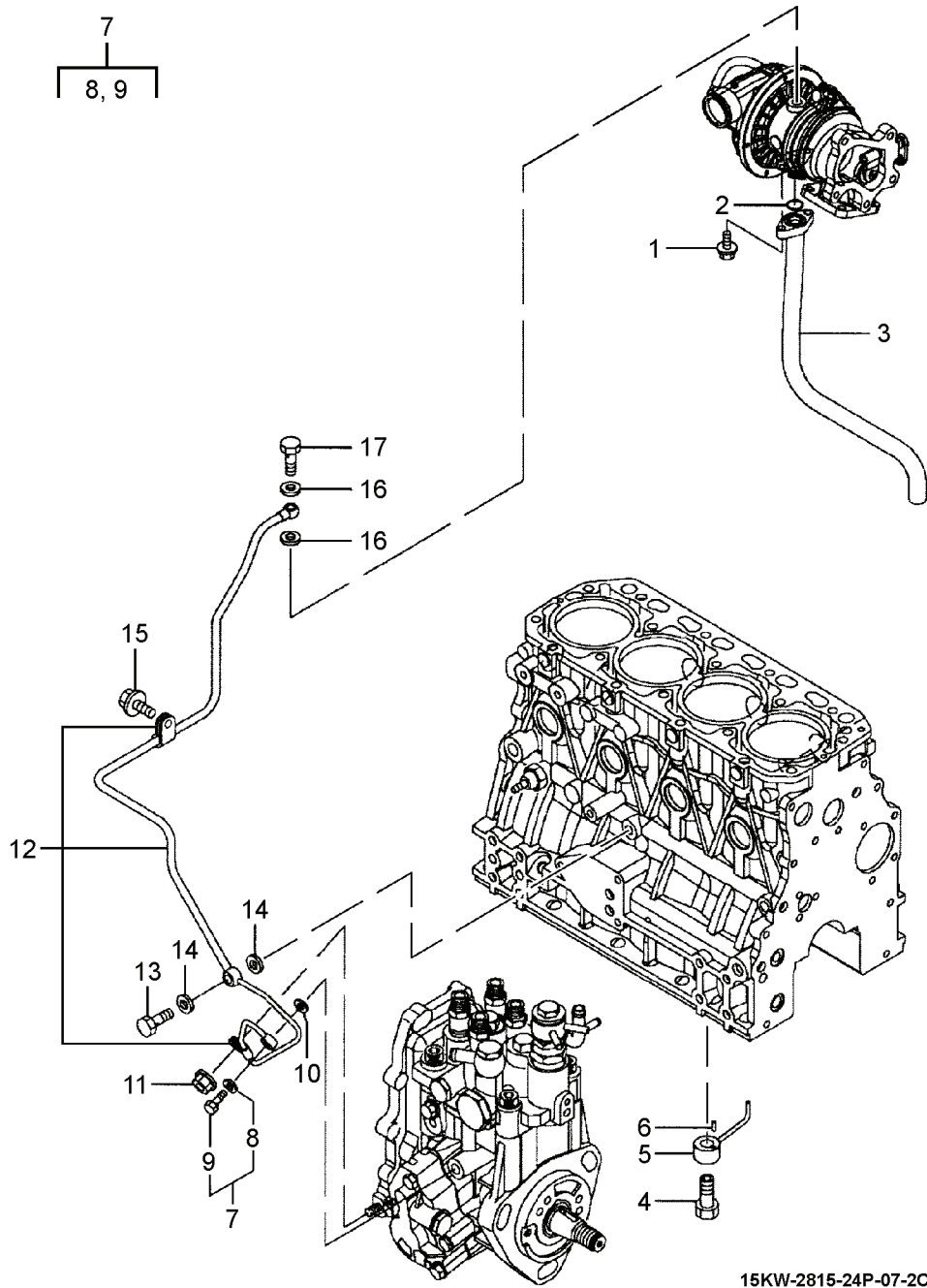
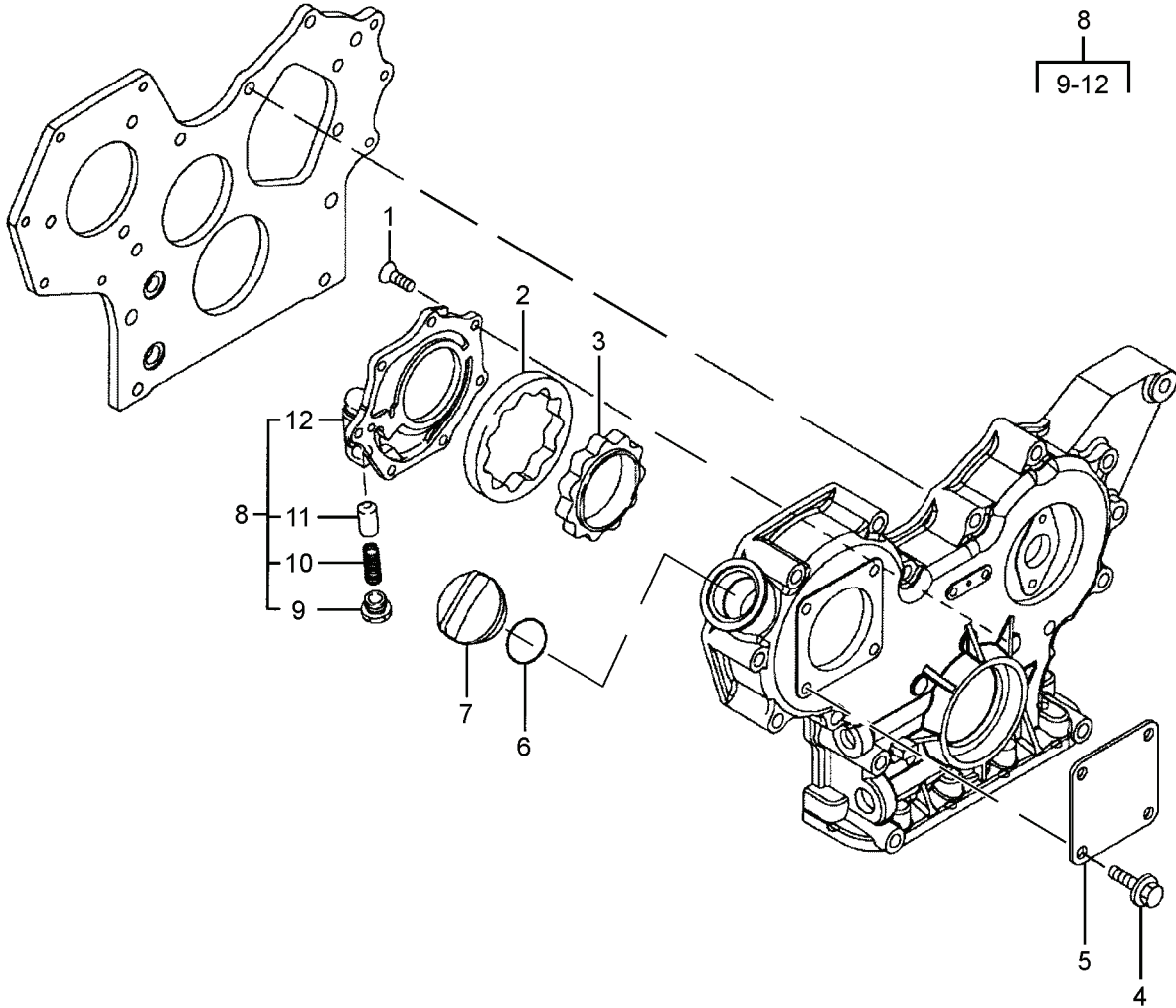

Figure 17. Oil Bypass Valve.

(1) ITEM NO.	(2) SMR CODE	(3) NSN	(4) CAGEC	(5) PART NUMBER	(6) DESCRIPTION AND USABLE ON CODE (UOC)	(7) QTY
GROUP 04 LUBRICATION SYSTEM						
FIG. 17. OIL BYPASS VALVE						
1	PAFZZ	5305-01-388-6229	0AK42	26106-060162	SCREW, CAP, HEXAGON HEAD	2
2	PAFZZ	5331-01-546-8932	0AK42	24314-000160	O-RING	1
3	XBFZZ		0AK42	129508-39600	TUBE, OIL RETURN	1
4	PAHZZ	4810-01-546-8874	0AK42	129792-39410	VALVE ASSEMBLY, CHECK	4
5	PAHZZ	2835-01-546-7876	0AK42	129553-39650	NOZZLE, LUBRICATING	4
6	PAHZZ	5315-01-546-8877	0AK42	22351-030010	PIN, SPRING	4
7	XBFZZ		0AK42	129005-59830	BOLT ASSEMBLY, JOINT	1
8	PAFZZ	5310-01-546-8875	0AK42	22190-080002	SEAL, WASHER	1
9	PAFZZ	5306-01-546-9263	0AK42	23857-030000	BOLT, MACHINE	1
10	PAFZZ	5310-01-546-8875	0AK42	22190-080002	SEAL, WASHER	1
11	PAFZZ	5310-01-388-8826	0AK42	26366-060002	NUT, PLAIN, HEXAGON HEAD	1
12	PAFZZ	4710-01-546-9222	0AK42	129508-39450	PIPE ASSEMBLY, OIL	1
13	PAFZZ	5306-01-546-9886	0AK42	124160-39140	BOLT, MACHINE	1
14	PAFZZ	5310-01-546-9316	0AK42	22190-100002	SEAL, WASHER	2
15	PAFZZ	5305-14-469-7436	0AK42	26106-080122	BOLT, MACHINE	1
16	PAFZZ	5330-01-546-8869	0AK42	23414-100000	GASKET	2
17	PAFZZ	5306-01-529-1138	0AK42	121252-39150	BOLT, MACHINE	1
END OF FIGURE						

FIELD AND SUSTAINMENT LEVEL
 DIESEL ENGINE, 4TNV84T-DFM
 NSN 2815-01-538-4237
 OIL PUMP ASSEMBLY
 REPAIR PARTS LIST



15KW-2815-24P-07-4B

Figure 18. Oil Pump Assembly.

(1) ITEM NO.	(2) SMR CODE	(3) NSN	(4) CAGEC	(5) PART NUMBER	(6) DESCRIPTION AND USABLE ON CODE (UOC)	(7) QTY
GROUP 0401 OIL PUMP ASSEMBLY						
FIG. 18. OIL PUMP ASSEMBLY						
1	PAHZZ	5305-01-546-8908	0AK42	119802-32130	SCREW, MACHINE	7
2	PAHZZ	3020-01-547-4658	0AK42	129508-32120	ROTOR, OUTER	1
3	PAHZZ	3020-01-546-8538	0AK42	129508-32111	ROTOR, INNER	1
4	PAFZZ	5305-01-158-0835	0AK42	26106-080162	SCREW, CAP, HEXAGON HEAD	4
5	XBFZZ		0AK42	124240-01871	COVER	1
6	PAOZZ	5331-01-546-8126	0AK42	24311-000320	O-RING	1
7	PAOZZ	2590-01-546-4329	0AK42	124160-01751	COVER, FILLER	1
8	PAHZZ	5340-01-546-4256	0AK42	119802-32100	COVER ASSEMBLY, PUMP	1
9	XAHZZ		0AK42	129001-32330	PLUG	1
10	XAHZZ		0AK42	129418-32320	SPRING	1
11	XAHZZ		0AK42	129900-32130	VALVE, RELIEF	1
12	XAHZZ		0AK42	119802-32070	COVER, LUBE OIL PUMP	1
END OF FIGURE						

FIELD AND SUSTAINMENT LEVEL
 DIESEL ENGINE, 4TNV84T-DFM
 NSN 2815-01-538-4237
 CRANKCASE ASSEMBLY
 REPAIR PARTS LIST

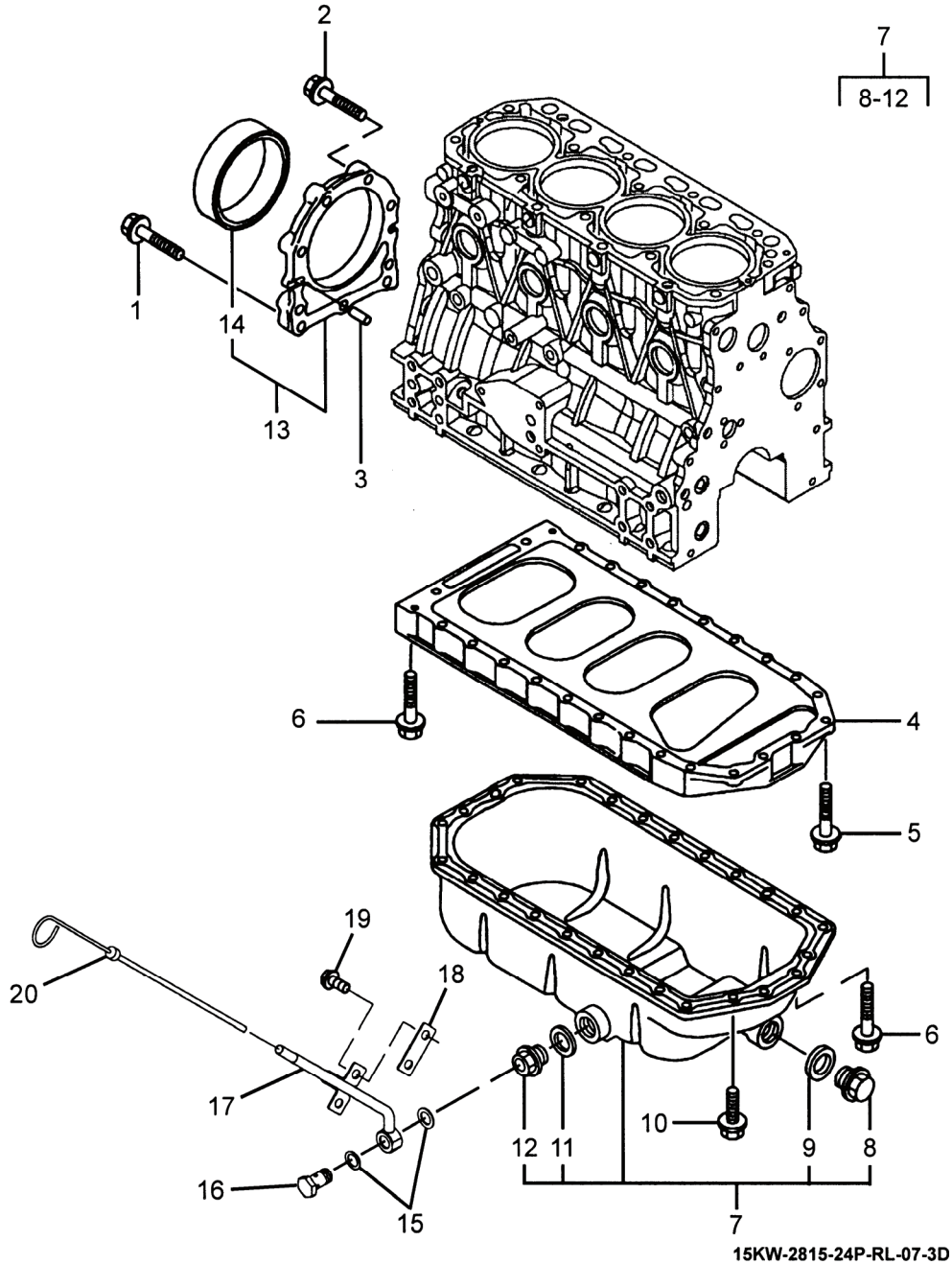

15KW-2815-24P-RL-07-3D

Figure 19. Crankcase Assembly.

(1) ITEM NO.	(2) SMR CODE	(3) NSN	(4) CAGEC	(5) PART NUMBER	(6) DESCRIPTION AND USABLE ON CODE (UOC)	(7) QTY
GROUP 0402 CRANKCASE ASSEMBLY						
FIG. 19. CRANKCASE ASSEMBLY						
1	PAHZZ	5306-01-431-7461	0AK42	26106-080352	BOLT, MACHINE	3
2	PAFZZ	5306-01-546-8899	0AK42	129486-01670	BOLT, MACHINE	6
3	PAFZZ	5315-01-546-9902	0AK42	129100-01580	PIN, PARALLEL	2
4	XBFZZ		0AK42	129400-01730	SPACER, STRAIGHT	1
5	PAHZZ	5306-01-547-2404	0AK42	26106-080252	BOLT, MACHINE	2
6	PAFZZ	5306-01-388-6230	0AK42	26106-080452	BOLT, MACHINE	24
7	PBFZZ	2815-01-546-8227	0AK42	129489-01770	OIL PAN	1
8	PAFZZ	4730-01-322-4956	0AK42	105425-01690	PLUG, PIPE	1
9	PAFZZ	5330-01-326-2669	0AK42	22190-160002	GASKET	1
10	PAFZZ	5305-01-158-0835	0AK42	26106-080162	SCREW, CAP, HEXAGON HEAD	4
11	PAOZZ		0AK42	22190-220002	SEAL, WASHER	1
12	PAOZZ		00U12	BELFER3	PLUG, DRAIN	1
13	XBFFF		0AK42	129100-01640	CASE ASSEMBLY, OIL SEAL	1
14	PAFZZ	5330-01-454-4384	0AK42	129795-01780	SEAL, PLAIN	1
15	PAOZZ		0AK42	22190-140002	SEAL, WASHER	2
16	PAOZZ		0AK42	23857-080000	PLUG, OIL	1
17	XBOZZ		00U12	BELFER2	GUIDE, DIPSTICK	1
18	XBOZZ		30554	97-24115	SPACER, DIPSTICK	1
19	PADZZ		30554	88-20260-32	BOLT, MACHINE	2
20	PAOZZ		00U12	BELFER1	GAGE, ROD, LIQUID LEVEL	1
END OF FIGURE						

FIELD AND SUSTAINMENT LEVEL
DIESEL ENGINE, 4TNV84T-DFM
NSN 2815-01-538-4237
INTAKE MANIFOLD
REPAIR PARTS LIST

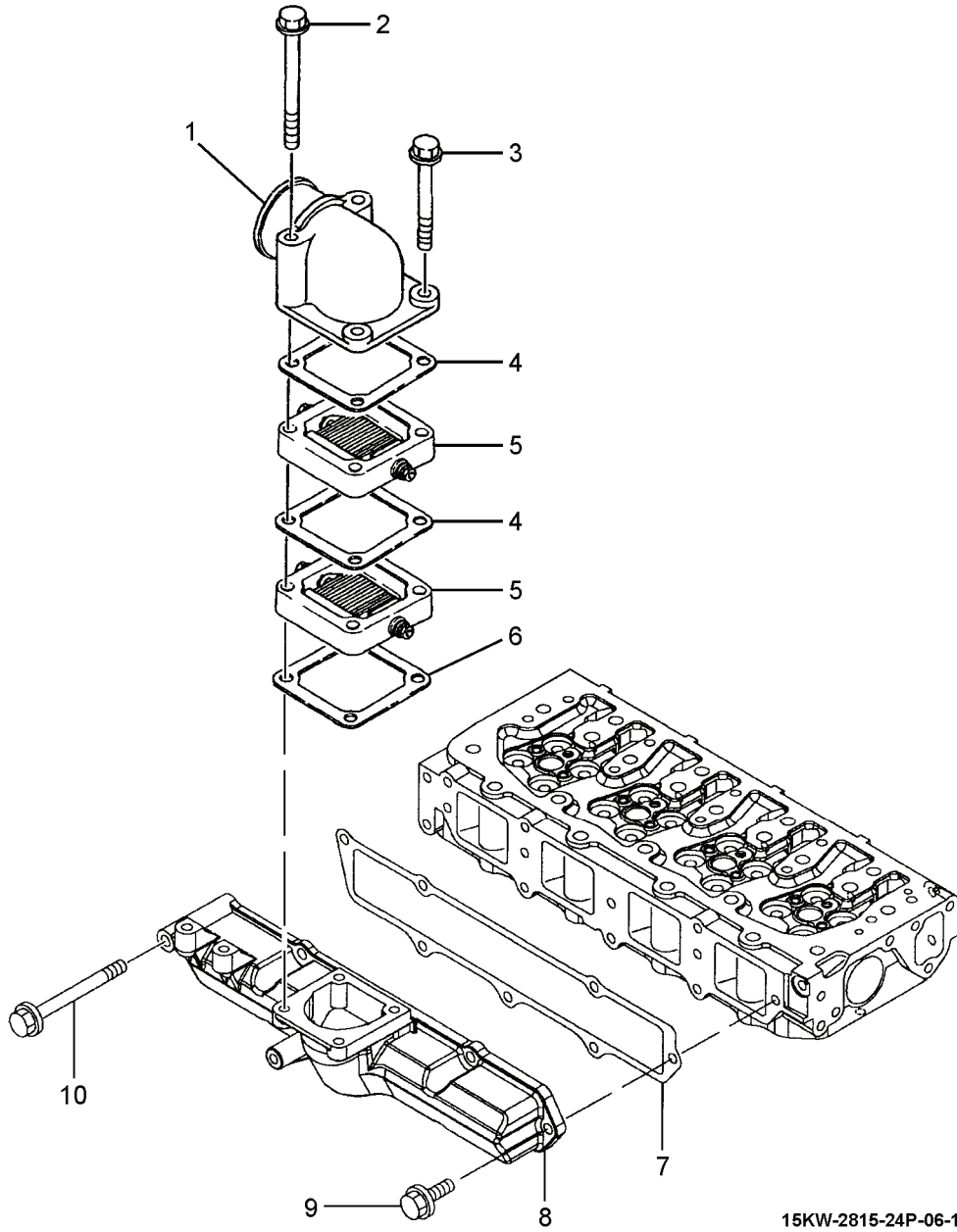
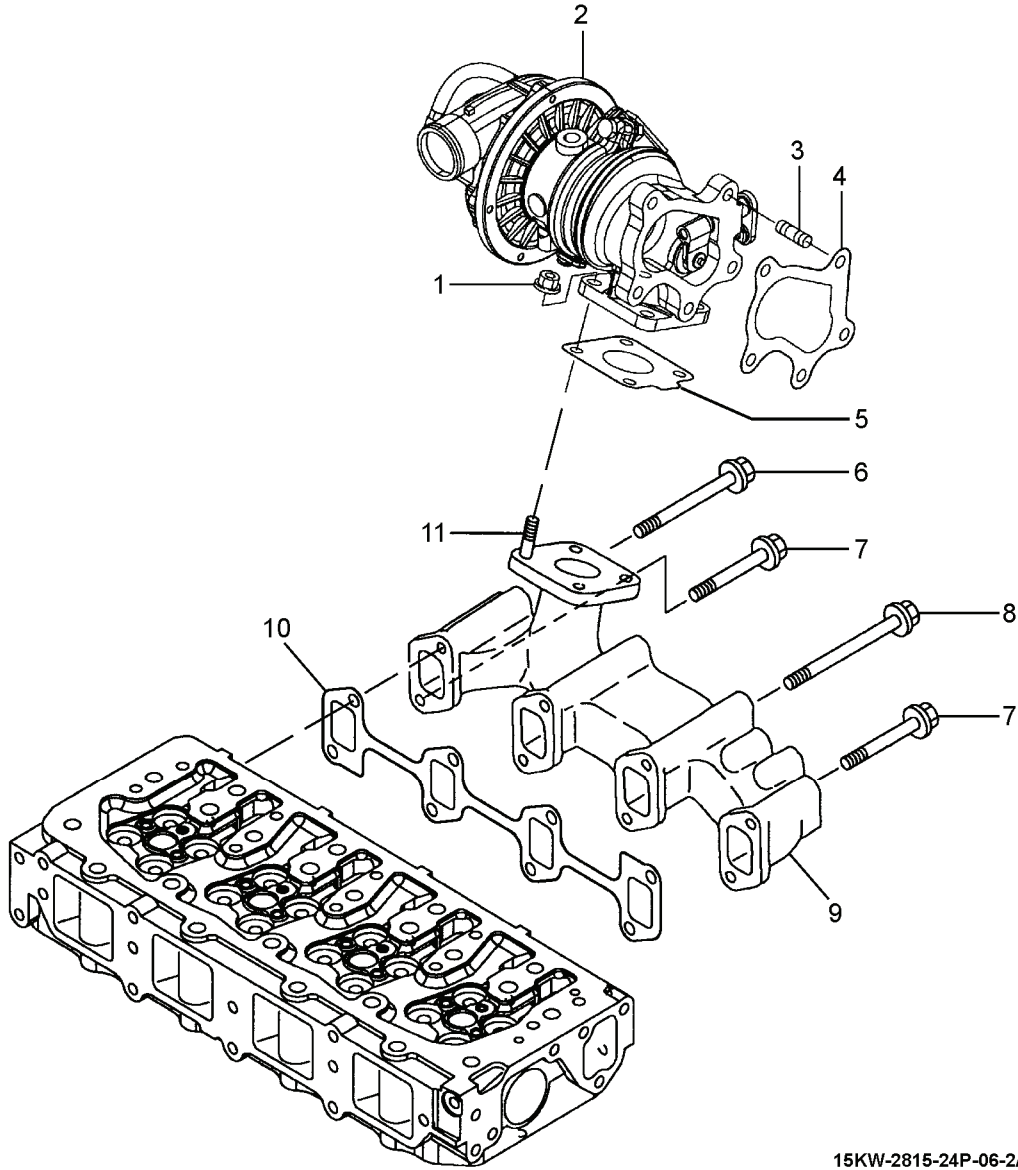

Figure 20. Intake Manifold.

(1) ITEM NO.	(2) SMR CODE	(3) NSN	(4) CAGEC	(5) PART NUMBER	(6) DESCRIPTION AND USABLE ON CODE (UOC)	(7) QTY
GROUP 05 EXHAUST SYSTEM						
FIG. 20. INTAKE MANIFOLD						
1	XBFZZ		0AK42	171340-77520	ADAPTER, INTAKE MANIFOLD, DIESEL	1
2	PAFZZ	5306-01-546-3581	0AK42	26106-081002	BOLT, MACHINE	2
3	PAFZZ	5306-01-547-0515	0AK42	26106-080602	BOLT, MACHINE	2
4	PAFZZ	5330-01-477-4043	0AK42	129100-77510	GASKET	2
5	PAFZZ	2990-01-546-4578	0AK42	129100-77500	AIR DUCT, ENGINE	2
6	PAFZZ	5330-01-419-5480	0AK42	129150-77511	GASKET	1
7	PAFZZ	5330-01-546-4259	0AK42	129508-12110	GASKET, MANIFOLD	1
8	XBFZZ		0AK42	129508-12120	MANIFOLD, INTAKE	1
9	PAFZZ	5306-01-546-8913	0AK42	26106-080202	BOLT, MACHINE	6
10	PAFZZ	5306-01-546-8565	0AK42	26106-080802	BOLT, MACHINE	1
END OF FIGURE						

FIELD AND SUSTAINMENT LEVEL
DIESEL ENGINE, 4TNV84T-DFM
NSN 2815-01-538-4237
TURBOCHARGER ASSEMBLY
REPAIR PARTS LIST



15KW-2815-24P-06-2A

Figure 21. Turbocharger Assembly.

(1) ITEM NO.	(2) SMR CODE	(3) NSN	(4) CAGEC	(5) PART NUMBER	(6) DESCRIPTION AND USABLE ON CODE (UOC)	(7) QTY
GROUP 0501 TURBINE ASSEMBLY						
FIG. 21. TURBOCHARGER ASSEMBLY						
1	PAFZZ	5310-01-546-8927	0AK42	26306-080002	NUT, PLAIN, HEXAGON HEAD	5
2	PAFHH	2950-01-537-9970	0AK42	129508-18010	TURBOSUPERCHARGER, ENGINE	1
3	PAFZZ	5307-01-546-8878	0AK42	129418-18320	STUD, THREADED	5
4	PAFZZ	5330-01-546-8879	0AK42	129508-18090	GASKET, TURBOCHARGER	1
5	PAFZZ	5330-01-546-6855	0AK42	129508-18080	GASKET	1
6	PAFZZ	5306-01-546-4268	0AK42	119802-13670	BOLT, MACHINE	1
7	PAFZZ	5306-01-547-0056	0AK42	119802-13650	BOLT, MACHINE	3
8	PAFZZ	5306-01-546-3568	0AK42	129693-44310	BOLT, MACHINE	4
9	XBFZZ		0AK42	129403-13120	MANIFOLD, EXHAUST	1
10	PAFZZ	5330-01-455-4061	0AK42	129550-13110	GASKET	1
11	PAFZZ	5306-01-546-8540	0AK42	119131-18320	BOLT, MACHINE	4
END OF FIGURE						

**FIELD AND SUSTAINMENT LEVEL
DIESEL ENGINE, 4TNV84T-DFM
NSN 2815-01-538-4237
STARTER MOTOR ASSEMBLY
REPAIR PARTS LIST**

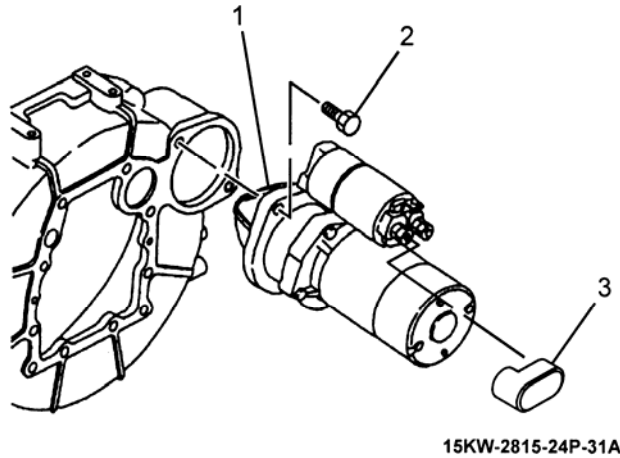
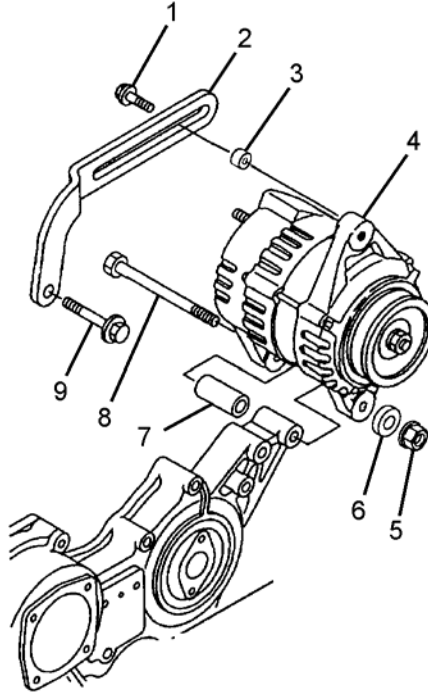

Figure 22. Starter Motor Assembly.

(1) ITEM NO.	(2) SMR CODE	(3) NSN	(4) CAGEC	(5) PART NUMBER	(6) DESCRIPTION AND USABLE ON CODE (UOC)	(7) QTY
					GROUP 0601 STARTER MOTOR ASSEMBLY	
					FIG. 22. STARTER MOTOR ASSEMBLY	
1	PAOZZ	2920-01-546-8025	0AK42	129612-77011	STARTING MOTOR	1
2	PAOZZ	5306-01-546-4272	0AK42	26116-120252	BOLT, MACHINE	2
3	PAOZZ	5940-01-546-8988	0AK42	121254-77810	COVER, TERMINAL	1
					END OF FIGURE	

**FIELD AND SUSTAINMENT LEVEL
DIESEL ENGINE, 4TNV84T-DFM
NSN 2815-01-538-4237
GENERATOR
REPAIR PARTS LIST**



15KW-2815-24P-30

Figure 23. Generator.

(1) ITEM NO.	(2) SMR CODE	(3) NSN	(4) CAGEC	(5) PART NUMBER	(6) DESCRIPTION AND USABLE ON CODE (UOC)	(7) QTY
					GROUP 0602 GENERATOR	
					FIG. 23. GENERATOR	
1	PAOZZ	5306-01-546-3532	0AK42	119810-77340	BOLT, MACHINE	1
2	XBOZZ		0AK42	129646-77330	BRACKET, BELT ADJUSTER.....	1
3	XBOZZ		0AK42	119940-77270	SPACER.....	1
4	PAOZZ	6115-01-546-2792	0AK42	129900-77240	GENERATOR, ENGINE ACCESSORY	1
5	PAOZZ	5310-01-547-0460	0AK42	26306-100002	NUT, PLAIN, HEXAGON HEAD.....	1
6	PAOZZ	5310-01-546-8889	0AK42	22137-100000	WASHER, FLAT.....	1
7	XBOZZ		0AK42	129470-77340	SPACER.....	1
8	PAOZZ	5306-01-546-8846	0AK42	26116-101202	BOLT, MACHINE	1
9	PAOZZ	5306-01-546-4273	0AK42	26014-080252	BOLT, MACHINE.....	1
					END OF FIGURE	

**FIELD AND SUSTAINMENT LEVEL
DIESEL ENGINE, 4TNV84T-DFM
NSN 2815-01-538-4237
SPECIAL TOOLS LIST**

NOT APPLICABLE.

**FIELD AND SUSTAINMENT LEVEL
DIESEL ENGINE, 4TNV84T-DFM
NSN 2815-01-538-4237
BULK MATERIAL LIST**

NOT APPLICABLE.

**FIELD AND SUSTAINMENT LEVEL
DIESEL ENGINE, 4TNV84T-DFM
NSN 2815-01-538-4237
NATIONAL STOCK NUMBER INDEX**

STOCK NUMBER	FIG ITEM	STOCK NUMBER	FIG ITEM
5305-01-158-0835	10 5	5340-01-546-3539	14 11
	11 5	4820-01-546-3548	4 16
	18 4	5307-01-546-3559	10 3
	19 10	5306-01-546-3568	21 8
4730-01-322-4956	19 8	5310-01-546-3576	7 10
5340-01-323-7844	11 25	4720-01-546-3578	4 18
	11 29	5306-01-546-3581	20 2
	14 8	3040-01-546-4092	7 11
5330-01-326-2669	19 9	4730-01-546-4242	11 12
5305-01-388-6229	10 8	4820-01-546-4246	4 6
	17 1	4730-01-546-4247	11 21
5306-01-388-6230	11 3		4 13
	19 6	4710-01-546-4250	14 13
5310-01-388-8826	17 11	4710-01-546-4254	14 10
5330-01-419-5480	20 6	5331-01-546-4255	10 6
5306-01-431-7461	16 3	5340-01-546-4256	18 8
	19 1	5330-01-546-4259	20 7
5330-01-454-4380	10 11	5331-01-546-4260	5 4
5330-01-454-4384	19 14	5306-01-546-4263	3 2
3120-01-454-6117	2 7	5306-01-546-4266	7 8
5330-01-454-6389	11 13	5306-01-546-4268	21 6
5330-01-455-4061	21 10	5306-01-546-4269	2 9
3020-01-455-4443	7 4	5306-01-546-4272	22 2
3120-01-455-5082	6 7	5306-01-546-4273	23 9
5315-01-465-9931	7 6	5306-01-546-4275	6 8
	9 3	2815-01-546-4309	7 5
5305-01-477-3508	10 9	2815-01-546-4327	4 12
5330-01-477-4043	20 4	2590-01-546-4329	18 7
5365-01-526-7332	11 23	2815-01-546-4567	4 8
5306-01-529-1138	17 17	5315-01-546-4572	4 9
2950-01-537-9970	21 2	2990-01-546-4578	20 5
2815-01-537-9999	9 1	2920-01-546-4582	7 1
2910-01-538-0115	15 1	2815-01-546-4587	4 19
2815-01-538-0771	4 2	4730-01-546-4701	16 16
3020-01-538-0777	7 13	2815-01-546-4717	6 3
2815-01-538-0835	6 5	2815-01-546-4721	6 4
2815-01-538-0974	7 3	2910-01-546-4727	13 1
2815-01-538-0978	6 2	2940-01-546-5058	16 11
6115-01-546-2792	23 4	5330-01-546-6844	16 1
6685-01-546-3005	11 9	5330-01-546-6855	21 5
5306-01-546-3527	14 2	5340-01-546-6859	6 1
4710-01-546-3530	14 15	4720-01-546-6890	13 9
5306-01-546-3532	23 1	5330-01-546-7537	2 14
5330-01-546-3538	11 1	4730-01-546-7538	16 8
	16 13	5330-01-546-8883	14 4

<u>STOCK NUMBER</u>	<u>FIG ITEM</u>	<u>STOCK NUMBER</u>	<u>FIG ITEM</u>
5330-01-546-7545	16 20	4710-01-546-8886	14 3
2815-01-546-7688	7 2	5310-01-546-8889	23 6
4720-01-546-7874	14 9	4720-01-546-8893	11 27
2835-01-546-7876	17 5	5330-01-546-8895	11 31
2930-01-546-7913	12 1	5330-01-546-8898	11 11
2920-01-546-8025	22 1	5306-01-546-8899	19 2
5306-01-546-8037	13 3	5330-01-546-8902	4 11
5306-01-546-8037	15 4	4730-01-546-8903	11 22
2815-01-546-8047	6 3	5305-01-546-8908	18 1
4720-01-546-8050	13 5	5306-01-546-8910	12 2
5306-01-546-8052	11 6	5305-01-546-8911	4 5
2930-01-546-8053	16 9	5306-01-546-8913	15 3
4720-01-546-8124	11 30		16 21
5331-01-546-8126	18 6		20 9
5330-01-546-8128	4 20	5310-01-546-8916	3 6
2915-01-546-8222	14 1		3 10
2815-01-546-8227	19 7		4 4
3120-01-546-8480	2 8	5340-01-546-8917	11 26
5331-01-546-8510	10 1	5310-01-546-8918	3 13
5331-01-546-8517	5 11	5330-01-546-8924	5 5
3020-01-546-8538	18 3	5310-01-546-8927	10 2
5306-01-546-8540	21 11		21 1
5306-01-546-8565	20 10	5306-01-546-8929	4 1
5315-01-546-8568	3 5		7 7
	3 9	3120-01-546-8931	2 7
5305-01-546-8629	5 2	5331-01-546-8932	17 2
5306-01-546-8846	23 8	5365-01-546-8936	6 6
3120-01-546-8851	16 7	4730-01-546-8975	13 8
4720-01-546-8857	16 12		13 6
4730-01-546-8861	16 4	5940-01-546-8988	22 3
4730-01-546-8864	16 14	4730-01-546-9221	16 6
4720-01-546-8868	16 5	4710-01-546-9222	17 12
5330-01-546-8869	7 16	4730-01-546-9253	11 17
5305-01-546-8870	11 20	5306-01-546-9263	17 9
4810-01-546-8874	17 4	3120-01-546-9268	6 7
5310-01-546-8875	14 5	5310-01-546-9272	7 9
	17 8	5310-01-546-9316	17 14
	17 10	5355-01-546-9841	5 10
5315-01-546-8877	17 6	5365-01-546-9878	16 15
	9 5	5306-01-546-9886	17 13
5307-01-546-8878	21 3	5310-01-546-9888	9 7
5330-01-546-8879	21 4	5306-01-546-9891	9 8
5310-01-546-8881	16 10	5315-01-546-9902	19 3
	8 4		
	9 2		

<u>STOCK NUMBER</u>	<u>FIG ITEM</u>	<u>STOCK NUMBER</u>	<u>FIG ITEM</u>
5330-01-546-9903	14 16		
4710-01-546-9905	14 14		
4730-01-546-9935	14 6		
5306-01-546-9973	8 1		
2815-01-546-9997	4 15		
5306-01-547-0001	10 14		
5306-01-547-0056	21 7		
5306-01-547-0081	7 16		
5307-01-547-0090	3 3		
5315-01-547-0091	4 14		
5307-01-547-0405	16 18		
5360-01-547-0442	4 10		
5310-01-547-0460	23 5		
5330-01-547-0461	11 10		
5306-01-547-0465	2 13		
5331-01-547-0466	11 4		
5340-01-547-0471	14 12		
3120-01-547-0495	2 8		
5306-01-547-0515	11 15		
	20 3		
5331-01-547-0529	10 16		
5365-01-547-0544	7 14		
5365-01-547-0563	4 7		
5306-01-547-0595	3 7		
5330-01-547-0629	11 18		
5306-01-547-2404	19 5		
	3 11		
3020-01-547-4625	9 6		
3020-01-547-4629	9 4		
3020-01-547-4658	18 2		
3030-01-547-4661	12 5		
5305-14-469-7436	11 14		
	17 15		
5306-99-450-7012	8 3		
3120-99-549-3927	2 4		
5330-99-727-8075	11 8		

**FIELD AND SUSTAINMENT LEVEL
DIESEL ENGINE, 4TNV84T-DFM
NSN 2815-01-538-4237
PART NUMBER INDEX**

CAGEC	PART NUMBER	STOCK NUMBER	FIG.	ITEM
0AK42	105025-59560	4720-01-546-6890	13	9
56161	10502560	5305-01-158-0835	10	5
			11	5
			18	4
			19	10
0AK42	105425-01690	4730-01-322-4956	19	8
0AK42	119131-18320	5306-01-546-8540	21	11
0AK42	119305-59120	5340-01-547-0471	14	12
0AK42	119609-32040	5331-01-547-0529	10	16
0AK42	119620-01750		8	5
0AK42	119625-11880	2815-01-546-4587	4	19
0AK42	119717-11190	5365-01-547-0563	4	7
0AK42	119717-11340	5330-01-546-8902	4	11
0AK42	119717-11350	5330-01-546-8128	4	20
0AK42	119717-11800	2815-01-546-4327	4	12
0AK42	119802-01520		10	4
0AK42	119802-01560	5307-01-546-3559	10	3
0AK42	119802-03070		5	8
0AK42	119802-11870	4720-01-546-3578	4	18
0AK42	119802-13650	5306-01-547-0056	21	7
0AK42	119802-13670	5306-01-546-4268	21	6
0AK42	119802-21202	3020-01-547-4629	9	4
0AK42	119802-21660	3020-01-547-4625	9	6
0AK42	119802-25051		7	15
0AK42	119802-25070	5365-01-547-0544	7	14
0AK42	119802-25100	3020-01-538-0777	7	13
0AK42	119802-25901		7	12
0AK42	119802-32070		18	12
0AK42	119802-32100	5340-01-546-4256	18	8
0AK42	119802-32130	5305-01-546-8908	18	1
0AK42	119802-35110		16	19
0AK42	119802-49113	4730-01-546-9253	11	17
0AK42	119802-49730	5340-01-546-8917	11	26
0AK42	119802-55800	2910-01-546-4727	13	1
0AK42	119807-11770		5	9
0AK42	119810-77340	5306-01-546-3532	23	1
0AK42	119940-59130	3120-01-546-8851	16	7
0AK42	119940-77270		23	3
0AK42	121023-01550		10	7
0AK42	121111-21501	5306-01-546-9973	8	1
0AK42	121252-39150	5306-01-529-1138	17	17
0AK42	121450-42450	4730-01-546-4242	11	12
0AK42	121550-23200	5306-01-546-4275	6	8
0AK42	121850-21680	5306-01-546-9891	9	8
0AK42	121850-42410	5305-01-546-8870	11	20
0AK42	121850-51960	5331-01-546-8510	10	1
0AK42	123907-11601	5330-01-546-9903	14	16
0AK42	123907-11830	5305-01-546-8911	4	5
0AK42	123907-59540	5306-01-546-3527	14	2
0AK42	123907-59550	5330-01-546-8883	14	4
0AK42	123907-59560	4730-01-546-9935	14	6
0AK42	124060-01050		2	10
0AK42	124160-01751	2590-01-546-4329	18	7
0AK42	124160-01910		2	6
0AK42	124160-11360	5355-01-546-9841	5	10
0AK42	124160-39140	5306-01-546-9886	17	13
0AK42	124240-01871		18	5
0AK42	124395-49840	5330-01-546-3538	11	1
0AK42	124465-44950	5330-01-546-8898	11	11
0AK42	124550-77030	5940-01-546-8988	22	3
0AK42	124722-59050	5340-01-323-7844	11	29
			11	25

<u>CAGEC</u>	<u>PART NUMBER</u>	<u>STOCK NUMBER</u>	<u>FIG.</u>	<u>ITEM</u>
0AK42	124722-59050	5340-01-323-7844	14	8
0AK42	124766-59050	4730-01-546-8975	13	6
			13	8
0AK42	129001-01250		2	11
0AK42	129001-02930	3120-01-547-0495	2	8
0AK42	129001-32330		18	9
0AK42	129001-91841	5306-01-547-0001	10	14
0AK42	129004-01190		2	12
0AK42	129004-22500	2815-01-546-4717	6	3
0AK42	129004-22950	2815-01-546-8047	6	3
0AK42	129004-42040		11	2
0AK42	129004-49610		11	24
0AK42	129004-49620		11	28
0AK42	129004-49711	4720-01-546-8893	11	27
0AK42	129004-49721	4720-01-546-8124	11	30
0AK42	129004-55610		13	2
0AK42	129005-59830		17	7
0AK42	129006-03120		5	3
0AK42	129006-35100		16	17
0AK42	129006-44480	4730-01-546-4701	16	16
0AK42	129100-01580	5315-01-546-9902	19	3
			8	4
			9	2
0AK42	129100-01640		19	13
0AK42	129100-23910	5365-01-546-8936	6	6
0AK42	129100-42051	5330-01-547-0629	11	18
0AK42	129100-42121		11	19
0AK42	129100-77500	2990-01-546-4578	20	5
S4163	129100-77510	5330-01-477-4043	20	4
0AK42	129103-49301	4730-01-546-8861	16	4
0AK42	129110-44740	2930-01-546-7913	12	1
0AK42	129120-01780	5330-01-454-4384	19	14
0AK42	129150-01200	5306-01-547-0465	2	13
0AK42	129150-02020	5306-01-546-4269	2	9
0AK42	129150-02450	2815-01-546-4309	7	5
0AK42	129150-02870	3120-01-546-8480	2	8
0AK42	129150-02930	3120-01-454-6117	2	7
0AK42	129150-02940	3120-01-546-8931	2	7
0AK42	129150-03070		5	6
0AK42	129150-03090		5	12
0AK42	129150-11230	5315-01-546-8568	3	9
			3	5
0AK42	129150-11750	5310-01-546-8916	3	6
			3	10
			4	4
0AK42	129150-14101	3020-01-455-4443	7	4
0AK42	129150-14200	2815-01-546-7688	7	2
0AK42	129150-14400	2920-01-546-4582	7	1
0AK42	129150-23600	3120-01-455-5082	6	7
0AK42	129150-23610	3120-01-546-9268	6	7
0AK42	129150-25301	5306-01-546-4266	7	8
0AK42	129150-35042	5330-01-546-6844	16	1
0AK42	129150-35091		16	2
0AK42	129150-35111	5330-01-546-7545	16	20
0AK42	129150-35152	2940-01-546-5058	16	11
0AK42	129150-49811	5330-01-547-0461	11	10
0AK42	129150-77511	5330-01-419-5480	20	6
0AK42	129155-42350		12	4
0AK42	129155-49801	6685-01-546-3005	11	9
0AK42	129202-22300	2815-01-546-4721	6	4
0AK42	129210-59110		13	7
0AK42	129210-59160		13	4
0AK42	129240-01500		10	10
0AK42	129350-49530		11	7
0AK42	129400-01730		19	4
0AK42	129403-13120		21	9

<u>CAGEC</u>	<u>PART NUMBER</u>	<u>STOCK NUMBER</u>	<u>FIG.</u>	<u>ITEM</u>
0AK42	129417-33110	5310-01-546-8881	16	10
0AK42	129417-35150	5307-01-547-0405	16	18
0AK42	129418-18320	5307-01-546-8878	21	3
0AK42	129418-32320		18	10
0AK42	129470-77340		23	7
0AK42	129486-01670	5306-01-546-8899	19	2
0AK42	129486-42021	5330-01-546-8895	11	31
0AK42	129486-42140	5331-01-547-0466	11	4
0AK42	129489-01770	2815-01-546-8227	19	7
0AK42	129508-01330	5330-01-546-7537	2	14
0AK42	129508-03010		5	7
0AK42	129508-11100	2815-01-546-9997	4	15
0AK42	129508-11110	4820-01-546-3548	4	16
0AK42	129508-11130	5360-01-547-0442	4	10
0AK42	129508-11180	2815-01-546-4567	4	8
0AK42	129508-11241		3	1
0AK42	129508-11250		3	17
0AK42	129508-11260		3	14
0AK42	129508-11270		3	12
0AK42	129508-11280	5310-01-546-8918	3	13
0AK42	129508-11310	5330-01-546-8924	5	5
0AK42	129508-11350		5	1
0AK42	129508-11650		3	8
0AK42	129508-11660		3	4
0AK42	129508-11700		4	2
0AK42	129508-11800		4	3
0AK42	129508-11820	5315-01-546-4572	4	9
0AK42	129508-11840	4820-01-546-4246	4	6
0AK42	129508-11900		3	16
0AK42	129508-11920		3	15
0AK42	129508-12110	5330-01-546-4259	20	7
0AK42	129508-12120		20	8
0AK42	129508-14580	2815-01-538-0974	7	3
0AK42	129508-18010	2950-01-537-9970	21	2
0AK42	129508-18080	5330-01-546-6855	21	5
0AK42	129508-18090	5330-01-546-8879	21	4
0AK42	129508-21002	2815-01-537-9999	9	1
0AK42	129508-22080	2815-01-538-0978	6	2
0AK42	129508-32111	3020-01-546-8538	18	3
0AK42	129508-32120	3020-01-547-4658	18	2
0AK42	129508-33010	2930-01-546-8053	16	9
0AK42	129508-39450	4710-01-546-9222	17	12
0AK42	129508-39600		17	3
0AK42	129508-42000		11	16
0AK42	129508-49030	4720-01-546-8857	16	12
0AK42	129508-49040	4720-01-546-8868	16	5
0AK42	129508-51250		15	2
0AK42	129508-59510	4720-01-546-7874	14	9
0AK42	129508-59550	4710-01-546-8886	14	3
0AK42	129508-59570		14	7
0AK42	129508-59910	4710-01-546-4250	14	13
0AK42	129508-59920	4710-01-546-9905	14	14
0AK42	129508-59930	4710-01-546-3530	14	15
0AK42	129508-59940	4710-01-546-4254	14	10
0AK42	129550-13110	5330-01-455-4061	21	10
0AK42	129550-59120	5340-01-546-3539	14	11
0AK42	129553-39650	2835-01-546-7876	17	5
0AK42	129612-59520	4720-01-546-8050	13	5
0AK42	129612-77011	2920-01-546-8025	22	1
0AK42	129646-77330		23	2
0AK42	129649-21590		8	2
0AK42	129693-44310	5306-01-546-3568	21	8
0AK42	129792-39410	4810-01-546-8874	17	4
0AK42	129795-01800	5330-01-454-4380	10	11
0AK42	129795-01950		10	15
0AK42	129795-02411	3120-99-549-3927	2	4

CAGEC	PART NUMBER	STOCK NUMBER	FIG.	ITEM
0AK42	129795-21661	5310-01-546-9888	9	7
0AK42	129795-49551	5330-99-727-8075	11	8
0AK42	129900-32130		18	11
0AK42	129900-77240	6115-01-546-2792	23	4
0AK42	129907-11950	5306-01-547-0595	3	7
0AK42	129916-49740	4730-01-546-8903	11	22
0AK42	158552-51151	3040-01-546-4092	7	11
0AK42	171008-03990	4730-01-546-8864	16	14
0AK42	171051-01921		2	3
0AK42	171056-49120	5365-01-546-9878	16	15
0AK42	171340-77520		20	1
0AK42	171353-44760		12	3
0AK42	171420-01600		8	6
0AK42	22137-100000	5310-01-546-8889	23	6
0AK42	22190-080002	5310-01-546-8875	14	5
			17	10
			17	8
0AK42	22190-100002	5310-01-546-9316	17	14
0AK42	22190-140002		19	15
0AK42	22190-160002	5330-01-326-2669	19	9
0AK42	22190-220002		19	11
0AK42	22217-140000	5310-01-546-3576	7	10
0AK42	22252-000260	5340-01-546-6859	6	1
0AK42	22351-030010	5315-01-546-8877	17	6
			9	5
0AK42	22351-060012	5315-01-547-0091	4	14
0AK42	22512-070140	5315-01-465-9931	7	6
			9	3
0AK42	22857-500100	5305-01-546-8629	5	2
0AK42	23080-015000	4730-01-546-7538	16	8
			16	13
0AK42	23080-018000	4730-01-546-9221	16	6
0AK42	23414-080000	5330-01-454-6389	11	13
0AK42	23414-100000	5330-01-546-8869	17	16
0AK42	23857-030000	5306-01-546-9263	17	9
0AK42	23857-080000		19	16
0AK42	23876-010000	5365-01-526-7332	11	23
0AK42	23876-020000	4730-01-546-4247	11	21
			4	13
0AK42	23876-030000		10	13
0AK42	23876-040000		10	12
0AK42	24311-000120	5331-01-546-8517	5	11
0AK42	24311-000320	5331-01-546-8126	18	6
0AK42	24314-000160	5331-01-546-8932	17	2
0AK42	24341-000240	5331-01-546-4255	10	6
0AK42	24341-000400	5331-01-546-4260	5	4
0AK42	25132-003800	3030-01-547-4661	12	5
0AK42	26014-080252	5306-01-546-4273	23	9
0AK42	26106-060162	5305-01-388-6229	10	8
			17	1
0AK42	26106-060402	5306-01-546-8910	12	2
S4163	26106-080122	5305-14-469-7436	11	14
			17	15
0AK42	26106-080142	5306-01-546-8929	4	1
			7	7
0AK42	26106-080202	5306-01-546-8913	15	3
			16	21
			20	9
0AK42	26106-080222	5306-01-546-8052	11	6
0AK42	26106-080252	5306-01-547-2404	19	5
			3	11
0AK42	26106-080302	5306-01-546-8037	13	3
			15	4
0AK42	26106-080352	5306-01-431-7461	16	3
			19	1

<u>CAGEC</u>	<u>PART NUMBER</u>	<u>STOCK NUMBER</u>	<u>FIG.</u>	<u>ITEM</u>
0AK42	26106-080402	5306-01-547-0081	7	16
0AK42	26106-080452	5306-01-388-6230	11	3
			19	6
0AK42	26106-080502	5306-01-546-4263	3	2
0AK42	26106-080552	5305-01-477-3508	10	9
0AK42	26106-080602	5306-01-547-0515	11	15
			20	3
0AK42	26106-080802	5306-01-546-8565	20	10
0AK42	26106-081002	5306-01-546-3581	20	2
0AK42	26116-101202	5306-01-546-8846	23	8
0AK42	26116-120252	5306-01-546-4272	22	2
0AK42	26206-100252	5306-99-450-7012	8	3
0AK42	26206-100302		8	7
0AK42	26226-080352	5307-01-547-0090	3	3
0AK42	26306-080002	5310-01-546-8927	10	2
			21	1
0AK42	26306-100002	5310-01-547-0460	23	5
0AK42	26366-060002	5310-01-388-8826	17	11
0AK42	26776-140002	5310-01-546-9272	7	9
0AK42	27241-120000		2	5
0AK42	27241-300000		2	2
0AK42	27241-400000		4	17
0AK42	729402-23100	2815-01-538-0835	6	5
0AK42	729508-01560		2	1
0AK42	729508-51310	2910-01-538-0115	15	1
0AK42	729508-53100	2915-01-546-8222	14	1
30554	88-20260-32	5305-01-056-1501	19	19
30554	97-24115		19	18
00U12	BELFER1		19	20
00U12	BELFER2		19	17
00U12	BELFER3		19	12

**FIELD LEVEL
DIESEL ENGINE, 4TNV84T-DFM
NSN 2815-01-538-4237
EXPENDABLE AND DURABLE ITEMS LIST**

EXPENDABLE AND DURABLE ITEMS LIST**INTRODUCTION****Scope**

This work package lists expendable and durable items that you will need to operate and maintain the diesel engine. This list is for information only and is not authority to requisition the listed items. These items are authorized to you by CTA 50-970, Expendable/Durable Items (Except Medical, Class V Repair Parts, and Heraldic Items), or CTA 8-100, Army Medical Department Expendable/Durable Items. Even though MIL and Federal specifications are cited, commercial equivalents may be used as required.

Explanation of Columns in the Expendable/Durable Items List

Column (1) - Item Number. This number is assigned to the entry in the list and is referenced in the narrative instructions to identify the item (e.g., □Use crocus cloth (item 1, WP 0064 00)□).

Column (2) - Level. This column includes the lowest level of maintenance that requires the listed item (O = Unit, F = Direct Support, D = Depot).

Column (3) - National Stock Number (NSN). This is the NSN assigned to the item which you can use to requisition it.

Column (4) - Item Name, Description, Commercial and Government Entity Code (CAGEC), and Part Number (P/N). This column provides the other information you need to identify the item.

Column (5) - Unit of Issue (U/I). Indicates the physical measurement or count of an item as issued per the National Stock Number shown in column (3).

Table 1. Expendable and Durable Items List.

(1) ITEM NUMBER	(2) LEVEL	(3) NATIONAL STOCK NUMBER	(4) ITEM NAME, DESCRIPTION, CAGEC, AND PART NUMBER	(5) U/I
1	F	5350-00-221-0872	Cloth, abrasive, crocus (58536) A-A-1206	PG
2	F	5330-01-438-1861	Compound, gasket forming (11083) 8C-8422	TU
3	F	9150-00-250-0927	Jelly, petroleum (81348) VV-P-236	QT
4	F	9150-01-152-4117	Oil, lubricating, engine (81349) MIL-L-2104	QT
5	F	7920-00-205-3571	Rag, wiping, cotton and cotton synthetic, grade B (81348) DDD-R-0030	CN
6	F	6850-01-378-0679	Solvent, cleaning compound, breakthrough, 5 gallon can (OK209)	CN
7	F	9905-00-537-8954	Tag, marker, 50 each bundle (81349) MIL-T-12755	BD
8	F	7150-00-778-6383	Tape, pressure sensitive, 3 in. wide, green, 36 yard roll (52152) 471	RL

INDEX

<u>Subject</u>	<u>WP Sequence No.-Page No.</u>
A, B	
Battery Charging Alternator (24 Vdc)	
Adjustment.....	0010 00-4
V-Belt Deflection Limits (Table 1)	0010 00-5
V-Belt Tension Adjustment (Figure 2).....	0010 00-4
V-Belt Tension Check (Figure 3).....	0010 00-5
Description.....	0002 00-1
Inspection	0010 00-3
Installation	0010 00-3
Battery Charging Alternator (24 Vdc) (Figure 1)	0010 00-2
Location	0002 00-1
Removal	0010 00-2
Battery Charging Alternator (24 Vdc) (Figure 1)	0010 00-2
Repair	0010 00-3
Repair Parts List.....	0059 00-1
C, D	
Compression Test.....	0023 00-2
Compression Test Setup (Figure 1)	0023 00-3
Crankcase Assembly and Dipstick	
Description	
Dipstick.....	0002 00-1
Inspection	0029 00-4
Crankcase Assembly and Dipstick (Figure 1).....	0029 00-3
Installation	0029 00-4
Crankcase Assembly and Dipstick (Figure 1).....	0029 00-3
Location	
Dipstick.....	0002 00-1
Removal	0029 00-2
Crankcase Assembly and Dipstick (Figure 1).....	0029 00-3
Repair	0029 00-4
Repair Parts List	
Crankcase Assembly	0055 00-1
Lubricating Nozzle	0052 00-1
Cylinder Head Assembly	
Inspection	0024 00-3
Installation	0024 00-4
Cylinder Head Assembly (Figure 1).....	0024 00-2
Removal	0024 00-2
Cylinder Head Assembly (Figure 1).....	0024 00-2
Cylinder Head Bolts (Figure 2).....	0024 00-3
Repair	0024 00-3
Repair Parts List	
Cylinder Head Assembly.....	0040 00-1

INDEX - Continued

Subject WP Sequence No.-Page No.

E

Equipment Description and Data	
Equipment Characteristics, Capabilities, and Features	0002 00-1
Equipment Data	0002 00-5
Engine, Diesel, Equipment Data (Table 1)	0002 00-5
Location and Description of Major Components	0002 00-1
Engine, Diesel (Figure 1)	0002 00-2
Flywheel Assembly	0002 00-1
Fuel Filter	0002 00-1
Fuel Injection Pump Assembly	0002 00-1
Gear Case Assembly	0002 00-2
Battery Charging Alternator (24 Vdc)	0002 00-1
Oil Dipstick	0002 00-1
Oil Fill Cap	0002 00-2
Oil Filter	0002 00-1
Sensor Switches	0002 00-2
Starter Motor Assembly	0002 00-1
Turbocharger Assembly	0002 00-1
Water Pump Assembly	0002 00-2
Expendable and Durable Items List	0064 00-1

F

Fan, V-Pulley, and V-Belt	
Inspection	0011 00-2
Installation	0011 00-3
Fan, V-Pulley, and V-Belt (Figure 1)	0011 00-2
Removal	0011 00-2
Fan, V-Pulley, and V-Belt (Figure 1)	0011 00-2
Repair	0011 00-2
Repair Parts List	0048 00-1
Flywheel Assembly and Flywheel Housing	
Description	0002 00-1
Inspection	0030 00-3
Flywheel Assembly and Flywheel Housing (Figure 1)	0030 00-2
Installation	0030 00-3
Flywheel Assembly and Flywheel Housing (Figure 1)	0030 00-2
Location	0002 00-1
Removal	0030 00-2
Flywheel Assembly and Flywheel Housing (Figure 1)	0030 00-2
Repair	0030 00-3
Repair Parts List	
Flywheel Assembly and Flywheel Housing	0044 00-1
Rear Oil Seal	0055 00-1

INDEX - Continued

Subject WP Sequence No.-Page No.

F - Continued

Fuel Filter and Fuel Hoses

Description	0002 00-1
Inspection	0017 00-3
Installation	0017 00-3
Fuel Filter and Fuel Hoses (Figure 1)	0017 00-2
Location	0002 00-1
Removal	0017 00-2
Fuel Filter and Fuel Hoses (Figure 1)	0017 00-2
Repair	0017 00-3
Repair Parts List	0049 00-1

Fuel Injection Lines and Return Hose

Inspection	0020 00-4
Installation	0020 00-4
Fuel Injection Lines and Return Hose (Figure 1)	0020 00-3
Removal	0020 00-2
Fuel Injection Lines and Return Hose (Figure 1)	0020 00-3
Repair	0020 00-4
Repair Parts List	0050 00-1

Fuel Injection Pump Assembly

Description	0002 00-1
Inspection	0016 00-9
Installation	0016 00-9
Cover Plate (Figure 2)	0016 00-3
Fuel Injection Pump Assembly (Figure 5)	0016 00-6
Gear Puller (Figure 4)	0016 00-5
Timing Adjustment Example (Figure 9)	0016 00-10
Timing Index Number (Figure 8)	0016 00-9
Timing Index Sticker (Figure 10)	0016 00-10
Location	0002 00-1
Removal	0016 00-2
Cover Plate (Figure 2)	0016 00-3
Drive Gear Reference Marks (Figure 3)	0016 00-4
Fuel Injection Pump Assembly (Figure 5)	0016 00-6
Fuel Injection Pump Assembly Plunger Plug (Figure 1)	0016 00-2
Gear Puller (Figure 4)	0016 00-5
Timing Grid Sticker Location (Figure 7)	0016 00-8
Timing Index Number (Figure 8)	0016 00-9
Timing Mark Location (Figure 6)	0016 00-7
Repair	0016 00-9
Repair Parts List	
Fuel Injection Lines and Return Hose	0050 00-1
Gasket and Mounting Hardware	0046 00-1
Spacer	0038 00-1
Support Bracket	0051 00-1
Timing Gear	0043 00-1

INDEX - Continued

Subject WP Sequence No.-Page No.

F - Continued

Fuel Injectors	
Inspection	0022 00-3
Fuel Injector Nozzle Pressure Test.....	0022 00-3
Fuel Injector Test (Figure 2).....	0022 00-3
Fuel Injectors (Figure 1).....	0022 00-2
Injector Leak Test	0022 00-3
Spray Pattern Inspection.....	0022 00-4
Normal and Abnormal Spray Patterns (Figure 3).....	0022 00-4
Installation	0022 00-4
Fuel Injectors (Figure 1).....	0022 00-2
Removal	0022 00-2
Fuel Injectors (Figure 1).....	0022 00-2
Repair	0022 00-4
Repair Parts List	
Fuel Injector	0050 00-1
Fuel Injector Nozzle Protector.....	0040 00-1
Fuel Injector Nozzle Seal	0040 00-1

G, H

Gear Case Assembly	
Description.....	0002 00-2
Inspection	0014 00-3
Installation	0014 00-4
Gear Case Assembly (Figure 1)	0014 00-3
Location	0002 00-2
Removal	0014 00-2
Gear Case Assembly (Figure 1)	0014 00-3
Repair	0014 00-4
Repair Parts List.....	0046 00-1
General Information	
Common Tools and Test Equipment.....	0001 00-4
Consolidated Index of Army Publications and Blank Forms	0001 00-1
Corrosion Prevention and Control (CPC).....	0001 00-1
Destruction of Army Materiel to Prevent Enemy Use	0001 00-1
List of Abbreviations/Acronyms	0001 00-2
Maintenance, Forms, Records, and Reports.....	0001 00-1
Preparation for Storage or Shipment.....	0001 00-2
Quality of Material.....	0001 00-4
Repair Parts.....	0001 00-5
Reporting Equipment Improvement Recommendations (EIR)	0001 00-1
Safety, Care, and Handling	0001 00-4
Scope.....	0001 00-1

INDEX - Continued

Subject WP Sequence No.-Page No.

G, H - Continued

General Information - Continued
 Special Tools; Test, Measurement, and Diagnostic Equipment (TMDE); and
 Support Equipment0001 00-4
 Warranty Information0001 00-2
 General Maintenance
 Cleaning Instructions0009 00-2
 Castings, Forgings, and Machined Metal Parts0009 00-2
 Electrical Cable and Rubber Components0009 00-2
 Inspection Instructions0009 00-2
 Castings, Forgings, and Machined Metal Parts0009 00-3
 Drilled and Tapped (Threaded) Holes0009 00-3

 Repair Instructions0009 00-3
 Castings, Forgings, and Machined Metal Parts0009 00-3
 Scope0009 00-1
 Tagging Instructions0009 00-3
 Work Safety0009 00-1

I, J, K, L

Idle Gear Assembly
 Inspection0015 00-3
 Idle Gear Shaft and Bushing (Figure 2)0015 00-3
 Installation0015 00-4
 Idle Gear Assembly (Figure 1)0015 00-2
 Removal0015 00-2
 Idle Gear Assembly (Figure 1)0015 00-2
 Repair0015 00-3
 Repair Parts List0042 00-1

 Intake Manifold, Air Inlet Hose, and Air Heaters
 Inspection0026 00-4
 Installation0026 00-4
 Intake Manifold, Air Inlet Hose, and Air Heaters (Figure 1)0026 00-3
 Removal0026 00-2
 Intake Manifold, Air Inlet Hose, and Air Heaters (Figure 1)0026 00-3
 Repair0026 00-4
 Repair Parts List0056 00-1
 Testing0026 00-4
 Air Heater0026 00-4

M, N

Maintenance Allocation Chart0035 00-1
 Malfunction/Symptom Index, Troubleshooting0004 00-1

INDEX - Continued

Subject WP Sequence No.-Page No.

O

Oil Cooler Assembly and Oil Pressure Switch

 Description

 Oil Filter0002 00-1

 Inspection0018 00-4

 Installation0018 00-4

 Oil Cooler Assembly and Oil Pressure Switch (Figure 1)0018 00-3

 Location

 Oil Filter0002 00-1

 Removal0018 00-2

 Oil Cooler Assembly and Oil Pressure Switch (Figure 1)0018 00-3

 Repair0018 00-4

 Repair Parts List0052 00-1

Oil Pump Assembly Repair Parts List0054 00-1

P, Q

PMCS

 Introduction0007 00-1

 Lubrication Instructions0008 00-3

 Mandatory Replacement Parts0008 00-3

 PMCS, Including Lubrication Instructions0008 00-1

 Air Intake Diaphragm (1,500 Hours)0008 00-2

 Battery Charging Alternator (24 Vdc) (300 Hours)0008 00-2

 Engine (300 Hours)0008 00-1

 Engine (1,200 Hours)0008 00-2

 Engine Oil and Filter (First 50 Hours)0008 00-1

 Engine Oil and Filter (300 Hours)0008 00-1

 Fan V-Belts (First 50 Hours)0008 00-1

 Fan V-Belts (300 Hours)0008 00-2

 Fan V-Belts (1,500 Hours)0008 00-2

 Fuel Filter (300 Hours)0008 00-2

 Fuel Injection Nozzles (1,500 Hours)0008 00-2

 Fuel Injectors (3,000 Hours)0008 00-2

 Fuel System (300 Hours)0008 00-2

 Starter Cables (300 Hours)0008 00-1

 Valve Lash (1,500 Hours)0008 00-2

Preparation for Storage or Shipment0031 00-1

R

References0033 00-1

Rocker Arm Shaft Assembly Repair Parts List0039 00-1

INDEX - Continued

Subject

WP Sequence No.-Page No.

R - Continued

Repair Parts and Special Tools List

Bulk Material List	0061 00-1
Camshaft, Driving Gear, and Idle Gear Assemblies	0043 00-1
Connecting Rod and Piston Assembly	0042 00-1
Cooling System	0047 00-1
Crankcase Assembly	0055 00-1
Crankshaft Assembly	0045 00-1
Cylinder Block Assembly	0038 00-1
Cylinder Head Assembly	0040 00-1
Engine, Diesel, Turbocharged	0037 00-1
Fan Assembly	0048 00-1
Flywheel Assembly	0044 00-1
Fuel Injection Assembly	0051 00-1
Fuel Injection Valve System	0050 00-1
Fuel System	0049 00-1
Gear Case Assembly	0046 00-1
Generator	0059 00-1
Intake Manifold	0056 00-1
Introduction	0036 00-1
National Stock Number Index	0062 00-1
Oil Bypass Valve	0053 00-1
Oil Filter and Oil Cooler	0052 00-1
Oil Pump Assembly	0054 00-1
Part Number Index	0063 00-1
Rocker Arm Shaft Assembly	0039 00-1
Special Tools List	0060 00-1
Starter Motor Assembly	0058 00-1
Turbocharger Assembly	0057 00-1
Valve Cover Assembly	0041 00-1

S

Service Upon Receipt	0006 00-1
----------------------------	-----------

Starter Motor Assembly

Description	0002 00-1
Inspection	0019 00-2
Installation	0019 00-2
Starter Motor Assembly (Figure 1)	0019 00-2
Location	0002 00-1
Removal	0019 00-2
Starter Motor Assembly (Figure 1)	0019 00-2
Repair	0019 00-2
Repair Parts List	0058 00-1

INDEX - Continued

<u>Subject</u>	<u>WP Sequence No.-Page No.</u>
T, U	
Theory of Operation	
Air Inlet and Exhaust System	0003 00-5
Engine Cooling System	0003 00-3
Engine Overview	0003 00-1
Engine Starting and Battery Charging Components	0003 00-1
Fuel System.....	0003 00-2
General.....	0003 00-1
Lubrication System	0003 00-4
Thermostat, Cover, and Temperature Switch	
Inspection	0013 00-2
Installation	0013 00-3
Thermostat, Cover, and Temperature Switch (Figure 1)	0013 00-2
Removal	0013 00-2
Thermostat, Cover, and Temperature Switch (Figure 1)	0013 00-2
Repair	0013 00-2
Repair Parts List	0047 00-1
Torque Limits	0032 00-1
Troubleshooting	
Troubleshooting Index.....	0004 00-1
Troubleshooting Procedures	0005 00-1
Turbocharger Assembly and Exhaust Manifold	
Description.....	0002 00-1
Inspection	0028 00-4
Rotor Play	0028 00-4
Axial Play Measurement (Figure 2)	0028 00-4
Radial Play Measurement (Figure 3).....	0028 00-5
Turbocharger Assembly and Exhaust Manifold (Figure 1).....	0028 00-3
Waste Gate Actuator Leak Test.....	0028 00-6
Required Test Equipment (Table 1)	0028 00-6
Waste Gate Actuator Leak Test Setup (Figure 4).....	0028 00-6
Turbocharger Assembly and Exhaust Manifold (Figure 1).....	0028 00-3
Waste Gate Actuator Opening Pressure and Lift Test	0028 00-5
Installation	0028 00-7
Turbocharger Assembly and Exhaust Manifold (Figure 1)	0028 00-3
Location	0002 00-1
Removal	0028 00-2
Turbocharger Assembly and Exhaust Manifold (Figure 1)	0028 00-3
Repair	0028 00-6
Repair Parts List	0057 00-1

INDEX - Continued

Subject WP Sequence No.-Page No.

T, U - Continued

Turbocharger Oil Lines	
Inspection	0027 00-4
Installation	0027 00-4
Turbocharger Oil Lines (Figure 1)	0027 00-3
Removal	0027 00-2
Turbocharger Oil Lines (Figure 1)	0027 00-3
Repair	0027 00-4
Repair Parts List	0053 00-1

V

Valve Cover Assembly	
Description, Oil Fill Cap	0002 00-2
Assembly	0021 00-3
Valve Cover Assembly (Figure 1)	0021 00-2
Disassembly	0021 00-2
Valve Cover Assembly (Figure 1)	0021 00-2
Inspection	0021 00-3
Installation	0021 00-3
Valve Cover Assembly (Figure 1)	0021 00-2
Location, Oil Fill Cap	0002 00-2
Removal	0021 00-2
Valve Cover Assembly (Figure 1)	0021 00-2
Repair	0021 00-3
Repair Parts List	
Fuel Injection Line Seal	0050 00-1
Valve Cover Assembly	0041 00-1

Valve Lash	
Adjustment	0025 00-2
Lock Nut Tightening (Figure 4)	0025 00-3
No. 1 Cylinder at TDC (Figure 1)	0025 00-2
Valve Bridge Clearance (Figure 2)	0025 00-2
Clearance Gap (Figure 3)	0025 00-3

W, X, Y, Z

Water Pump Assembly	
Description	0002 00-2
Inspection	0012 00-3
Installation	0012 00-4
Water Pump Assembly (Figure 1)	0012 00-3
Location	0002 00-2
Removal	0012 00-2
Water Pump Assembly (Figure 1)	0012 00-3
Repair	0012 00-3
Repair Parts List	0047 00-1

RECOMMENDED CHANGES TO PUBLICATIONS AND BLANK FORMS For use of this form, see AR 25-30; the proponent agency is OAASA					Use Part II (reverse) for Repair Parts and Special Tool Lists (RPSTL) and Supply Catalogs/Supply Manuals (SC/SM).		DATE 30 August 2002		
TO: (Forward to proponent of publication or form) (Include ZIP Code) Commander, US Army CECOM LCMC ATTN: AMSEL-LC-LEO-E-ED Fort Monmouth, NJ 07703-5006					FROM: (Activity and location) (Include ZIP Code) Jane Q. Doe, SFC 1234 Any Street Anytown, AL 34565				
PART I - ALL PUBLICATIONS (EXCEPT RPSTL AND SC/SM) AND BLANK FORMS									
PUBLICATION/FORM NUMBER TM 11-1234-567-14					DATE 16 Sep 2001		TITLE Operator, Field and Sustainment Support Maintenance Manual for Radio, AN/ABC-123		
ITEM	PAGE	PARA-GRAPH	LINE	FIGURE NO.	TABLE	RECOMMENDED CHANGES AND REASON			
1	WP0005 PG 3		2			Test or Corrective Action column should identify a different WP number.			
TYPED NAME, GRADE OR TITLE Jane Q. Doe, SFC				TELEPHONE EXCHANGE/AUTOVON, PLUS EXTENSION 123-4567		SIGNATURE			

EXAMPLE

TO: (Forward to proponent of publication or form) (Include ZIP Code)				FROM: (Activity and location) (Include ZIP Code)			DATE	
PART II- REPAIR PARTS AND SPECIAL TOOL LISTS AND SUPPLY CATALOGS/SUPPLY MANUALS								
PUBLICATION/FORM NUMBER				DATE		TITLE		
PAGE NO.	COLM NO.	LINE NO.	NATIONAL STOCK NUMBER	REFERENCE NO.	FIGURE NO.	ITEM NO.	TOTAL NO. OF MAJOR ITEMS SUPPORTED	RECOMMENDED ACTION
EXAMPLE								
PART III - REMARKS (Any general remarks, recommendations, or suggestions for improvement of publications and blank forms. Additional space may be used if more space is needed.)								
EXAMPLE								
TYPED NAME, GRADE OR TITLE			TELEPHONE EXCHANGE/AUTOVON, PLUS EXTENSION			SIGNATURE		

RECOMMENDED CHANGES TO PUBLICATIONS AND BLANK FORMS For use of this form, see AR 25-30; the proponent agency is OAASA					Use Part II (reverse) for Repair Parts and Special Tool Lists (RPSTL) and Supply Catalogs/Supply Manuals (SC/SM).		DATE
TO: (Forward to proponent of publication or form) (Include ZIP Code)					FROM: (Activity and location) (Include ZIP Code)		
PART I - ALL PUBLICATIONS (EXCEPT RPSTL AND SC/SM) AND BLANK FORMS							
PUBLICATION/FORM NUMBER					DATE		TITLE
ITEM	PAGE	PARA- GRAPH	LINE	FIGURE NO.	TABLE	RECOMMENDED CHANGES AND REASON	
TYPED NAME, GRADE OR TITLE				TELEPHONE EXCHANGE/AUTOVON, PLUS EXTENSION		SIGNATURE	

TO: (Forward to proponent of publication or form) (Include ZIP Code)	FROM: (Activity and location) (Include ZIP Code)	DATE
---	---	-------------

PART II- REPAIR PARTS AND SPECIAL TOOL LISTS AND SUPPLY CATALOGS/SUPPLY MANUALS

PUBLICATION/FORM NUMBER			DATE		TITLE			
PAGE NO.	COLM NO.	LINE NO.	NATIONAL STOCK NUMBER	REFERENCE NO.	FIGURE NO.	ITEM NO.	TOTAL NO. OF MAJOR ITEMS SUPPORTED	RECOMMENDED ACTION

PART III - REMARKS (Any general remarks or recommendations, or suggestions for improvement of publications and blank forms. Additional blank sheets may be used if more space is needed.)

TYPED NAME, GRADE OR TITLE	TELEPHONE EXCHANGE/AUTOVON, PLUS EXTENSION	SIGNATURE
----------------------------	--	-----------

RECOMMENDED CHANGES TO PUBLICATIONS AND BLANK FORMS					Use Part II (<i>reverse</i>) for Repair Parts and Special Tool Lists (RPSTL) and Supply Catalogs/Supply Manuals (SC/SM).		DATE
For use of this form, see AR 25-30; the proponent agency is OAASA							
TO: (<i>Forward to proponent of publication or form</i>) (<i>Include ZIP Code</i>)					FROM: (<i>Activity and location</i>) (<i>Include ZIP Code</i>)		
PART I - ALL PUBLICATIONS (EXCEPT RPSTL AND SC/SM) AND BLANK FORMS							
PUBLICATION/FORM NUMBER					DATE		TITLE
ITEM	PAGE	PARA- GRAPH	LINE	FIGURE NO.	TABLE	RECOMMENDED CHANGES AND REASON	
TYPED NAME, GRADE OR TITLE				TELEPHONE EXCHANGE/AUTOVON, PLUS EXTENSION		SIGNATURE	

TO: <i>(Forward to proponent of publication or form) (Include ZIP Code)</i>	FROM: <i>(Activity and location) (Include ZIP Code)</i>	DATE
--	--	-------------

PART II- REPAIR PARTS AND SPECIAL TOOL LISTS AND SUPPLY CATALOGS/SUPPLY MANUALS

PUBLICATION/FORM NUMBER			DATE		TITLE			
PAGE NO.	COLM NO.	LINE NO.	NATIONAL STOCK NUMBER	REFERENCE NO.	FIGURE NO.	ITEM NO.	TOTAL NO. OF MAJOR ITEMS SUPPORTED	RECOMMENDED ACTION

PART III - REMARKS *(Any general remarks or recommendations, or suggestions for improvement of publications and blank forms. Additional blank sheets may be used if more space is needed.)*

TYPED NAME, GRADE OR TITLE	TELEPHONE EXCHANGE/AUTOVON, PLUS EXTENSION	SIGNATURE
----------------------------	--	-----------

RECOMMENDED CHANGES TO PUBLICATIONS AND BLANK FORMS					Use Part II (<i>reverse</i>) for Repair Parts and Special Tool Lists (RPSTL) and Supply Catalogs/Supply Manuals (SC/SM).		DATE
For use of this form, see AR 25-30; the proponent agency is OAASA							
TO: (<i>Forward to proponent of publication or form</i>) (<i>Include ZIP Code</i>)					FROM: (<i>Activity and location</i>) (<i>Include ZIP Code</i>)		
PART I - ALL PUBLICATIONS (EXCEPT RPSTL AND SC/SM) AND BLANK FORMS							
PUBLICATION/FORM NUMBER					DATE		TITLE
ITEM	PAGE	PARA- GRAPH	LINE	FIGURE NO.	TABLE	RECOMMENDED CHANGES AND REASON	
TYPED NAME, GRADE OR TITLE				TELEPHONE EXCHANGE/AUTOVON, PLUS EXTENSION		SIGNATURE	

TO: (Forward to proponent of publication or form) (Include ZIP Code)	FROM: (Activity and location) (Include ZIP Code)	DATE
---	---	-------------

PART II- REPAIR PARTS AND SPECIAL TOOL LISTS AND SUPPLY CATALOGS/SUPPLY MANUALS

PUBLICATION/FORM NUMBER			DATE	TITLE				
PAGE NO.	COLM NO.	LINE NO.	NATIONAL STOCK NUMBER	REFERENCE NO.	FIGURE NO.	ITEM NO.	TOTAL NO. OF MAJOR ITEMS SUPPORTED	RECOMMENDED ACTION

PART III - REMARKS (Any general remarks or recommendations, or suggestions for improvement of publications and blank forms. Additional blank sheets may be used if more space is needed.)

TYPED NAME, GRADE OR TITLE	TELEPHONE EXCHANGE/AUTOVON, PLUS EXTENSION	SIGNATURE
----------------------------	--	-----------

By Order of the Secretary of the Army:

Official:

JOYCE E. MORROW
*Administrative Assistant to the
Secretary of the Army*
0816304

GEORGE W. CASEY, JR
*General, United States Army
Chief of Staff*

By Order of the Secretary of the Air Force:

Official:

BRUCE CARLSON
General, USAF
Command, AFMC

T. MICHAEL MOSELEY
General, USAF
Chief of Staff

Army Distribution:

To be distributed in accordance with the initial distribution number (IDN) 256968 requirements for TM 9-2815-538-24&P.

THE METRIC SYSTEM AND EQUIVALENTS

LINEAR MEASURE

1 Centimeter = 10 Millimeters = 0.01 Meters = 0.3937 Inches
 1 Meter = 100 Centimeters = 1000 Millimeters = 39.37 Inches
 1 Kilometer = 1000 Meters = 0.621 Miles

SQUARE MEASURE

1 Sq Centimeter = 100 Sq Millimeters = 0.155 Sq Inches
 1 Sq Meter = 10,000 Sq Centimeters = 10.76 Sq Feet
 1 Sq Kilometer = 1,000,000 Sq Meters = 0.386 Sq Miles

WEIGHTS

1 Gram = 0.001 Kilograms = 1000 Milligrams = 0.035 Ounces
 1 Kilogram = 1000 Grams = 2.2 Lb
 1 Metric Ton = 1000 Kilograms = 1 Megagram = 1.1 Short Tons

CUBIC MEASURE

1 Cu Centimeter = 1000 Cu Millimeters = 0.06 Cu Inches
 1 Cu Meter = 1,000,000 Cu Centimeters = 35.31 Cu Feet

LIQUID MEASURE

1 Milliliter = 0.001 Liters = 0.0338 Fluid Ounces
 1 Liter = 1000 Milliliters = 33.82 Fluid Ounces

TEMPERATURE

$5/9 (^{\circ}\text{F} - 32) = ^{\circ}\text{C}$
 212^o Fahrenheit is equivalent to 100^o Celsius
 90^o Fahrenheit is equivalent to 32.2^o Celsius
 32^o Fahrenheit is equivalent to 0^o Celsius
 $9/5 \text{ C}^{\circ} + 32 = \text{F}^{\circ}$

APPROXIMATE CONVERSION FACTORS

<u>TO CHANGE</u>	<u>TO</u>	<u>MULTIPLY BY</u>
Inches	Centimeters	2.540
Feet	Meters	0.305
Yards	Meters	0.914
Miles	Kilometers	1.609
Square Inches	Square Centimeters	6.451
Square Feet	Square Meters	0.093
Square Yards	Square Meters	0.836
Square Miles	Square Kilometers	2.590
Acres	Square Hectometers	0.405
Cubic Feet	Cubic Meters	0.028
Cubic Yards	Cubic Meters	0.765
Fluid Ounces	Milliliters	29.573
Pints	Liters	0.473
Quarts	Liters	0.946
Gallons	Liters	3.785
Ounces	Grams	28.349
Pounds	Kilograms	0.454
Short Tons	Metric Tons	0.907
Pound-Feet	Newton-Meters	1.356
Pounds per Square Inch	Kilopascals	6.895
Miles per Gallon	Kilometers per Liter	0.425
Miles per Hour	Kilometers per Hour	1.609

<u>TO CHANGE</u>	<u>TO</u>	<u>MULTIPLY BY</u>
Centimeters	Inches	0.394
Meters	Feet	3.280
Meters	Yards	1.094
Kilometers	Miles	0.621
Square Centimeters	Square Inches	0.155
Square Meters	Square Feet	10.764
Square Meters	Square Yards	1.196
Square Kilometers	Square Miles	0.386
Square Hectometers	Acres	2.741
Cubic Meters	Cubic Feet	35.315
Cubic Meters	Cubic Yards	1.308
Milliliters	Fluid Ounces	0.034
Liters	Pints	2.113
Liters	Quarts	1.057
Liters	Gallons	0.264
Grams	Ounces	0.035
Kilograms	Pounds	2.205
Metric Tons	Short Tons	1.102
Newton-Meters	Pound-Feet	0.738
Kilopascals	Pounds per Square Inch	0.145
Kilometers per Liter	Miles per Gallon	2.354
Kilometers per Hour	Miles per Hour	0.621

